



Movement Synchrony in the post-pandemic work culture

100% DESIGN DEVELOPMENT PACKAGE

THESIS CAPSTONE 2022
MA Exhibition and Experience Design
Fashion Institute of Technology

Emily Yeung Schmidt

EMILY SCHMIDT

MA EXHIBITION & EXPERIENCE DESIGN

FASHION INSTITUTE OF TECHNOLOGY
School of Graduate Studies
272 West 27th St
New York, NY 10011



ST. ANN'S WAREHOUSE
45 Water Street
Brooklyn, NY 11201

CLIENT

GALLUP®

KEY PLAN

DISCLAIMER

This is an unpublished and proprietary work simultaneously protected under copyright, trade secret, and like laws of the United States and other countries. All rights reserved. These materials may not be reproduced, displayed, distributed, nor may the information therein be used or disclosed in whole or in part, without the express written permission of Emily Yeung Schmidt.

DRAWN BY: EMILY YEUNG SCHMIDT

SCALE: N/A

DATE: 12.9.2022

DRAWING TITLE:

DRAWING LIST

DRAWING NO:

EX001

EX0 GENERAL

- EX000 Cover Sheet
- EX001 Drawing List
- EX002 Symbol List

EX100 EXECUTIVE SUMMARY

- EX101 Thesis Statement
- EX102 Project Parameters
- EX103 Client
- EX104 Venue
- EX105 Audience
- EX106 Project & Exhibition Introduction
- EX107 Exhibition Goals
- EX108 Concept Diagram
- EX109 Bubble Floor Plan & Visitor's circulation
- EX110 Audience Emotional Journey

EX120 RENDERINGS

- EX121 Exhibition Axon
- EX122 Exhibition Entry
- EX123 Exhibition Introduction
- EX124 Entering Corridors
- EX125 Seeking Synchrony
- EX126 Creating Happy Hormones
- EX127 Take Your Course
- EX128 Take Your Course (cont.)
- EX129 Your Voice. My Voice.
- EX130 Your Voice. My Voice. (cont.)
- EX131 Pathways to Inspire
- EX132 Journey Together
- EX133 Journey Together
- EX134 Maze of Trust
- EX135 Maze of Trust (cont.)
- EX136 Summary: 6 Exhibition Areas
- EX137 Model Photo Survey

EX200 SCHEDULES & LISTS

- EX201 Graphic Schedule
- EX202 Graphic Specification List
- EX203 Material Schedule
- EX204 Lighting Schedule
- EX205 Artifact Schedule

EX300 PLANS & SECTIONS

- EX301 Code Floor Plan
- EX302 Dimension Floor Plan
- EX303 Detail Dimension Floor Plan
- EX304 Graphic Location Plan (Exterior)
- EX305 Graphic Location Plan (Interior)
- EX306 Material Plan
- EX307 Lighting Plan
- EX308 Artifact Plan
- EX320 Section Elevation 1
- EX321 Section Elevation 2
- EX322 Section Elevation 3

EX400 GRAPHIC SYSTEMS

- EX401 Visual Communication
- EX402 Mood Boards
- EX403 Concept Sketches
- EX404 Brand Color and Typeface
- EX405 Brand Identity
- EX406 Graphic Look and Feel
- EX407 Advertising Components 1
- EX408 Advertising Components 2
- EX409 Wayfinding Applications 1
- EX410 Wayfinding Applications 2
- EX411 Wayfinding Applications 3
- EX412 Collateral
- EX413 Digital Platform
- EX414 Graphic Family

EX500 DETAILING

- EX501 Introduction Graphic
- EX502 Area Graphic
- EX503 Content Graphic 1
- EX504 Content Graphic 2
- EX505 Content Graphic 3
- EX506 Content Graphic — Gobo Projectors
- EX507 Digital Graphic Touchscreens
- EX508 Acrylic Panels Installation Detail
- EX509 Projection Mapping Detail



ST. ANN'S WAREHOUSE
45 Water Street
Brooklyn, NY 11201

CLIENT
GALLUP®

KEY PLAN

DISCLAIMER
This is an unpublished and proprietary work simultaneously protected under copyright, trade secret, and like laws of the United States and other countries. All rights reserved. These materials may not be reproduced, displayed, distributed, nor may the information therein be used or disclosed in whole or in part, without the express written permission of Emily Yeung Schmidt.

DRAWN BY: EMILY YEUNG SCHMIDT

SCALE:

DATE: 12.9.2022

DRAWING TITLE:

SYMBOL LIST

DRAWING NO:

EX002

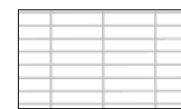

WOOD

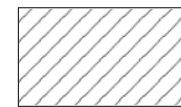

ACRYLIC PANEL

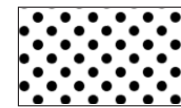

PRINTED ACOUSTIC PANEL

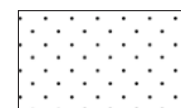

STRETCH FABRIC



TITLE REFERENCE

SCALE

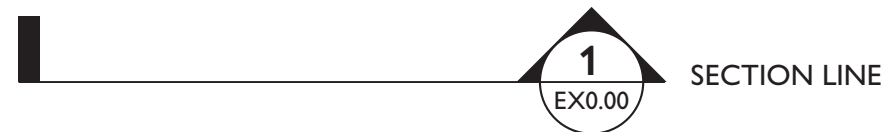

SECTION LINE

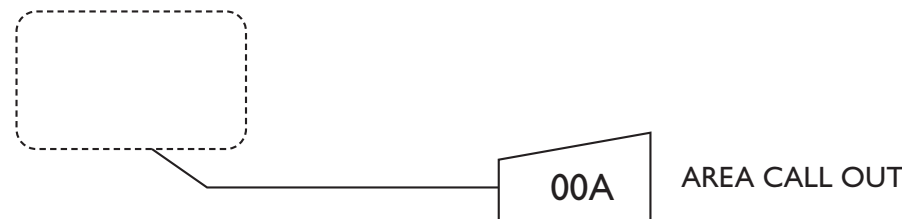

AREA CALL OUT

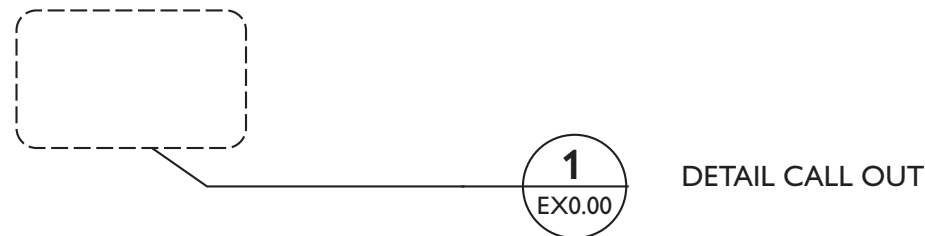

DETAIL CALL OUT

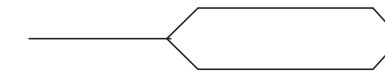

GRAPHIC REFERENCE

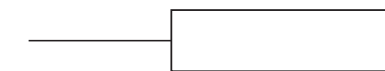

MATERIAL REFERENCE



ARTIFACT REFERENCE

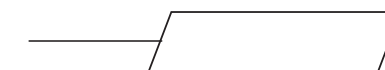

LIGHTING REFERENCE



MEDIA/AV REFERENCE



EX100 **EXECUTIVE SUMMARY**

THESIS STATEMENT

The COVID-19 pandemic may be the most challenging crisis many leaders in the work world have faced. It has **profoundly changed the landscape of our work culture and dramatically shifted how organizations operate, and leaders lead.** The new post-pandemic norm affects employees' social bonding, trust, productivity, loyalty, and collective mental health. **Movement Synchrony measures the mutual influence that occurs in interpersonal interaction.** It has been proposed to embody the quality of relationships. Exhibitions can provide a solution for leaders by incorporating the advantages of Movement Synchrony and putting forth new perspectives including flexibility and adaptability, and promoting naturally occurring happy hormones: Dopamine, Oxytocin, Serotonin, and Endorphin.

EMILY SCHMIDT
MA EXHIBITION & EXPERIENCE DESIGN

FASHION INSTITUTE OF TECHNOLOGY
School of Graduate Studies
272 West 27th St
New York, NY 10011



ST. ANN'S WAREHOUSE
45 Water Street
Brooklyn, NY 11201

CLIENT

GALLUP®

KEY PLAN

DISCLAIMER

This is an unpublished and proprietary work simultaneously protected under copyright, trade secret, and like laws of the United States and other countries. All rights reserved. These materials may not be reproduced, displayed, distributed, nor may the information therein be used or disclosed in whole or in part, without the express written permission of Emily Yeung Schmidt.

DRAWN BY: EMILY YEUNG SCHMIDT

SCALE: N/A

DATE: 12.9.2022

DRAWING TITLE:

THESIS STATEMENT

DRAWING NO:

EX101

PROJECT PARAMETERS

SUBJECT

Fostering Movement Synchrony in the post-pandemic work culture

CLIENT

Gallup®

VENUE

St. Ann's Warehouse, Dumbo, Brooklyn

AUDIENCE

Primary: Business Leaders

Secondary: Their Employees

Tertiary: General Public

EMILY SCHMIDT

MA EXHIBITION & EXPERIENCE DESIGN

FASHION INSTITUTE OF TECHNOLOGY
School of Graduate Studies
272 West 27th St
New York, NY 10011



ST. ANN'S WAREHOUSE
45 Water Street
Brooklyn, NY 11201

CLIENT

GALLUP®

KEY PLAN

DISCLAIMER

This is an unpublished and proprietary work simultaneously protected under copyright, trade secret, and like laws of the United States and other countries. All rights reserved. These materials may not be reproduced, displayed, distributed, nor may the information therein be used or disclosed in whole or in part, without the express written permission of Emily Yeung Schmidt.

DRAWN BY: EMILY YEUNG SCHMIDT

SCALE: N/A

DATE: 12.9.2022

DRAWING TITLE:

PROJECT PARAMETERS

DRAWING NO:

EX102

GALLUP®

ABOUT

Gallup is a global analytics and advice firm that helps leaders and organizations solve their most pressing problems. Gallup expertise: Employee Engagement, culture transformation, employee experience, leadership, organizational effectiveness.

MISSION

Since the unprecedented COVID-19 pandemic in 2020, Gallup conducts surveys and research on how the pandemic affects work life and workers' mental well-being globally. **To better understand the employee experience during COVID-19, Gallup has tracked the extent to which employees see their employers using three of the most effective tools** they have at their disposal to support their employees: **communication, concern for employees' wellbeing, and creating a climate of trust.** By implementing new concepts and integrating up-to-date interactive technologies, **this exhibition enables Gallup to create a new vision and gain new audience.**

EMILY SCHMIDT
MA EXHIBITION & EXPERIENCE DESIGN

FASHION INSTITUTE OF TECHNOLOGY
School of Graduate Studies
272 West 27th St
New York, NY 10011

in-sync

ST. ANN'S WAREHOUSE
45 Water Street
Brooklyn, NY 11201

CLIENT
GALLUP®

KEY PLAN

DISCLAIMER
This is an unpublished and proprietary work simultaneously protected under copyright, trade secret, and like laws of the United States and other countries. All rights reserved. These materials may not be reproduced, displayed, distributed, nor may the information therein be used or disclosed in whole or in part, without the express written permission of Emily Yeung Schmidt.

DRAWN BY: EMILY YEUNG SCHMIDT

SCALE: N/A

DATE: 12.9.2022

DRAWING TITLE:

CLIENT

DRAWING NO:

EX103

VENUE

ST. ANN'S WAREHOUSE | 45 WATER STREET, DUMBO, BROOKLYN

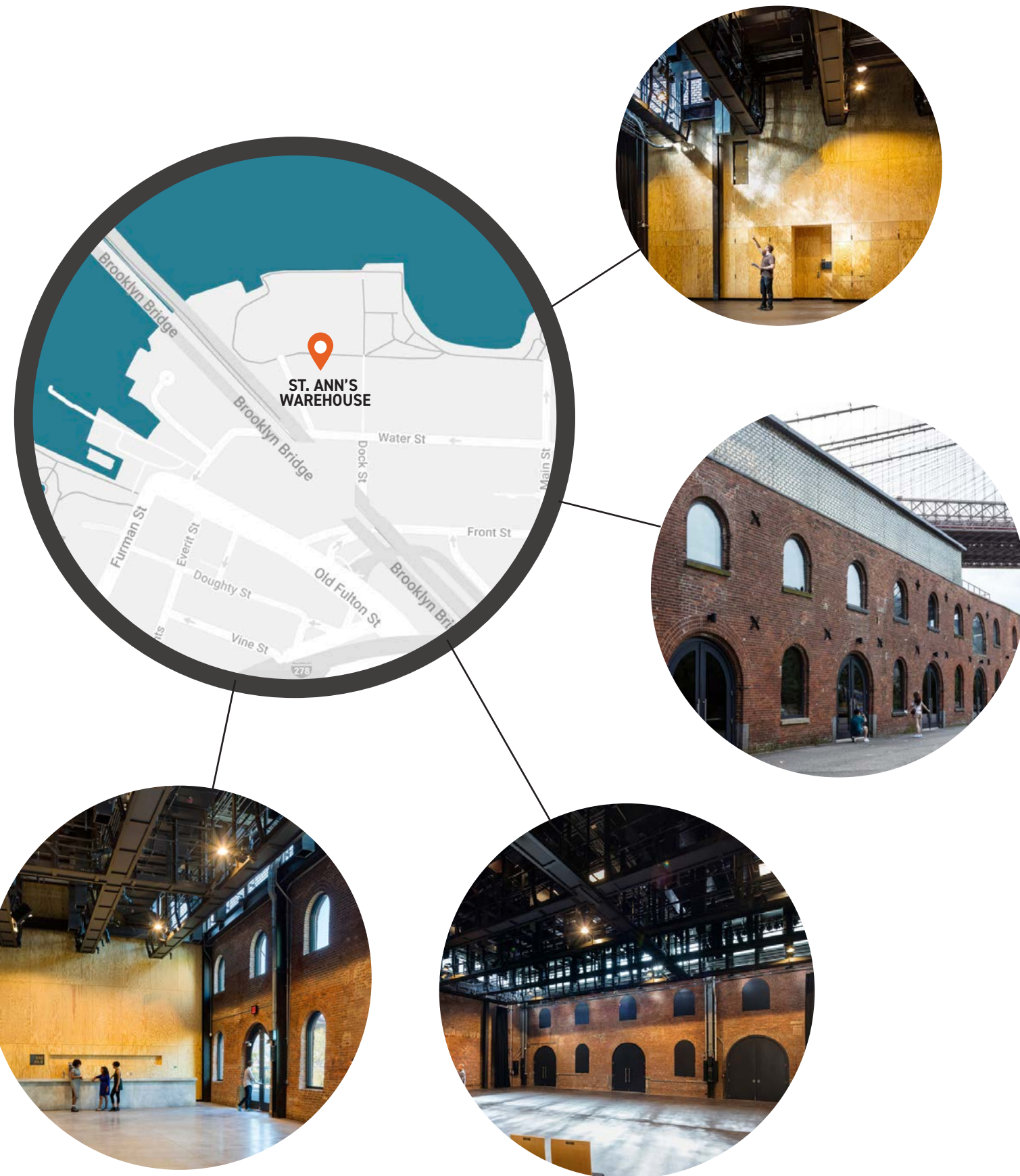

With a dramatic view of the Brooklyn Bridge, St. Ann's Warehouse is equally appropriate for theater, community events, exhibitions, and major concert presentations.

St. Ann's Warehouse has become one of New York City's most important and compelling live performance destinations. Formerly an old Tobacco Warehouse, the roofless 19th-century building has been transformed into a spectacular 21st-century theater and event space, rising in its majestic location along the East River waterfront.

The location is an ideal venue for the following reasons:

- Near the financial districts in downtown Manhattan
- Convenient location by subways, cars, or walk over from Brooklyn Bridge
- Perfect surroundings — parks, waterfront, restaurants and historic bridges
- Flexible floor plan

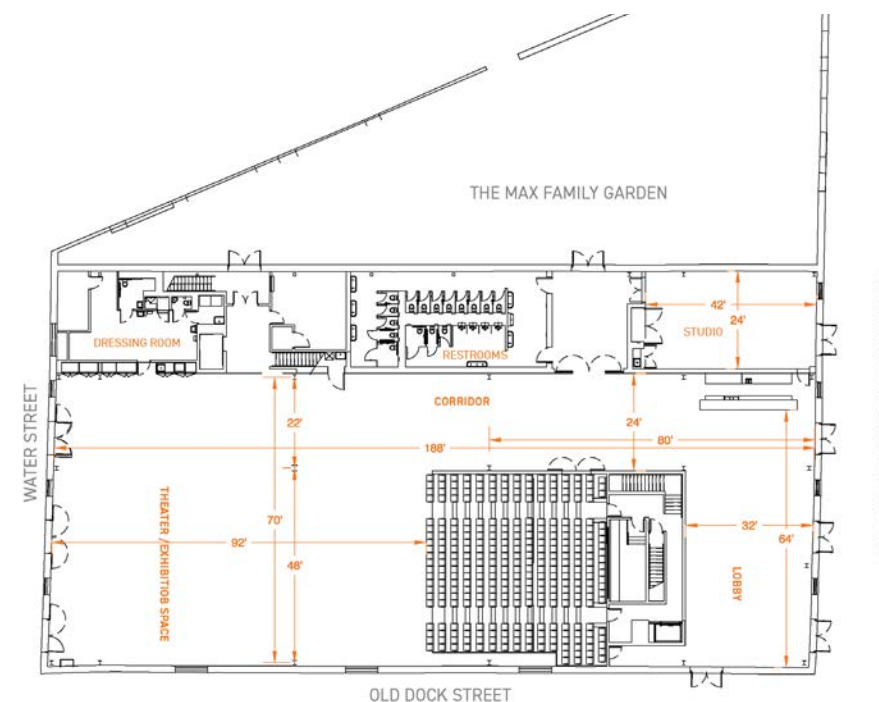

EMILY SCHMIDT

MA EXHIBITION & EXPERIENCE DESIGN

FASHION INSTITUTE OF TECHNOLOGY
School of Graduate Studies
272 West 27th St
New York, NY 10011



ST. ANN'S WAREHOUSE
45 Water Street
Brooklyn, NY 11201

CLIENT

GALLUP®

KEY PLAN

DISCLAIMER

This is an unpublished and proprietary work simultaneously protected under copyright, trade secret, and like laws of the United States and other countries. All rights reserved. These materials may not be reproduced, displayed, distributed, nor may the information therein be used or disclosed in whole or in part, without the express written permission of Emily Yeung Schmidt.

DRAWN BY: EMILY YEUNG SCHMIDT

SCALE: N/A

DATE: 12.9.2022

DRAWING TITLE:

VENUE

DRAWING NO:

EX104

AUDIENCE



PRIMARY: Business Leaders



SECONDARY: Their Employees

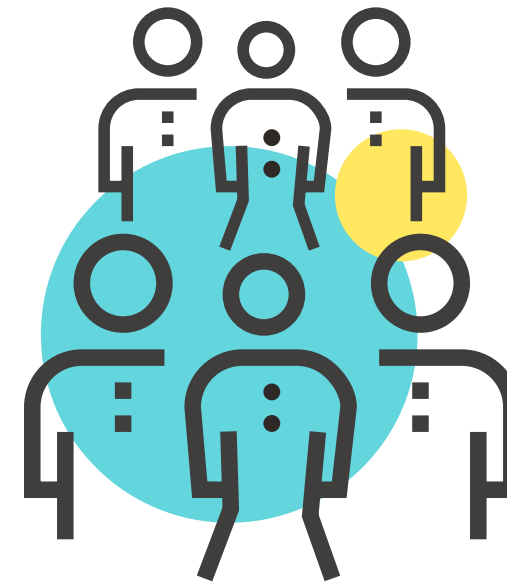

TERTIARY: General Public

EMILY SCHMIDT
MA EXHIBITION & EXPERIENCE DESIGN

FASHION INSTITUTE OF TECHNOLOGY
School of Graduate Studies
272 West 27th St
New York, NY 10011



ST. ANN'S WAREHOUSE
45 Water Street
Brooklyn, NY 11201

CLIENT
GALLUP®

KEY PLAN

DISCLAIMER
This is an unpublished and proprietary work simultaneously protected under copyright, trade secret, and like laws of the United States and other countries. All rights reserved. These materials may not be reproduced, displayed, distributed, nor may the information therein be used or disclosed in whole or in part, without the express written permission of Emily Yeung Schmidt.

DRAWN BY: EMILY YEUNG SCHMIDT

SCALE: N/A

DATE: 12.9.2022

DRAWING TITLE:
AUDIENCE

DRAWING NO:

EX105

PROJECT INTRODUCTION

The **COVID-19** pandemic has changed our work culture permanently; it affects employees' social bonding, trust, loyalty, productivity, and collective mental health. Leaders face close-call decisions between what's suitable for the organization's long-term success and creating a stable, positive work environment and climate for their employees. **My research focuses on finding a solution by incorporating Movement Synchrony and promoting naturally occurring happy hormones: Dopamine, Oxytocin, Serotonin, and Endorphin. This exhibition creates new perspectives on the current work climate in the post-pandemic culture.**

EXHIBITION INTRODUCTION

Sponsored by Gallup Inc., this project will be a month-long temporary exhibition at St. Ann's Warehouse, located in Dumbo, Brooklyn. **Throughout a series of six exhibition areas, visitors are introduced to both interactive digital and analog activities that foster Movement Synchrony and happy hormones in the current work climate. Visitors will reflect, engage, and learn by participating in the activities with the Power of Play which inspires trust, teamwork, inclusion, and adaptability as well as the importance of creating happiness in the workplace.**

EMILY SCHMIDT

MA EXHIBITION & EXPERIENCE DESIGN

FASHION INSTITUTE OF TECHNOLOGY
School of Graduate Studies
272 West 27th St
New York, NY 10011



ST. ANN'S WAREHOUSE
45 Water Street
Brooklyn, NY 11201

CLIENT

GALLUP®

KEY PLAN

DISCLAIMER

This is an unpublished and proprietary work simultaneously protected under copyright, trade secret, and like laws of the United States and other countries. All rights reserved. These materials may not be reproduced, displayed, distributed, nor may the information therein be used or disclosed in whole or in part, without the express written permission of Emily Yeung Schmidt.

DRAWN BY: EMILY YEUNG SCHMIDT

SCALE:

DATE: 12.9.2022

DRAWING TITLE:

**PROJECT & EXHIBITION
INTRODUCTION**

DRAWING NO:

EX106

EXHIBIT GOALS

PROJECT GOALS

The Exhibition will:

- **Incorporate Movement Synchrony into work culture**
- **Inspire leaders**
- Build strong teamwork
- Achieve high performance/productivity
- Reconnect employees
- Enhance employer's and employees' relationships
- **Promote four happy hormones — Dopamine, Oxytocin, Serotonin and Endorphin**
- **Reach new audience and promote Gallup**

EDUCATION GOALS

The audience will learn:

- How to build trust with one another
- How to embrace Movement Synchrony
- The importance of mental well-being at workplace
- Humanity at workplace
- **Neuroscience of happy hormones**
- **Happy work culture leads to a happy life**
- **Movement synchrony leads to job satisfaction**

EXPERIENCE GOALS

Visitors will experience:

- New ways of engaging and reconnecting
- Co-creation and inclusion
- **An immersive environment with digital interactive and analog activities**
- **The power of play**
- **New perspectives to embrace humanity at work**

EMILY SCHMIDT

MA EXHIBITION & EXPERIENCE DESIGN

FASHION INSTITUTE OF TECHNOLOGY
School of Graduate Studies
272 West 27th St
New York, NY 10011



ST. ANN'S WAREHOUSE
45 Water Street
Brooklyn, NY 11201

CLIENT

GALLUP®

KEY PLAN

DISCLAIMER

This is an unpublished and proprietary work simultaneously protected under copyright, trade secret, and like laws of the United States and other countries. All rights reserved. These materials may not be reproduced, displayed, distributed, nor may the information therein be used or disclosed in whole or in part, without the express written permission of Emily Yeung Schmidt.

DRAWN BY: EMILY YEUNG SCHMIDT

SCALE: N/A

DATE: 12.9.2022

DRAWING TITLE:

EXHIBIT GOALS

DRAWING NO:

EX107

CONCEPT DIAGRAM

REALITY NOW

Reflects post-pandemic work culture — hybrid and fully remote models. Lack of bonding and connection at workplace

- Social isolation
- Depression
- Disengaged
- Lack of loyalty
- Unproductive

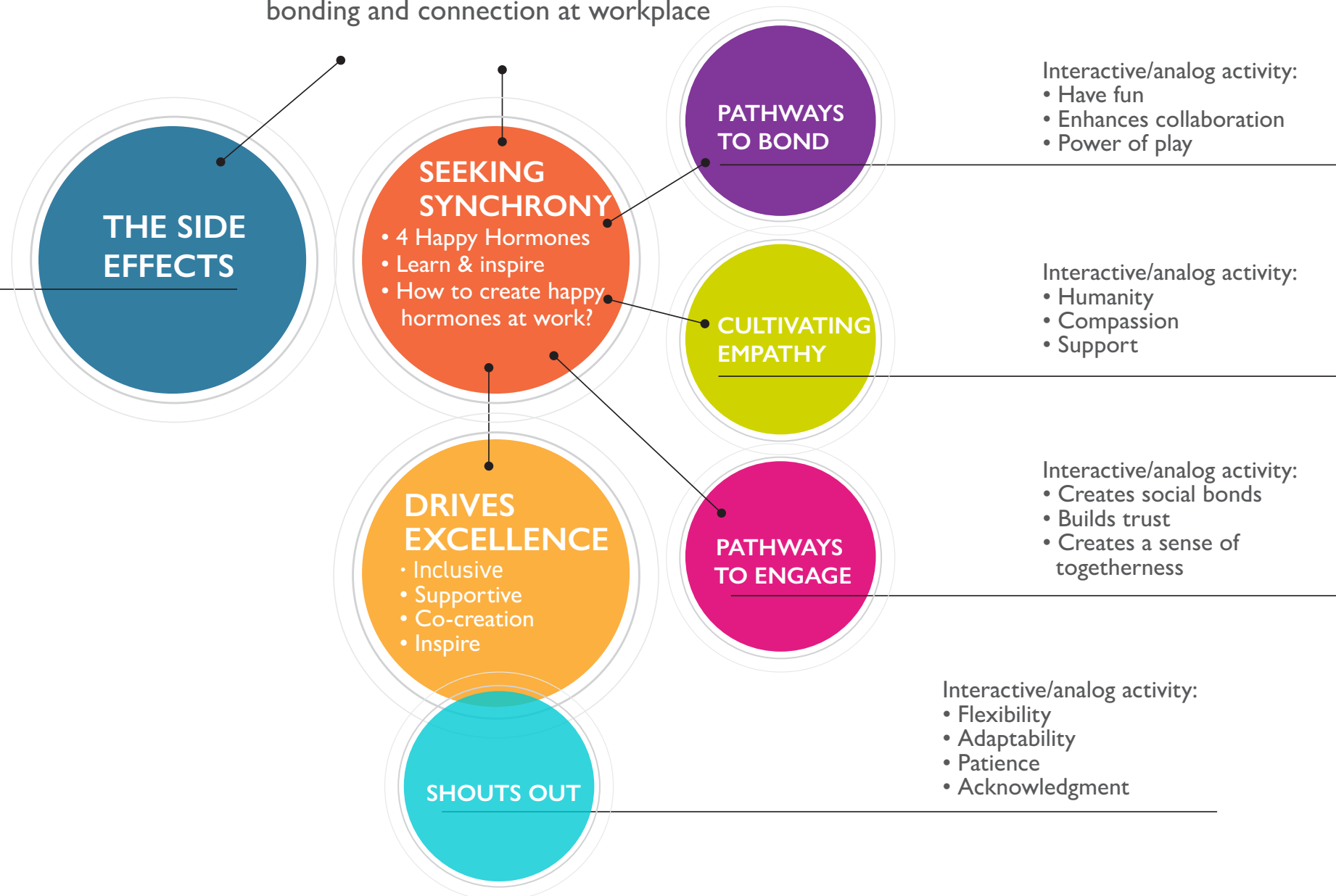

EMILY SCHMIDT
MA EXHIBITION & EXPERIENCE DESIGN

FASHION INSTITUTE OF TECHNOLOGY
School of Graduate Studies
272 West 27th St
New York, NY 10011



ST. ANN'S WAREHOUSE
45 Water Street
Brooklyn, NY 11201

CLIENT
GALLUP®

KEY PLAN

DISCLAIMER
This is an unpublished and proprietary work simultaneously protected under copyright, trade secret, and like laws of the United States and other countries. All rights reserved. These materials may not be reproduced, displayed, distributed, nor may the information therein be used or disclosed in whole or in part, without the express written permission of Emily Yeung Schmidt.

DRAWN BY: EMILY YEUNG SCHMIDT

SCALE: N/A

DATE: 12.9.2022

DRAWING TITLE:
CONCEPT DIAGRAM

DRAWING NO:

EX108

BUBBLE FLOOR PLAN & VISITOR'S CIRCULATION

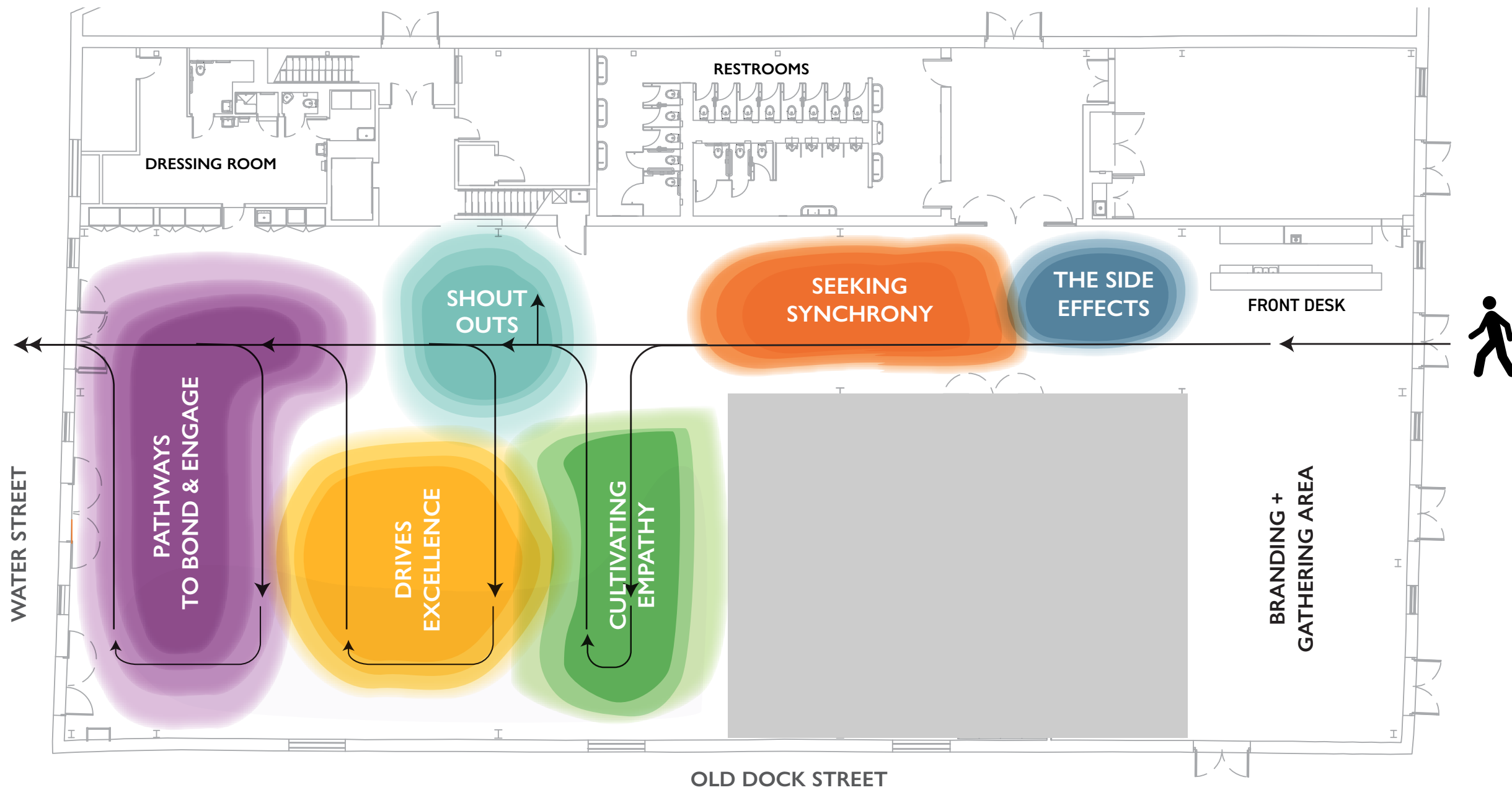

EMILY SCHMIDT
MA EXHIBITION & EXPERIENCE DESIGN

FASHION INSTITUTE OF TECHNOLOGY
School of Graduate Studies
272 West 27th St
New York, NY 10011



ST. ANN'S WAREHOUSE
45 Water Street
Brooklyn, NY 11201

CLIENT
GALLUP®

KEY PLAN

DISCLAIMER
This is an unpublished and proprietary work simultaneously protected under copyright, trade secret, and like laws of the United States and other countries. All rights reserved. These materials may not be reproduced, displayed, distributed, nor may the information therein be used or disclosed in whole or in part, without the express written permission of Emily Yeung Schmidt.

DRAWN BY: EMILY YEUNG SCHMIDT

SCALE: N/A

DATE: 12.9.2022

DRAWING TITLE:
BUBBLE FLOOR PLAN & VISITOR'S CIRCULATION

DRAWING NO:

EX109

AUDIENCE EMOTIONAL JOURNEY

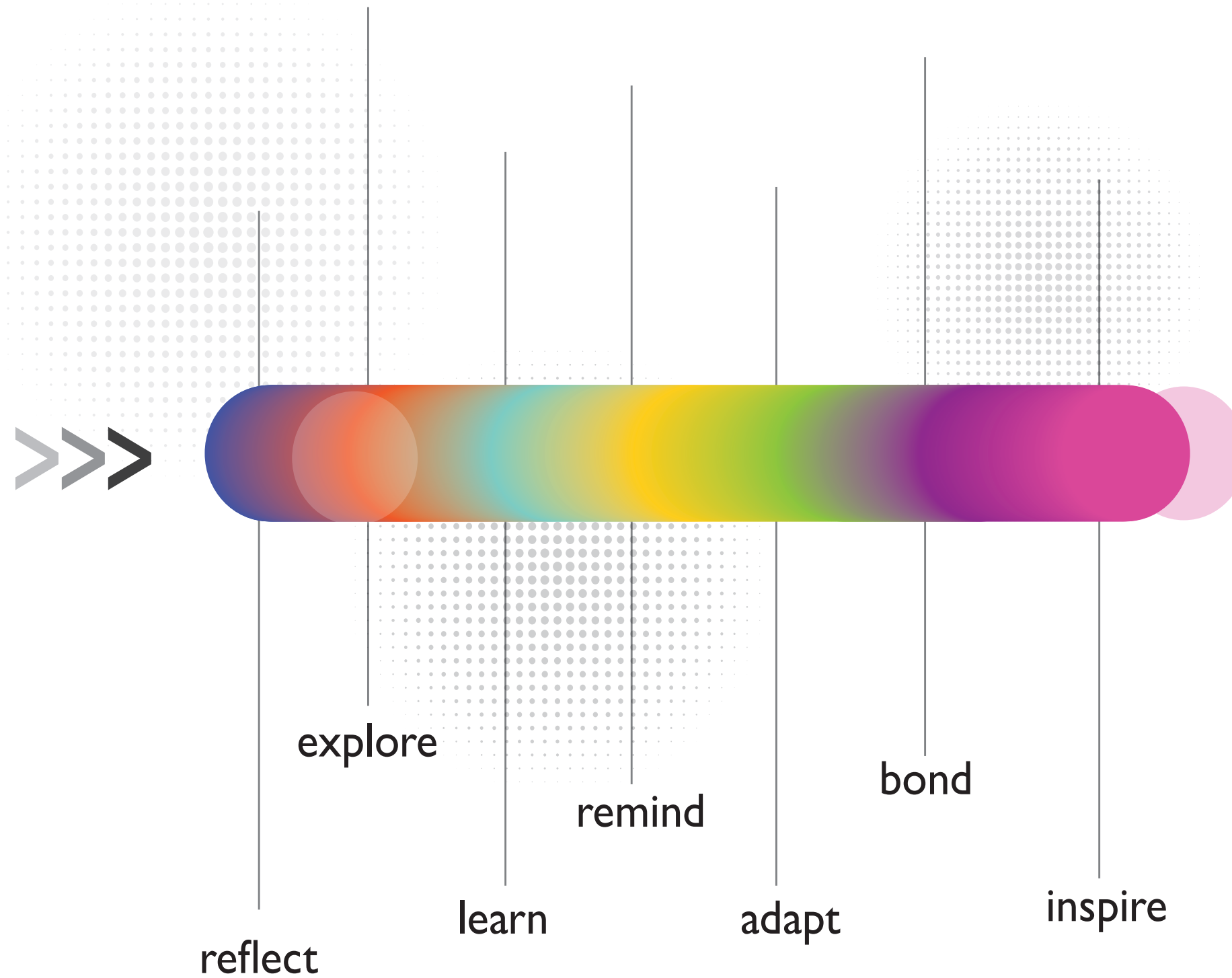

EMILY SCHMIDT
MA EXHIBITION & EXPERIENCE DESIGN

FASHION INSTITUTE OF TECHNOLOGY
School of Graduate Studies
272 West 27th St
New York, NY 10011



ST. ANN'S WAREHOUSE
45 Water Street
Brooklyn, NY 11201

CLIENT
GALLUP®

KEY PLAN

DISCLAIMER
This is an unpublished and proprietary work simultaneously protected under copyright, trade secret, and like laws of the United States and other countries. All rights reserved. These materials may not be reproduced, displayed, distributed, nor may the information therein be used or disclosed in whole or in part, without the express written permission of Emily Yeung Schmidt.

DRAWN BY: EMILY YEUNG SCHMIDT

SCALE: N/A

DATE: 12.9.2022

DRAWING TITLE:
**AUDIENCE
EMOTIONAL JOURNEY**

DRAWING NO:

EX110



EX120 RENDERINGS

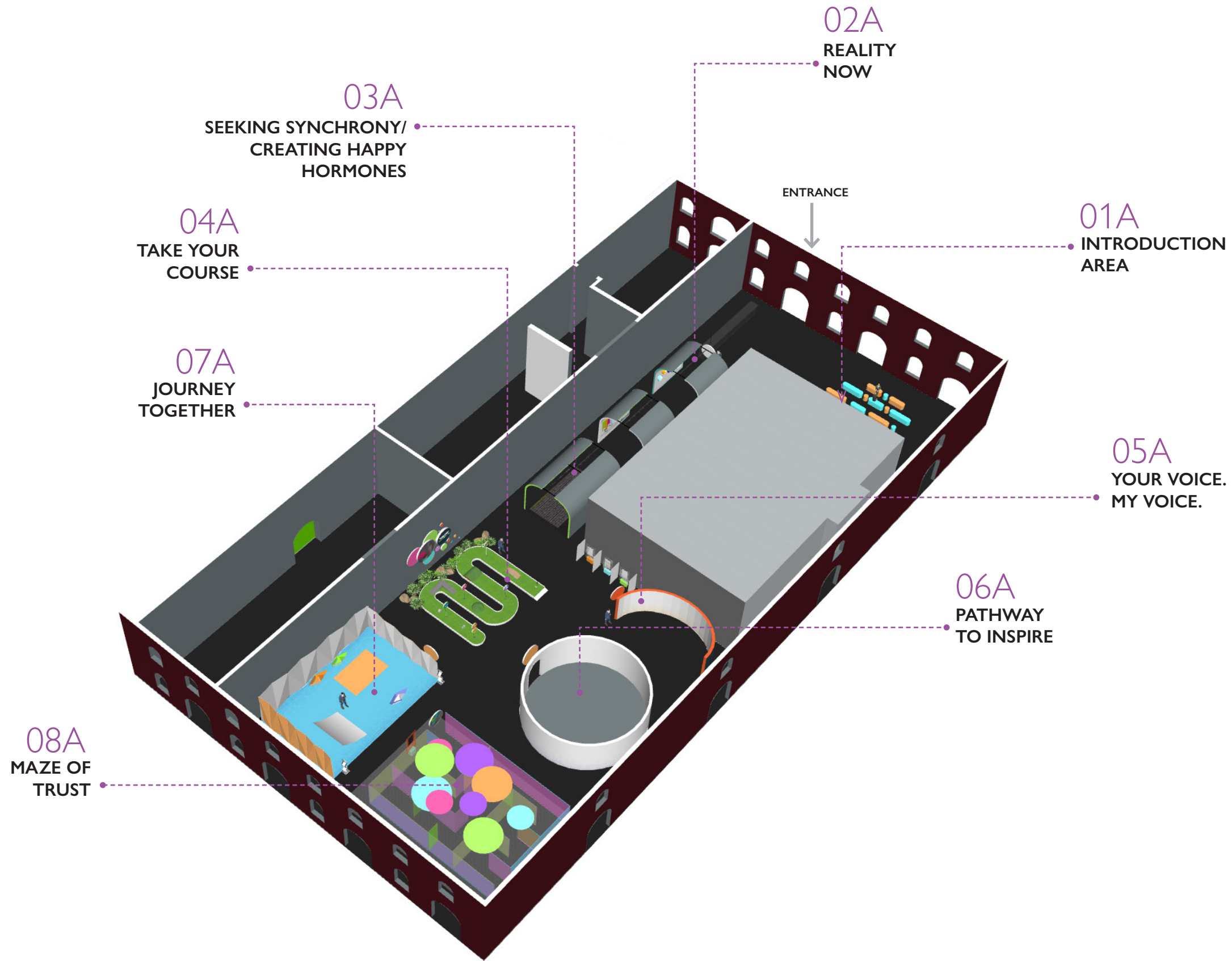

EMILY SCHMIDT
MA EXHIBITION & EXPERIENCE DESIGN

FASHION INSTITUTE OF TECHNOLOGY
School of Graduate Studies
272 West 27th St
New York, NY 10011



ST. ANN'S WAREHOUSE
45 Water Street
Brooklyn, NY 11201

CLIENT
GALLUP®

KEY PLAN

DISCLAIMER
This is an unpublished and proprietary work simultaneously protected under copyright, trade secret, and like laws of the United States and other countries. All rights reserved. These materials may not be reproduced, displayed, distributed, nor may the information therein be used or disclosed in whole or in part, without the express written permission of Emily Yeung Schmidt.

DRAWN BY: EMILY YEUNG SCHMIDT

SCALE: N/A

DATE: 12.9.2022

DRAWING TITLE:
EXHIBITION AXON

DRAWING NO:

EX121



EMILY SCHMIDT
MA EXHIBITION & EXPERIENCE DESIGN

FASHION INSTITUTE OF TECHNOLOGY
School of Graduate Studies
272 West 27th St
New York, NY 10011

in-sync

ST. ANN'S WAREHOUSE
45 Water Street
Brooklyn, NY 11201

CLIENT
GALLUP®

KEY PLAN

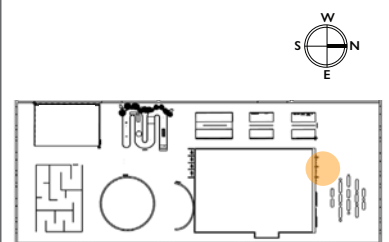

DISCLAIMER
This is an unpublished and proprietary work simultaneously protected under copyright, trade secret, and like laws of the United States and other countries. All rights reserved. These materials may not be reproduced, displayed, distributed, nor may the information therein be used or disclosed in whole or in part, without the express written permission of Emily Yeung Schmidt.

DRAWN BY: EMILY YEUNG SCHMIDT

SCALE: N/A

DATE: 12.9.2022

DRAWING TITLE:

EXHIBITION ENTRY

DRAWING NO:

EX122



EMILY SCHMIDT
MA EXHIBITION & EXPERIENCE DESIGN

FASHION INSTITUTE OF TECHNOLOGY
School of Graduate Studies
272 West 27th St
New York, NY 10011

in-sync

ST. ANN'S WAREHOUSE
45 Water Street
Brooklyn, NY 11201

CLIENT
GALLUP®

KEY PLAN

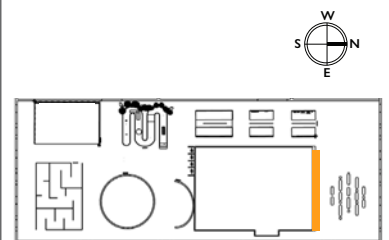

DISCLAIMER
This is an unpublished and proprietary work simultaneously protected under copyright, trade secret, and like laws of the United States and other countries. All rights reserved. These materials may not be reproduced, displayed, distributed, nor may the information therein be used or disclosed in whole or in part, without the express written permission of Emily Yeung Schmidt.

DRAWN BY: EMILY YEUNG SCHMIDT

SCALE: N/A

DATE: 12.9.2022

DRAWING TITLE:

**EXHIBITION
INTRODUCTION**

DRAWING NO:

EX123

01A

EXHIBITION INTRODUCTION

When visitors enter the exhibition, they will immediately be **enchanted by the vibrancy, cheer and boldness of In-Sync branding and spatial design.** In-Sync's graphic look & feel is contemporary, approachable and clean. It evokes team spirit and partnerships. **A strong graphic statement of 3D + transparent layerings + rounded shapes and lines (symbols which evoke unity), speak the story of synchronization.** St. Ann's Warehouse, a 24-foot ceiling interior with a truss system throughout the space is pictured above. Acoustic suede materials will be used for seating and will also absorb echo.



EMILY SCHMIDT
MA EXHIBITION & EXPERIENCE DESIGN

FASHION INSTITUTE OF TECHNOLOGY
School of Graduate Studies
272 West 27th St
New York, NY 10011

in-sync

ST. ANN'S WAREHOUSE
45 Water Street
Brooklyn, NY 11201

CLIENT
GALLUP®

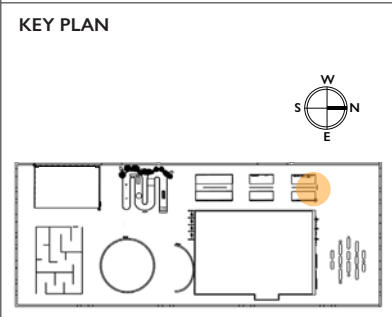

DISCLAIMER
This is an unpublished and proprietary work simultaneously protected under copyright, trade secret, and like laws of the United States and other countries. All rights reserved. These materials may not be reproduced, displayed, distributed, nor may the information therein be used or disclosed in whole or in part, without the express written permission of Emily Yeung Schmidt.

DRAWN BY: EMILY YEUNG SCHMIDT

SCALE: N/A

DATE: 12.9.2022

DRAWING TITLE:
ENTERING CORRIDORS

DRAWING NO:

EX124

02A

REALITY NOW

Upon embarking on the In-Sync journey, visitors will find a poster with a message **“To be in-sync, please put down your phone. Enjoy the Power of Play!”** At the 1st corridor to the left, visitors reflect upon the familiar post-pandemic side effects that include social isolation, disengagement and loneliness. To the right, are post-pandemic artifacts that most of us recognize: a backpack, a laptop with virtual meeting on the screen, airpods, sanitizing wipes and a mask. **Here is our new normal!**



EMILY SCHMIDT
MA EXHIBITION & EXPERIENCE DESIGN

FASHION INSTITUTE OF TECHNOLOGY
School of Graduate Studies
272 West 27th St
New York, NY 10011

in-sync

ST. ANN'S WAREHOUSE
45 Water Street
Brooklyn, NY 11201

CLIENT
GALLUP®

KEY PLAN

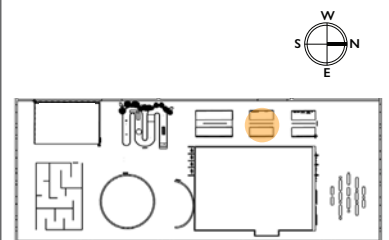

DISCLAIMER
This is an unpublished and proprietary work simultaneously protected under copyright, trade secret, and like laws of the United States and other countries. All rights reserved. These materials may not be reproduced, displayed, distributed, nor may the information therein be used or disclosed in whole or in part, without the express written permission of Emily Yeung Schmidt.

DRAWN BY: EMILY YEUNG SCHMIDT

SCALE: N/A

DATE: 12.9.2022

DRAWING TITLE:

SEEKING SYNCHRONY

DRAWING NO:

EX125

03A

SEEKING SYNCHRONY

Visitors enter the 2nd corridor to **discover Movement Synchrony** and the importance of applying the theory to our current work climate. **They also learn about the four happy hormones on the right panel — Dopamine, Oxytocin, Serotonin and Endorphin (D.O.S.E.) — and discover why it is essential for business performance.** These four happy hormones and Movement Synchrony are inter-related and are keys to boost happiness, trust, and bonding at work.

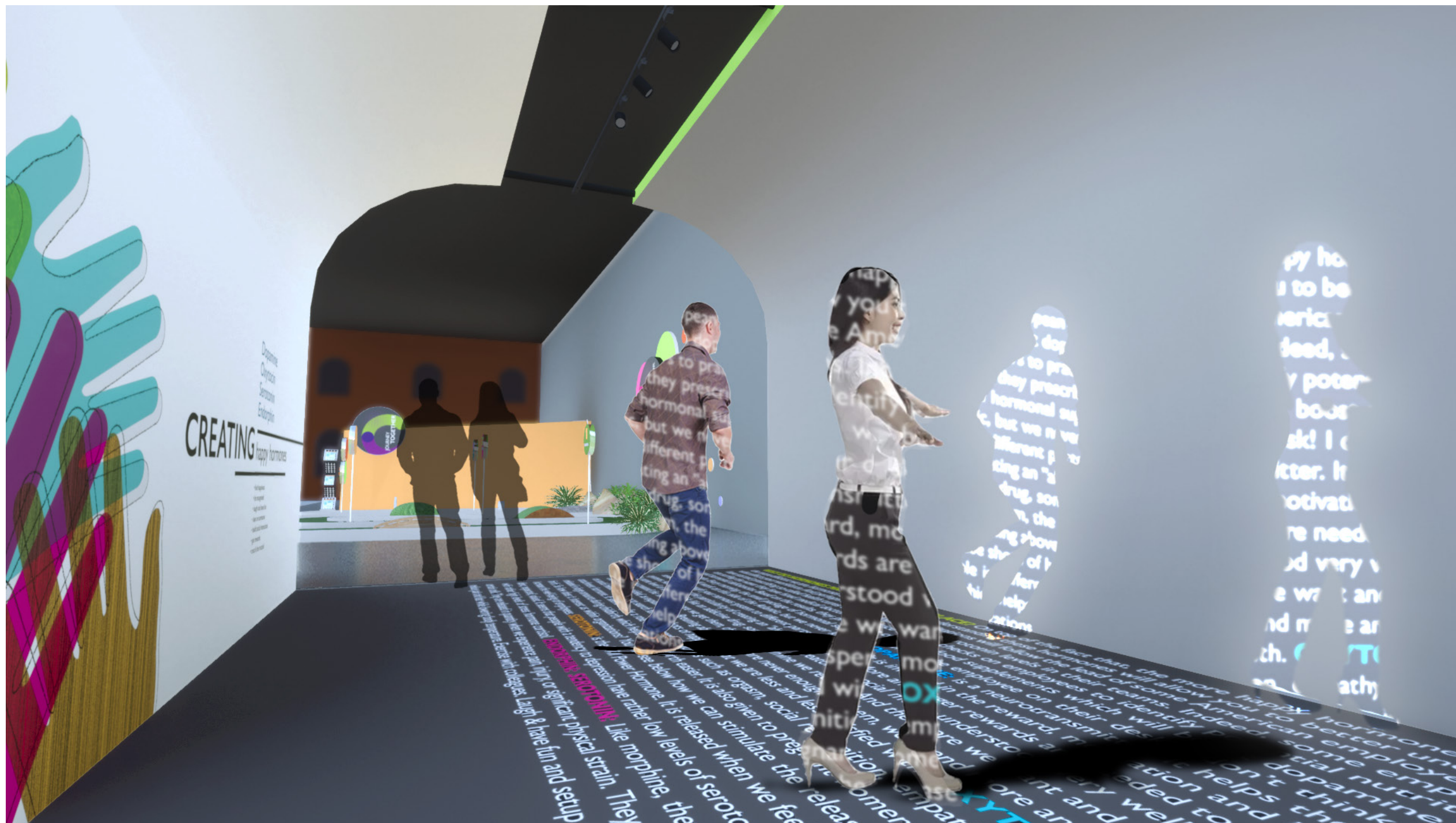

03A

CREATING HAPPY HORMONES

Visitors enter the last corridor. Through the interactive floor, visitors step on the typographic area to read the content of four happy hormones. They see themselves on the wall and the interaction process starts. It is a spontaneous way to engage with each other. Visitors will learn that happy hormones are naturally occurring in their bodies when they are excited, engaged, and motivated. The Power of Play empowers team work, trust, creativity and happiness in the workplace.

EMILY SCHMIDT
MA EXHIBITION & EXPERIENCE DESIGN

FASHION INSTITUTE OF TECHNOLOGY
School of Graduate Studies
272 West 27th St
New York, NY 10011

in-sync

ST. ANN'S WAREHOUSE
45 Water Street
Brooklyn, NY 11201

CLIENT
GALLUP®

KEY PLAN

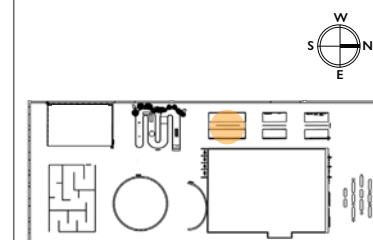

DISCLAIMER

This is an unpublished and proprietary work simultaneously protected under copyright, trade secret, and like laws of the United States and other countries. All rights reserved. These materials may not be reproduced, displayed, distributed, nor may the information therein be used or disclosed in whole or in part, without the express written permission of Emily Yeung Schmidt.

DRAWN BY: EMILY YEUNG SCHMIDT

SCALE: N/A

DATE: 12.9.2022

DRAWING TITLE:

CREATING HAPPY HORMONES

DRAWING NO:

EX126



04A

TAKE YOUR COURSE

After passing through the last corridor, visitors will find a mini-golf course game called “Take Your Course” to learn **post-pandemic leadership skills** — **patience, adaptability, flexibility, honesty and empathy**. This activity can be played solo or with a few partners competing to be the first to make it to the final hole.

EMILY SCHMIDT

MA EXHIBITION & EXPERIENCE DESIGN

CREATING HAPPY

HORMONES OF TECHNOLOGY

School of Graduate Studies

272 West 27th St

New York, NY 10011

in-sync

ST. ANN'S WAREHOUSE

45 Water Street

Brooklyn, NY 11201

CLIENT

GALLUP®

KEY PLAN

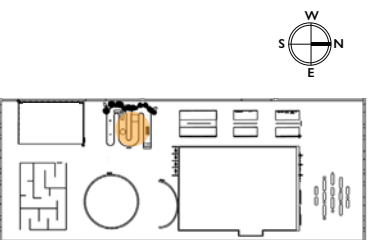

DISCLAIMER

This is an unpublished and proprietary work simultaneously protected under copyright, trade secret, and like laws of the United States and other countries. All rights reserved. These materials may not be reproduced, displayed, distributed, nor may the information therein be used or disclosed in whole or in part, without the express written permission of Emily Yeung Schmidt.

DRAWN BY: EMILY YEUNG SCHMIDT

SCALE: N/A

DATE: 12.9.2022

DRAWING TITLE:

TAKE YOUR COURSE

DRAWING NO:

EX127



EMILY SCHMIDT
MA EXHIBITION & EXPERIENCE DESIGN

FASHION INSTITUTE OF TECHNOLOGY
School of Graduate Studies
272 West 27th St
New York, NY 10011

in-sync

ST. ANN'S WAREHOUSE
45 Water Street
Brooklyn, NY 11201

CLIENT
GALLUP®

KEY PLAN

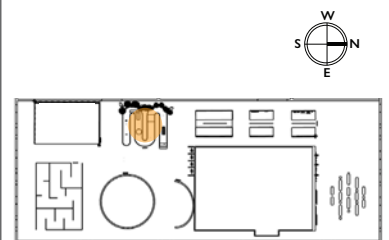

DISCLAIMER
This is an unpublished and proprietary work simultaneously protected under copyright, trade secret, and like laws of the United States and other countries. All rights reserved. These materials may not be reproduced, displayed, distributed, nor may the information therein be used or disclosed in whole or in part, without the express written permission of Emily Yeung Schmidt.

DRAWN BY: EMILY YEUNG SCHMIDT

SCALE: N/A

DATE: 12.9.2022

DRAWING TITLE:

TAKE YOUR COURSE

DRAWING NO:

EX128

04A

TAKE YOUR COURSE (cont.)

When the visitors hit the ball into the holes, the light will shine from the holes triggered by the motion sensor. The light stays on for 15 seconds and then shuts off. After visitors make it to the last hole, the Gobo light will immediately shine on the floor surface and say “You just released Serotonin and Endorphin! — The Will Power & Reward hormones!” Serotonin is also known as a hormone of leaders and Endorphins reduce stress, anxiety and relieve pain.



05A

YOUR VOICE. MY VOICE.

As visitors approach “Your Voice. My Voice.” area, they will find 3 touchscreens. Facilitators will be presented to assist visitors. Visitors choose either the leader or employee option to answer a few questions on touchscreens: “What are the most challenging issues at your workplace during the post-pandemic work environment?” Data will transfer to the a hard-drive and then to the iPads that are embedded inside the curved wall, allowing visitors to read their concerns or feedback. Their voices will be updated constantly.

EMILY SCHMIDT
MA EXHIBITION & EXPERIENCE DESIGN

FASHION INSTITUTE OF TECHNOLOGY
School of Graduate Studies
272 West 27th St
New York, NY 10011

in-sync

ST. ANN'S WAREHOUSE
45 Water Street
Brooklyn, NY 11201

CLIENT
GALLUP®

KEY PLAN

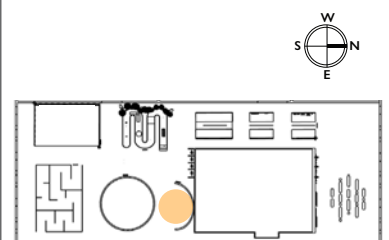

DISCLAIMER
This is an unpublished and proprietary work simultaneously protected under copyright, trade secret, and like laws of the United States and other countries. All rights reserved. These materials may not be reproduced, displayed, distributed, nor may the information therein be used or disclosed in whole or in part, without the express written permission of Emily Yeung Schmidt.

DRAWN BY: EMILY YEUNG SCHMIDT

SCALE: N/A

DATE: 12.9.2022

DRAWING TITLE:
**YOUR VOICE.
MY VOICE.**

DRAWING NO:

EX129



“When we get together now, let’s be intentional and meaningful. We should embrace the opportunity to share and inspire one another.”

ANONYMOUS VOICE FROM A LEADER

“Too many virtual meetings even when we are in the office. Everyone has airpods on them, it is so hard to make a conversation these days. I feel isolated.”

ANONYMOUS VOICE FROM AN EMPLOYEE

05A

YOUR VOICE. MY VOICE. (cont.)

Visitors can read the honest anonymous feelings and challenges from either the leaders’ or employees’ perspectives by peeking through holes in the circular wall. **The aim is to create empathy for each other. This layers of transparency and honesty is essential for today’s norm — to put yourself in someone’s shoes.**

EMILY SCHMIDT
MA EXHIBITION & EXPERIENCE DESIGN

FASHION INSTITUTE OF TECHNOLOGY
School of Graduate Studies
272 West 27th St
New York, NY 10011

in-sync

ST. ANN’S WAREHOUSE
45 Water Street
Brooklyn, NY 11201

CLIENT
GALLUP®

KEY PLAN

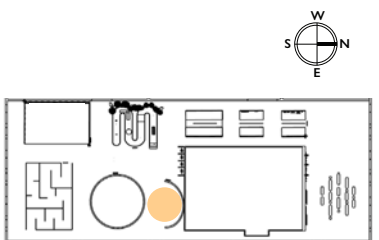

DISCLAIMER
This is an unpublished and proprietary work simultaneously protected under copyright, trade secret, and like laws of the United States and other countries. All rights reserved. These materials may not be reproduced, displayed, distributed, nor may the information therein be used or disclosed in whole or in part, without the express written permission of Emily Yeung Schmidt.

DRAWN BY: EMILY YEUNG SCHMIDT

SCALE: N/A

DATE: 12.9.2022

DRAWING TITLE:

**YOUR VOICE.
NO VOICE.**

DRAWING NO:

EX130

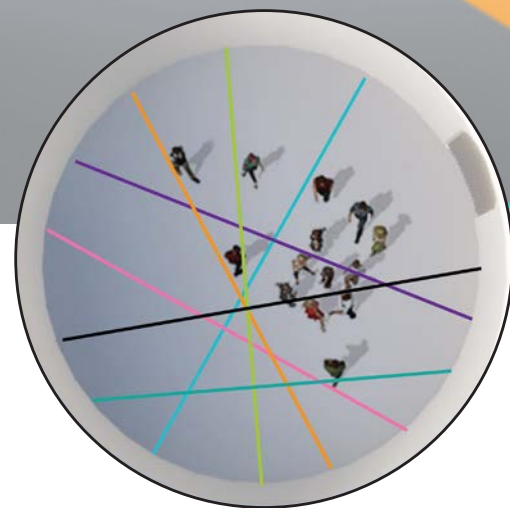
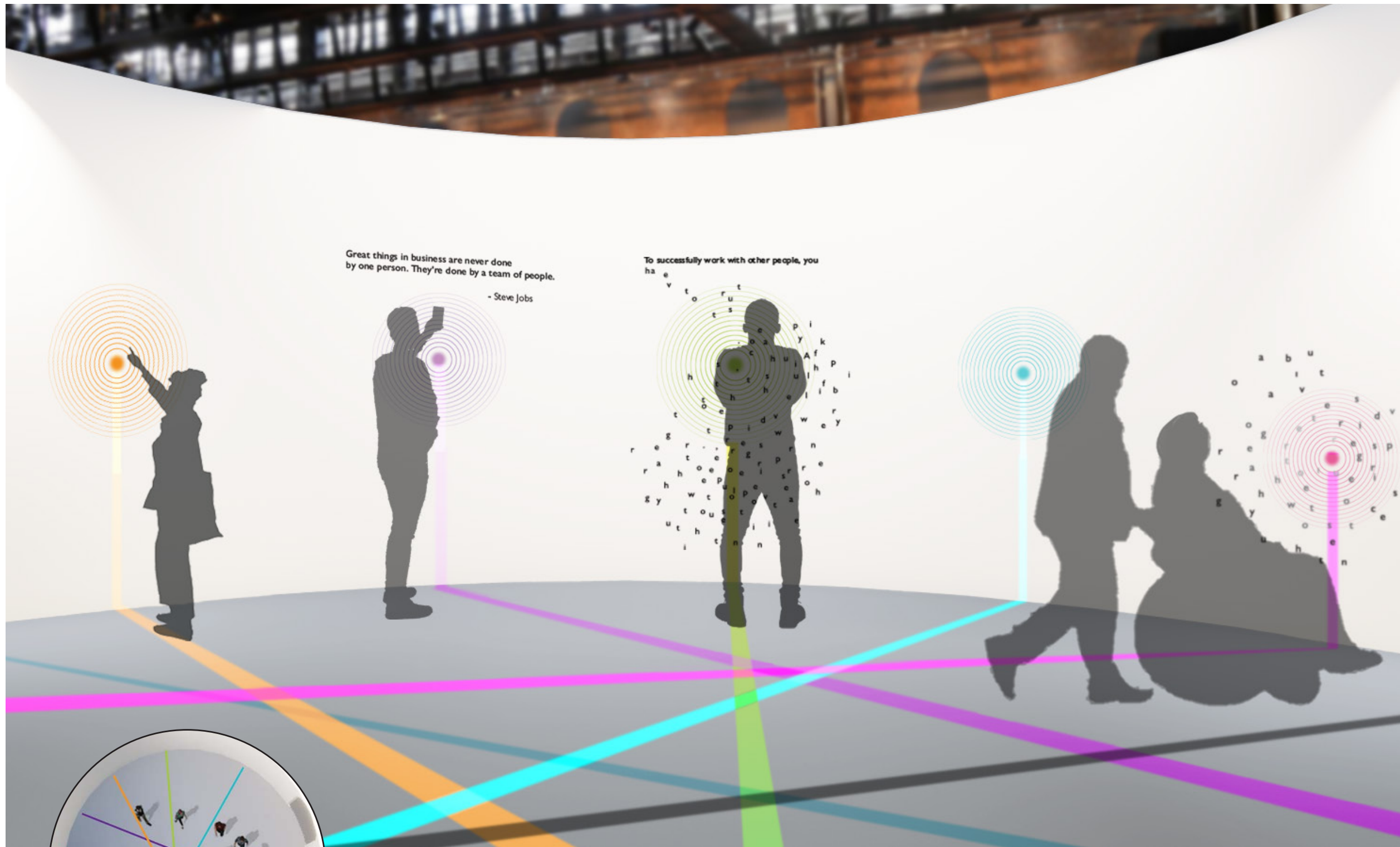

EXHIBIT PLAN VIEW

06A

PATHWAY TO INSPIRE

When visitors enter "Pathway To Inspire", they will see pathways crossing all over the floor. If they follow any of the pathways to the end and then activate the buttons on the wall, letters will appear and spread out to form a quote from an influential leader around the world. **It is important for great leaders to get inspired, receive advice and take action for their organizations and teams.** "Pathway To Inspire" aims to inspire, remind and reflect today's leaderships skills that are essential to the post-pandemic work environment.

EMILY SCHMIDT
MA EXHIBITION & EXPERIENCE DESIGN

FASHION INSTITUTE OF TECHNOLOGY
School of Graduate Studies
272 West 27th St
New York, NY 10011

in-sync

ST. ANN'S WAREHOUSE
45 Water Street
Brooklyn, NY 11201

CLIENT
GALLUP®

KEY PLAN

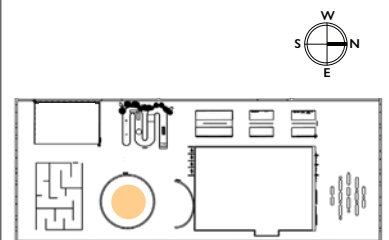

DISCLAIMER
This is an unpublished and proprietary work simultaneously protected under copyright, trade secret, and like laws of the United States and other countries. All rights reserved. These materials may not be reproduced, displayed, distributed, nor may the information therein be used or disclosed in whole or in part, without the express written permission of Emily Yeung Schmidt.

DRAWN BY: EMILY YEUNG SCHMIDT

SCALE: N/A

DATE: 12.9.2022

DRAWING TITLE:
PATHWAY TO INSPIRE

DRAWING NO:

EX131

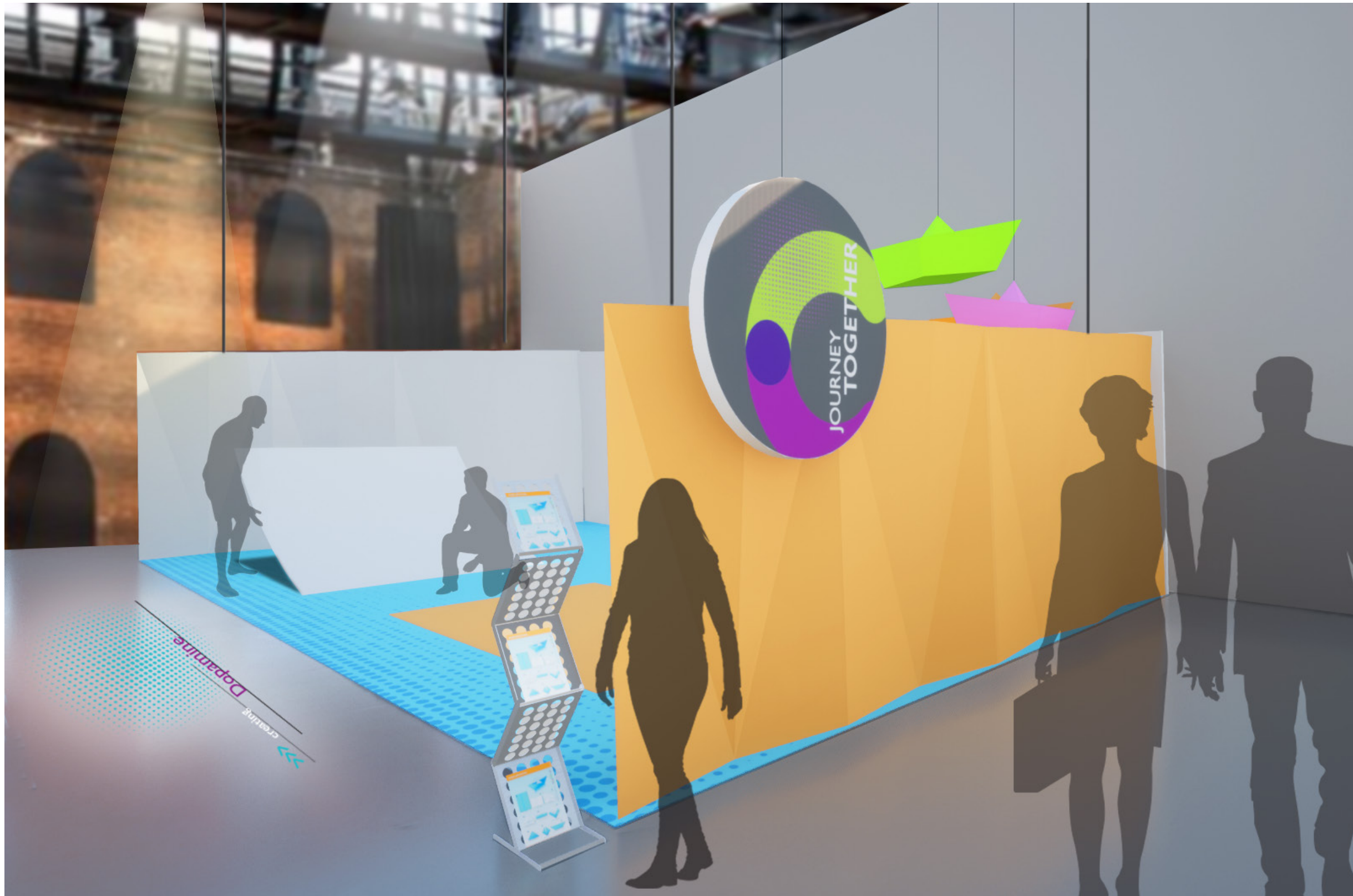

EMILY SCHMIDT
MA EXHIBITION & EXPERIENCE DESIGN

FASHION INSTITUTE OF TECHNOLOGY
School of Graduate Studies
272 West 27th St
New York, NY 10011

in-sync

ST. ANN'S WAREHOUSE
45 Water Street
Brooklyn, NY 11201

CLIENT
GALLUP®

KEY PLAN

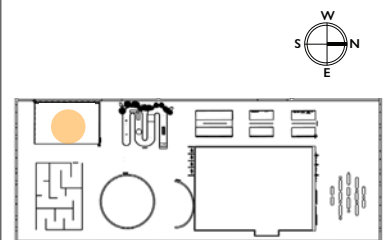

DISCLAIMER
This is an unpublished and proprietary work simultaneously protected under copyright, trade secret, and like laws of the United States and other countries. All rights reserved. These materials may not be reproduced, displayed, distributed, nor may the information therein be used or disclosed in whole or in part, without the express written permission of Emily Yeung Schmidt.

DRAWN BY: EMILY YEUNG SCHMIDT

SCALE: N/A

DATE: 12.9.2022

DRAWING TITLE:

JOURNEY TOGETHER

DRAWING NO:

EX132

07A

JOURNEY TOGETHER

As visitors enter the activity area of Journey Together, they will see a Gobo light projected on the floor labeled "Creating Dopamine". It is exciting to see the giant and colorful origami boats that are hanging from the truss!

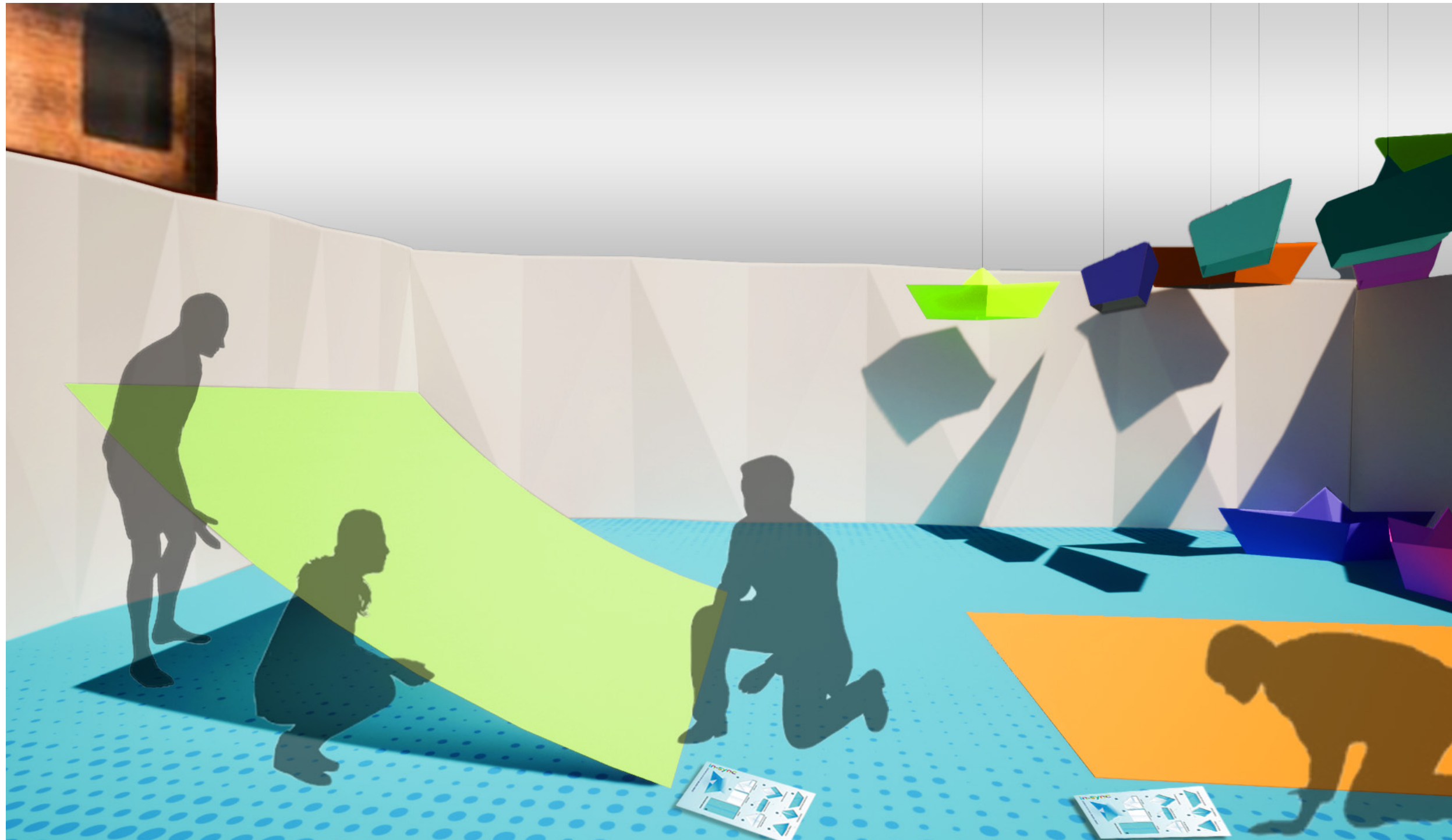

07A

JOURNEY TOGETHER (cont.)

“Journey Together” reflects the essentials of collaboration, inclusion and co-creation. Visitors learn how to fold the origami boats from instructions that are provided. **Meaningful communication and conversation** can occur during the process. A facilitator is available to help with materials.

EMILY SCHMIDT
MA EXHIBITION & EXPERIENCE DESIGN

FASHION INSTITUTE OF TECHNOLOGY
School of Graduate Studies
272 West 27th St
New York, NY 10011

in-sync

ST. ANN'S WAREHOUSE
45 Water Street
Brooklyn, NY 11201

CLIENT
GALLUP®

KEY PLAN

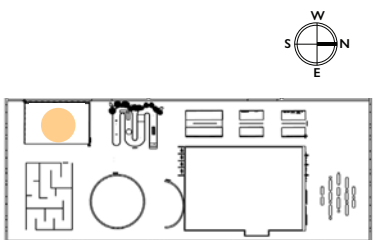

DISCLAIMER
This is an unpublished and proprietary work simultaneously protected under copyright, trade secret, and like laws of the United States and other countries. All rights reserved. These materials may not be reproduced, displayed, distributed, nor may the information therein be used or disclosed in whole or in part, without the express written permission of Emily Yeung Schmidt.

DRAWN BY: EMILY YEUNG SCHMIDT

SCALE: N/A

DATE: 12.9.2022

DRAWING TITLE:

JOURNEY TOGETHER

DRAWING NO:

EX133



08A

MAZE OF TRUST

As visitors approach the **Maze of Trust**, they notice that it is made of transparent acrylic panels allowing them to be seen through by outsiders. **Maze of Trust** is a team icebreaker where all participants will be blindfolded except the leader. The leader will give instructions and guide the participants out of the maze through trust and clear communication.

EMILY SCHMIDT

MA EXHIBITION & EXPERIENCE DESIGN

FASHION INSTITUTE OF TECHNOLOGY
School of Graduate Studies
272 West 27th St
New York, NY 10011

in-sync

ST. ANN'S WAREHOUSE
45 Water Street
Brooklyn, NY 11201

CLIENT

GALLUP®

KEY PLAN

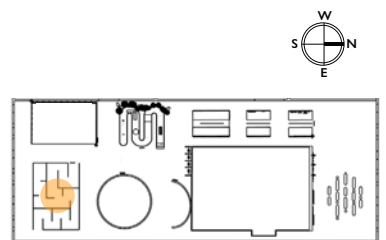

DISCLAIMER

This is an unpublished and proprietary work simultaneously protected under copyright, trade secret, and like laws of the United States and other countries. All rights reserved. These materials may not be reproduced, displayed, distributed, nor may the information therein be used or disclosed in whole or in part, without the express written permission of Emily Yeung Schmidt.

DRAWN BY: EMILY YEUNG SCHMIDT

SCALE: N/A

DATE: 12.9.2022

DRAWING TITLE:

MAZE OF TRUST

DRAWING NO:

EX134

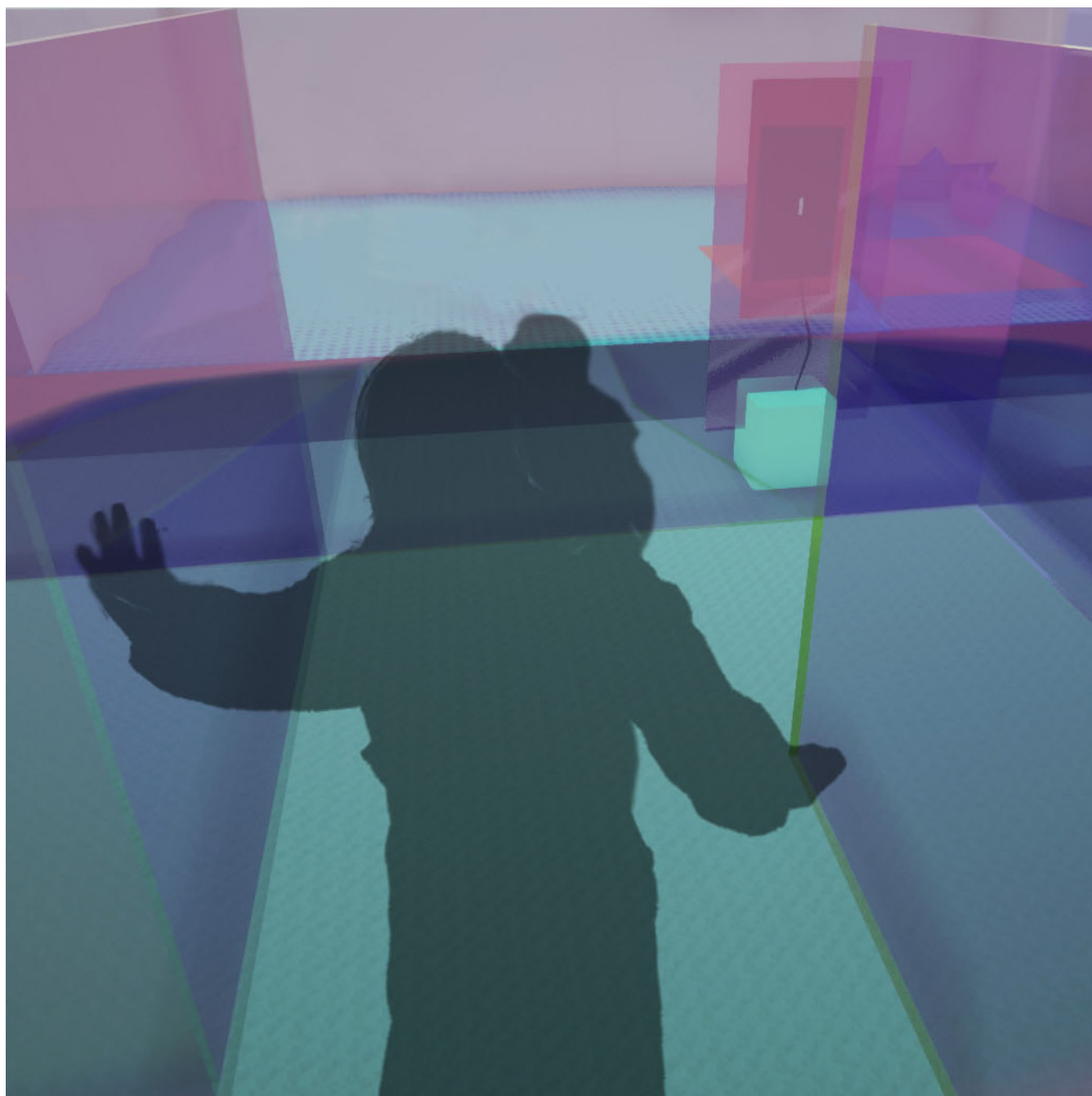

08A

MAZE OF TRUST (cont.)

In today's climate, leaders have to be confident, communicative, empathetic and courageous. A great leader acts in the face of fear and uncertainty and inspires others to follow with trust and dedication.

EMILY SCHMIDT

MA EXHIBITION & EXPERIENCE DESIGN

FASHION INSTITUTE OF TECHNOLOGY
School of Graduate Studies
272 West 27th St
New York, NY 10011

in-sync

ST. ANN'S WAREHOUSE
45 Water Street
Brooklyn, NY 11201

CLIENT

GALLUP®

KEY PLAN

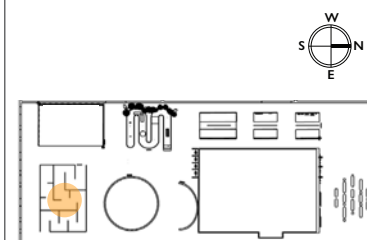

DISCLAIMER

This is an unpublished and proprietary work simultaneously protected under copyright, trade secret, and like laws of the United States and other countries. All rights reserved. These materials may not be reproduced, displayed, distributed, nor may the information therein be used or disclosed in whole or in part, without the express written permission of Emily Yeung Schmidt.

DRAWN BY: EMILY YEUNG SCHMIDT

SCALE: N/A

DATE: 12.9.2022

DRAWING TITLE:

MAZE OF TRUST

DRAWING NO:

EX135



EMILY SCHMIDT
MA EXHIBITION & EXPERIENCE DESIGN

FASHION INSTITUTE OF TECHNOLOGY
School of Graduate Studies
272 West 27th St
New York, NY 10011



ST. ANN'S WAREHOUSE
45 Water Street
Brooklyn, NY 11201

CLIENT
GALLUP®

KEY PLAN

DISCLAIMER
This is an unpublished and proprietary work simultaneously protected under copyright, trade secret, and like laws of the United States and other countries. All rights reserved. These materials may not be reproduced, displayed, distributed, nor may the information therein be used or disclosed in whole or in part, without the express written permission of Emily Yeung Schmidt.

DRAWN BY: EMILY YEUNG SCHMIDT

SCALE: N/A

DATE: 12.9.2022

DRAWING TITLE:

SUMMARY:
6 EXHIBITION AREAS

DRAWING NO:

EX136



EMILY SCHMIDT
MA EXHIBITION & EXPERIENCE DESIGN

FASHION INSTITUTE OF TECHNOLOGY
School of Graduate Studies
272 West 27th St
New York, NY 10011

in-sync

ST. ANN'S WAREHOUSE
45 Water Street
Brooklyn, NY 11201

CLIENT
GALLUP®

KEY PLAN

DISCLAIMER
This is an unpublished and proprietary work simultaneously protected under copyright, trade secret, and like laws of the United States and other countries. All rights reserved. These materials may not be reproduced, displayed, distributed, nor may the information therein be used or disclosed in whole or in part, without the express written permission of Emily Yeung Schmidt.

DRAWN BY: EMILY YEUNG SCHMIDT

SCALE: N/A

DATE: 12.9.2022

DRAWING TITLE:

**3D MODEL PHOTO
SURVEY**

DRAWING NO:

EX137



EX200 **SCHEDULES & LISTS**

GRAPHIC SCHEDULE

| ENTRY (001) | SIGN TYPE | DESCRIPTION |
|--------------|-----------|-----------------------|
| 001A.01.GR01 | C | Wayfinding |
| 001A.01.GR02 | C | Wayfinding |
| 001A.01.GR03 | C | Wayfinding |
| 001A.01.GR04 | I | Water Street mural |
| 001A.01.GR05 | M | Water Street banner |
| 001A.01.GR06 | F | Plymouth Street mural |
| 001A.02.GR01 | I | Entry mural |
| 001A.02.GR02 | A0 | Entry signage |
| 001A.02.GR03 | I | Exit door |
| 001A.02.GR04 | F | Poster |
| 001A.02.GR05 | F | Poster |
| 001A.02.GR06 | F | Poster |
| 001A.02.GR07 | I | Exit mural |
| 001A.02.GR08 | F | Poster |
| 001A.01.GR09 | F | Poster |

| INTRODUCTION (01) | SIGN TYPE | DESCRIPTION |
|-------------------|-----------|--------------------|
| 01A.01.GR01 | A1 | Introduction panel |
| 01A.01.GR02 | A2 | Introduction panel |
| 01A.01.GR03 | A3 | Introduction panel |
| 01A.01.GR04 | A4 | Introduction panel |
| 01A.02.GR01 | C | Directive |
| 01A.02.GR02 | A0 | Area graphic |

| CORRIDOR (02) | SIGN TYPE | DESCRIPTION |
|---------------|-----------|-----------------|
| 02A.01.GR01 | A1 | Content graphic |
| 02A.01.GR02 | A2 | Content graphic |
| 02A.01.GR03 | A3 | Content graphic |
| 02A.01.GR04 | A4 | Content graphic |
| 02A.01.GR05 | A1 | Content graphic |
| 02A.01.GR06 | A1 | Content graphic |
| 02A.02.GR07 | A1 | Content graphic |
| 02A.01.GR08 | A2 | Content graphic |
| 02A.01.GR09 | A3 | Content graphic |
| 02A.01.GR010 | A4 | Content graphic |
| 02A.01.GR011 | A1 | Content graphic |

| CORRIDOR (03) | SIGN TYPE | DESCRIPTION |
|---------------|-----------|-----------------------|
| 03A.01.GR01 | A1 | Content graphic |
| 03A.01.GR02 | K | Interactive projector |

| AREA (04) | SIGN TYPE | DESCRIPTION |
|-------------|-----------|-------------------------------|
| 04A.01.GR01 | A0 | Area graphic |
| 04A.01.GR02 | A0 | Content graphic |
| 04A.01.GR03 | D | Content graphic |
| 04A.01.GR04 | D | Content graphic |
| 04A.01.GR05 | D | Content graphic |
| 04A.01.GR06 | D | Content graphic |
| 04A.01.GR07 | D | Content graphic |
| 04A.01.L01 | J | Custom Gobo graphic projector |

| AREA (05) | SIGN TYPE | DESCRIPTION |
|-------------|-----------|-------------------------------|
| 05A.01.GR01 | A1 | Content graphic |
| 05A.01.GR02 | A0 | Area graphic |
| 05A.01.GR03 | A1 | Content graphic |
| 05A.01.AV01 | L | Digital touchscreen |
| 05A.01.AV02 | L1 | Ipad/screen |
| 05A.01.L04 | J | Custom Gobo graphic projector |

| AREA (06) | SIGN TYPE | DESCRIPTION |
|-------------|-----------|-------------------------------|
| 06A.01.GR01 | A0 | Area sign |
| 06A.01.GR02 | G | Content graphic |
| 06A.01.AV01 | K | Mapping projector |
| 06A.01.L01 | J | Custom Gobo graphic projector |

| AREA (07) | SIGN TYPE | DESCRIPTION |
|-------------|-----------|-------------------------------|
| 07A.01.GR01 | A0 | Area sign |
| 07A.01.GR02 | E | Directive |
| 07A.01.GR03 | H | Content graphic |
| 07A.01.L02 | J | Custom Gobo graphic projector |

| AREA (08) | SIGN TYPE | DESCRIPTION |
|-------------|-----------|-------------------------------|
| 08A.01.GR01 | A0 | Area sign |
| 08A.01.GR02 | E | Directive |
| 08A.01.L03 | J | Custom Gobo graphic projector |

EMILY SCHMIDT
MA EXHIBITION & EXPERIENCE DESIGN

FASHION INSTITUTE OF TECHNOLOGY
School of Graduate Studies
272 West 27th St
New York, NY 10011



ST. ANN'S WAREHOUSE
45 Water Street
Brooklyn, NY 11201

CLIENT
GALLUP®

KEY PLAN

DISCLAIMER
This is an unpublished and proprietary work simultaneously protected under copyright, trade secret, and like laws of the United States and other countries. All rights reserved. These materials may not be reproduced, displayed, distributed, nor may the information therein be used or disclosed in whole or in part, without the express written permission of Emily Yeung Schmidt.

DRAWN BY: EMILY YEUNG SCHMIDT

SCALE: N/A

DATE: 12.9.2022

DRAWING TITLE:
GRAPHIC SCHEDULE

DRAWING NO:

EX201

GRAPHIC SPECIFICATION LIST

TYPE DESCRIPTION

- A0 Powder coated aluminum with dye-sublimation on aluminum by ALTO®
- A1 3/4 Thick white oak plywood with direct print and clear protective over-laminate
- A2 5" thick direct prints white ply wood
- A3 2" thick printed white ply wood
- A4 1/2" thick direct prints white ply wood
- B Sublimation print on 1/2" aluminum panels
- C Graphic prints on 1/2" acrylic sheet
- D Direct prints on 1/4" acrylic
- E A4 size direct prints on card stock Tyvek Paper
- F Direct prints on adhesive vinyl
- G Opaque stretch fabric on 240 GSM matte opaque tension fabric to be assembled with freestanding aluminum frame
- H Sublimation print on area rug
- I Sublimation print on Duraclear Vinyl
- J Graphic on custom GOBO projector
- K Interactive Projection Mapping
- L Digital graphic on Touchscreen
- M Disublimation graphic on sheer fabric with UV exterior coat

EMILY SCHMIDT
MA EXHIBITION & EXPERIENCE DESIGN

FASHION INSTITUTE OF TECHNOLOGY
School of Graduate Studies
272 West 27th St
New York, NY 10011



ST. ANN'S WAREHOUSE
45 Water Street
Brooklyn, NY 11201

CLIENT

GALLUP®

KEY PLAN

DISCLAIMER

This is an unpublished and proprietary work simultaneously protected under copyright, trade secret, and like laws of the United States and other countries. All rights reserved. These materials may not be reproduced, displayed, distributed, nor may the information therein be used or disclosed in whole or in part, without the express written permission of Emily Yeung Schmidt.

DRAWN BY: EMILY YEUNG SCHMIDT

SCALE: N/A

DATE: 12.9.2022











DRAWING TITLE:

**GRAPHIC
SPECIFICATION LIST**

DRAWING NO:

EX202

MATERIAL SCHEDULE

| MATERIAL | CODE | LOCATION | DESCRIPTION | THUMBNAIL |
|-------------------------|---------|---|--|---|
| ALUMINUM | X-ML-01 | ENTRY SIGNAGE | POWDER COATED EXTRUSION ALUMINUM (CUSTOM COLORS TO MATCH) |  |
| ALUMINUM | X-ML-02 | PATHWAY TO INSPIRE | 28MM TUBULAR ALUMINUM FRAME |  |
| ACOUSTICAL FABRIC | X-FB-01 | INTRODUCTION | CUSTOM SEATING |  |
| WOOD | X-WD-01 | CORRIDORS, TAKE YOUR COURSE AND YOUR VOICE. MY VOICE. | 3/4" THICK WHITE OAK PLYWOOD |  |
| ACOUSTIC PANELS | X-PN-01 | MAZE OF TRUST & TAKE YOUR COURSE | CUSTOM SIZES |  |
| ACRYLIC | X-VL-01 | MAZE OF TRUST | 2.5" CLEAR ACRYLIC SHEETS 5' X 8' by Acrylite |  |
| ARTIFICIAL GRASS | X-GR-01 | TAKE YOUR COURSE | GOLF COURSE COVER |  |
| CARPET | X-CP-01 | MAZE OF TRUST | CUT TO SIZE |  |
| 3M ADHESIVE TINTED FILM | X-TF-01 | MAZE OF TRUST | LAMINATED ON CLEAR VINYL |  |
| TENSION FABRIC | X-FB-02 | PATHWAY TO INSPIRE | TENSION FABRIC ROOM MADE FROM A TUBULAR ALUMINUM FRAME AND PRINTED FABRIC GRAPHIC SKIN |  |

EMILY SCHMIDT
MA EXHIBITION & EXPERIENCE DESIGN

FASHION INSTITUTE OF TECHNOLOGY
School of Graduate Studies
272 West 27th St
New York, NY 10011



ST. ANN'S WAREHOUSE
45 Water Street
Brooklyn, NY 11201

CLIENT
GALLUP®

KEY PLAN

DISCLAIMER
This is an unpublished and proprietary work simultaneously protected under copyright, trade secret, and like laws of the United States and other countries. All rights reserved. These materials may not be reproduced, displayed, distributed, nor may the information therein be used or disclosed in whole or in part, without the express written permission of Emily Yeung Schmidt.

DRAWN BY: EMILY YEUNG SCHMIDT

SCALE: N/A



DATE: 12.9.2022

DRAWING TITLE:
MATERIAL SCHEDULE

DRAWING NO:

EX203

LIGHTING SCHEDULE

| CODE | TYPE | MANUFACTURER | DESCRIPTION | THUMBNAIL |
|------|------------------------|--|--|---|
| L1 | LED TRACK LIGHT | WAC LIGHTING | LED2020 SILO X20 BEAM SHIFT TRACK HEAD. 2700K-4000K COLOR TEMPERATURE 15° SPOT TO 50° FLOOD |  |
| L2 | LED STRIP LIGHT | BYIBA LSV SILICONE BENDABLE LED | ACCENT LIGHT. 24V LED, 3000K AND CRI 90. LUMEN OUTPUT 630LM. OUTDOOR APPLICATION. |  |
| L3 | MOTION LIGHT | N/A | FABRICATOR TO ADVISE | N/A |
| L4 | CUSTOM GOBO PROJECTORS | GOBO SOURCE ECO SPOT LED B40E GOBO PROJECTOR | TRUSS MOUNTING. COLOR TEMPERATURE 6,000K. 2,400LM EFFECTIVE LUMINOUS FLUX. MEDIUM LEN: F=70MM/20 DEGREES: 28MM (11 IN) |  |

EMILY SCHMIDT
MA EXHIBITION & EXPERIENCE DESIGN

FASHION INSTITUTE OF TECHNOLOGY
School of Graduate Studies
272 West 27th St
New York, NY 10011



ST. ANN'S WAREHOUSE
45 Water Street
Brooklyn, NY 11201

CLIENT

GALLUP®

KEY PLAN

DISCLAIMER

This is an unpublished and proprietary work simultaneously protected under copyright, trade secret, and like laws of the United States and other countries. All rights reserved. These materials may not be reproduced, displayed, distributed, nor may the information therein be used or disclosed in whole or in part, without the express written permission of Emily Yeung Schmidt.

DRAWN BY: EMILY YEUNG SCHMIDT

SCALE: N/A

DATE: 12.9.2022





DRAWING TITLE:

LIGHTING SCHEDULE

DRAWING NO:

EX204

ARTIFACT SCHEDULE

| ARTIFACT | CODE | LOCATION | DESCRIPTION | QTY |
|---|--------------|-------------|-----------------------------|-----|
|  | 02A.01.AR01 | REALITY NOW | OBJECT - BACKPACK | 1 |
|  | 02A.01.AR02 | REALITY NOW | OBJECT - LAPTOP | 1 |
|  | 02A.01.AR03 | REALITY NOW | OBJECT - AIRPODS | 1 |
|  | 02A.01.AR014 | REALITY NOW | OBJECT - MASK | 1 |
|  | 02A.01.AR05 | REALITY NOW | OBJECT - DISINFECTING WIPES | 1 |

EMILY SCHMIDT
MA EXHIBITION & EXPERIENCE DESIGN

FASHION INSTITUTE OF TECHNOLOGY
School of Graduate Studies
272 West 27th St
New York, NY 10011



ST. ANN'S WAREHOUSE
45 Water Street
Brooklyn, NY 11201

CLIENT
GALLUP®

KEY PLAN

DISCLAIMER
This is an unpublished and proprietary work simultaneously protected under copyright, trade secret, and like laws of the United States and other countries. All rights reserved. These materials may not be reproduced, displayed, distributed, nor may the information therein be used or disclosed in whole or in part, without the express written permission of Emily Yeung Schmidt.

DRAWN BY: EMILY YEUNG SCHMIDT

SCALE: N/A

DATE: 12.9.2022

DRAWING TITLE:

ARTIFACT SCHEDULE

DRAWING NO:

EX205



EX300 PLANS & SECTIONS



KEY PLAN

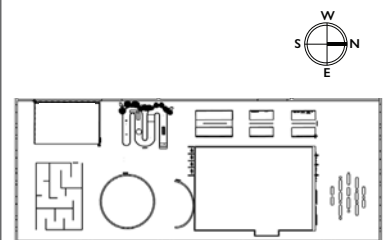

DISCLAIMER
This is an unpublished and proprietary work simultaneously protected under copyright, trade secret, and like laws of the United States and other countries. All rights reserved. These materials may not be reproduced, displayed, distributed, nor may the information therein be used or disclosed in whole or in part, without the express written permission of Emily Yeung Schmidt.

DRAWN BY: EMILY YEUNG SCHMIDT

SCALE: 1" = 30'

DATE: 12.9.2022

DRAWING TITLE:

CODED FLOOR PLAN

DRAWING NO:

EX301

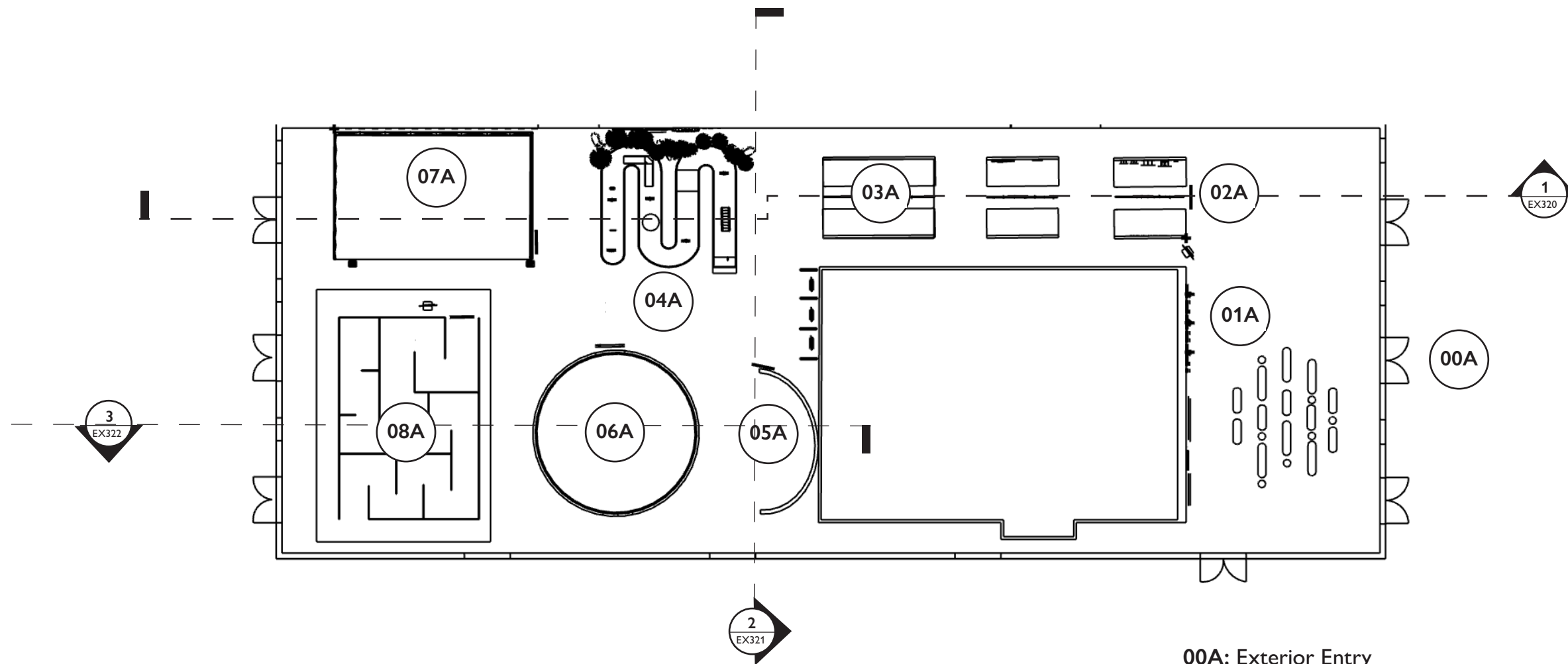

1 **CODE FLOOR PLAN**
SCALE 1" = 30'

- 00A:** Exterior Entry
- 01A:** Introduction
- 02A:** Corridors — Seeking Synchrony
- 03A:** Creating Happy Hormones
- 04A:** Take Your Course
- 05A:** Your Voice. My Voice.
- 06A:** Pathway To Inspire
- 07A:** Journey Together
- 08A:** Maze of Trust

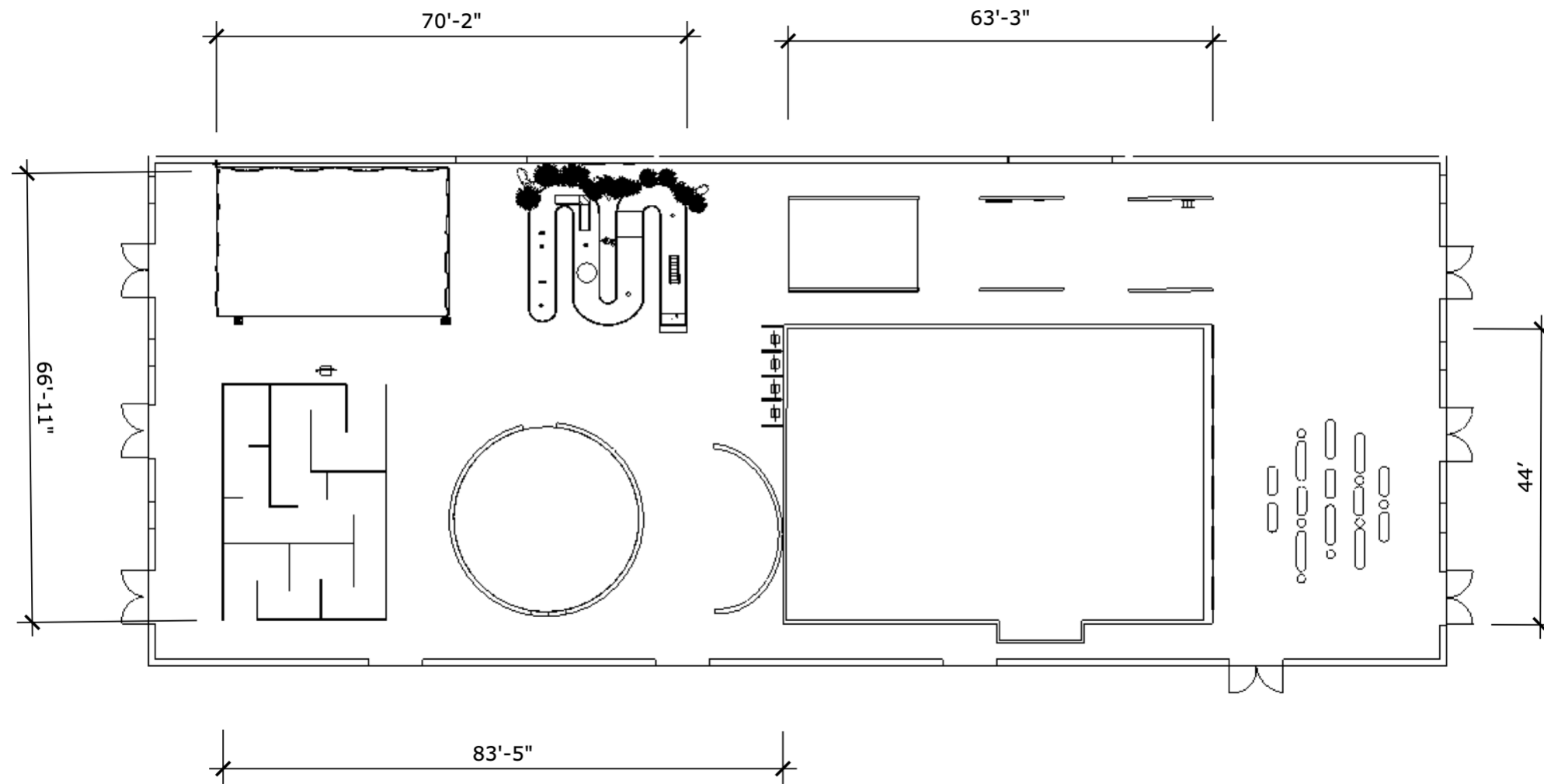

1 DIMENSION FLOOR PLAN
SCALE 1" = 30'

EMILY SCHMIDT
MA EXHIBITION & EXPERIENCE DESIGN

FASHION INSTITUTE OF TECHNOLOGY
School of Graduate Studies
272 West 27th St
New York, NY 10011



ST. ANN'S WAREHOUSE
45 Water Street
Brooklyn, NY 11201

CLIENT
GALLUP®

KEY PLAN

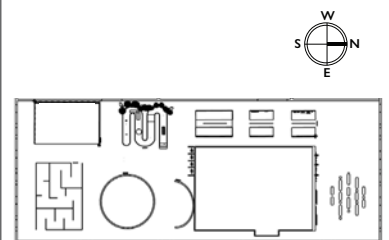

DISCLAIMER
This is an unpublished and proprietary work simultaneously protected under copyright, trade secret, and like laws of the United States and other countries. All rights reserved. These materials may not be reproduced, displayed, distributed, nor may the information therein be used or disclosed in whole or in part, without the express written permission of Emily Yeung Schmidt.

DRAWN BY: EMILY YEUNG SCHMIDT

SCALE: 1" = 30'

DATE: 12.9.2022

DRAWING TITLE:
DIMENSION FLOOR PLAN

DRAWING NO:

EX302

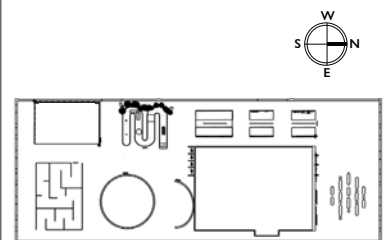

DISCLAIMER
This is an unpublished and proprietary work simultaneously protected under copyright, trade secret, and like laws of the United States and other countries. All rights reserved. These materials may not be reproduced, displayed, distributed, nor may the information therein be used or disclosed in whole or in part, without the express written permission of Emily Yeung Schmidt.

DRAWN BY: EMILY YEUNG SCHMIDT

SCALE: 1" = 30'

DATE: 12.9.2022

DRAWING TITLE:

DETAIL DIMENSION FLOOR PLAN

DRAWING NO:

EX303

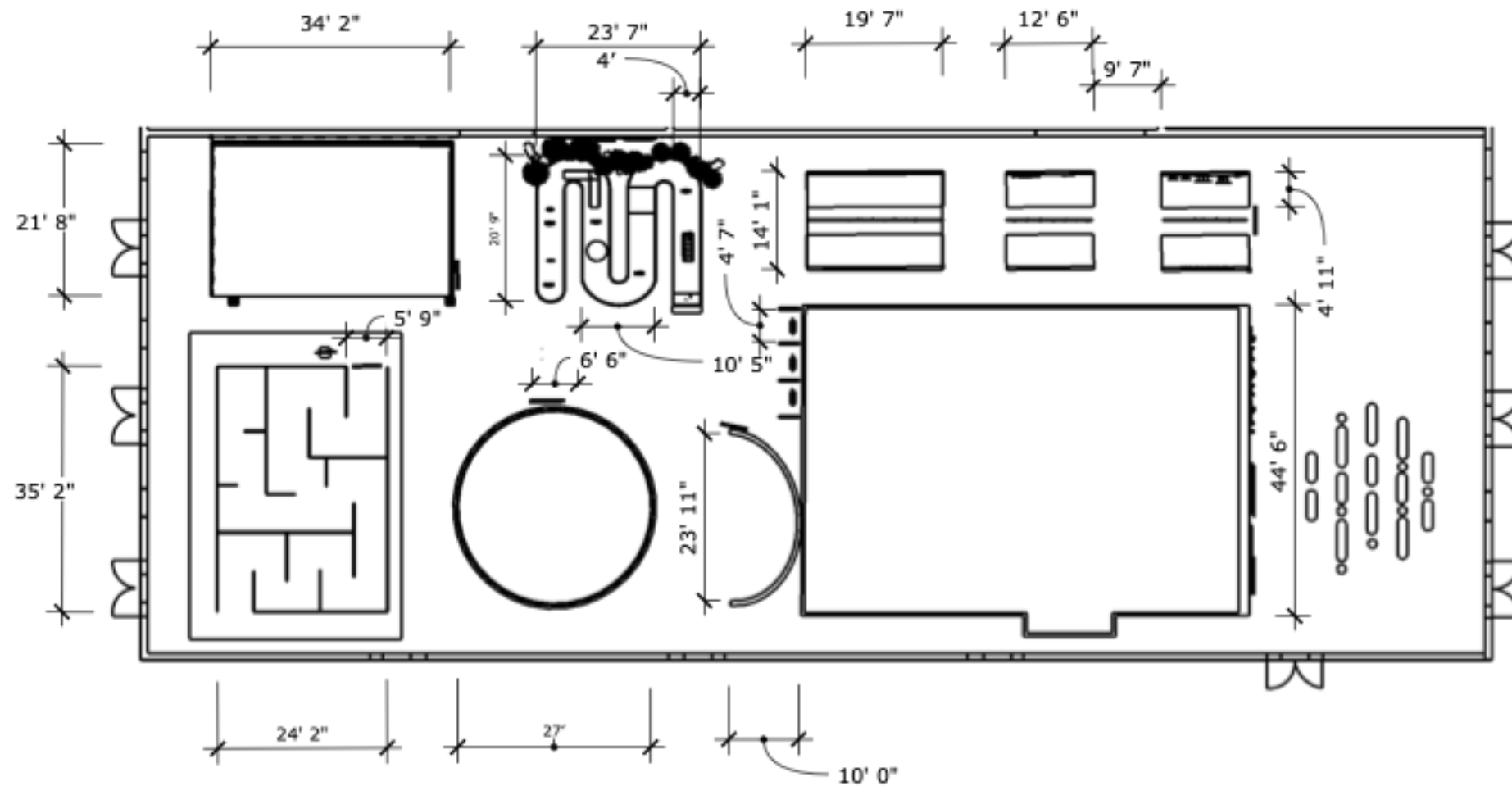

1 DETAIL DIMENSION FLOOR PLAN
1" = 30'



ST. ANN'S WAREHOUSE
45 Water Street
Brooklyn, NY 11201

CLIENT
GALLUP®

KEY PLAN

DISCLAIMER
This is an unpublished and proprietary work simultaneously protected under copyright, trade secret, and like laws of the United States and other countries. All rights reserved. These materials may not be reproduced, displayed, distributed, nor may the information therein be used or disclosed in whole or in part, without the express written permission of Emily Yeung Schmidt.

DRAWN BY: EMILY YEUNG SCHMIDT

SCALE: N/A

DATE: 12.9.2022

DRAWING TITLE:

GRAPHIC LOCATION PLAN (EXTERIOR)

DRAWING NO:

EX304

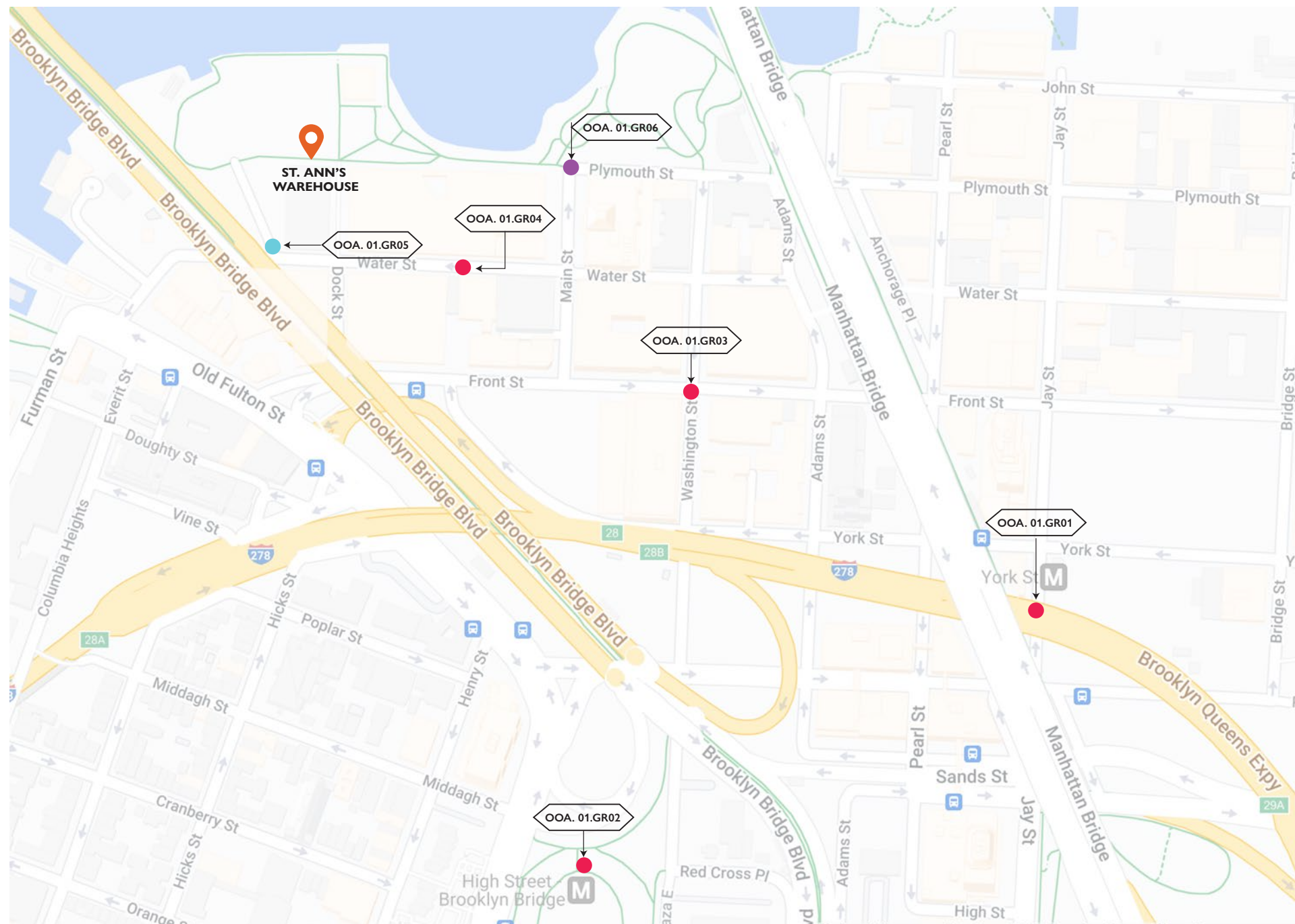

- Wayfinding
- Banner
- Mural

1 GRAPHIC LOCATION PLAN (EXTERIOR)
NOT IN SCALE



KEY PLAN

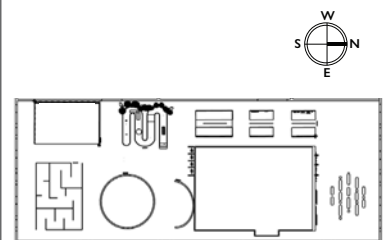

DISCLAIMER
This is an unpublished and proprietary work simultaneously protected under copyright, trade secret, and like laws of the United States and other countries. All rights reserved. These materials may not be reproduced, displayed, distributed, nor may the information therein be used or disclosed in whole or in part, without the express written permission of Emily Yeung Schmidt.

DRAWN BY: EMILY YEUNG SCHMIDT

SCALE: 1" = 30'

DATE: 12.9.2022

DRAWING TITLE:
GRAPHIC LOCATION PLAN (INTERIOR)

DRAWING NO:

EX305

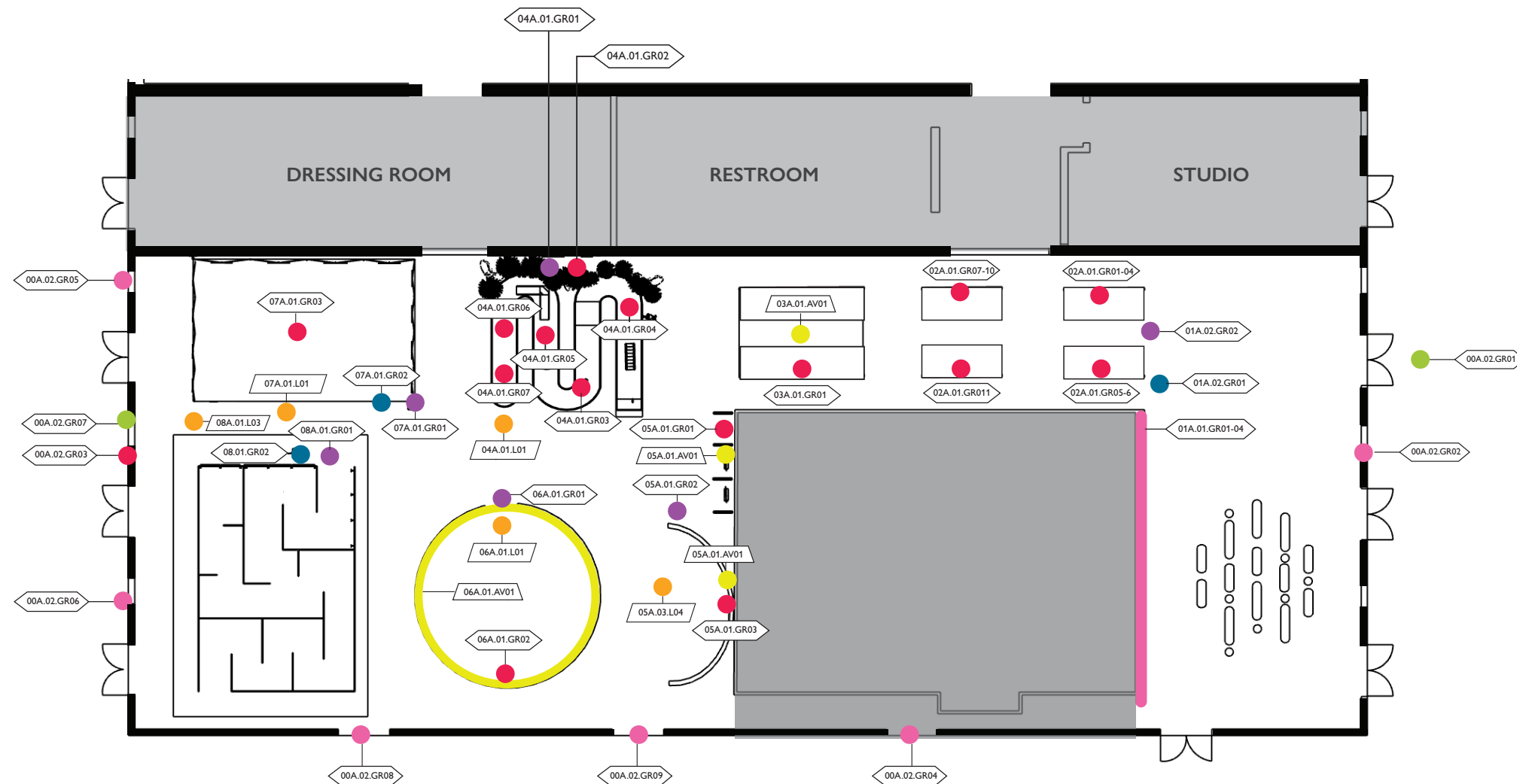

- KEY PLAN**
- Introduction
 - Area Graphics
 - Content Graphics
 - Directives
 - Digital Media
 - Labels
 - Banner
 - Gobo Projectors Graphic
 - Mural

1 GRAPHIC LOCATION PLAN (INTERIOR)
SCALE 1" = 30'



KEY PLAN

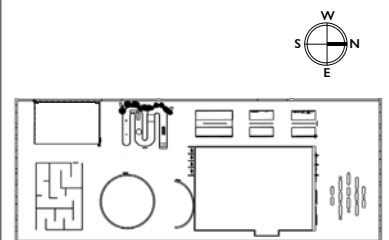

DISCLAIMER
This is an unpublished and proprietary work simultaneously protected under copyright, trade secret, and like laws of the United States and other countries. All rights reserved. These materials may not be reproduced, displayed, distributed, nor may the information therein be used or disclosed in whole or in part, without the express written permission of Emily Yeung Schmidt.

DRAWN BY: EMILY YEUNG SCHMIDT

SCALE: 1" = 30'

DATE: 12.9.2022

DRAWING TITLE:
MATERIAL PLAN

DRAWING NO:

EX306

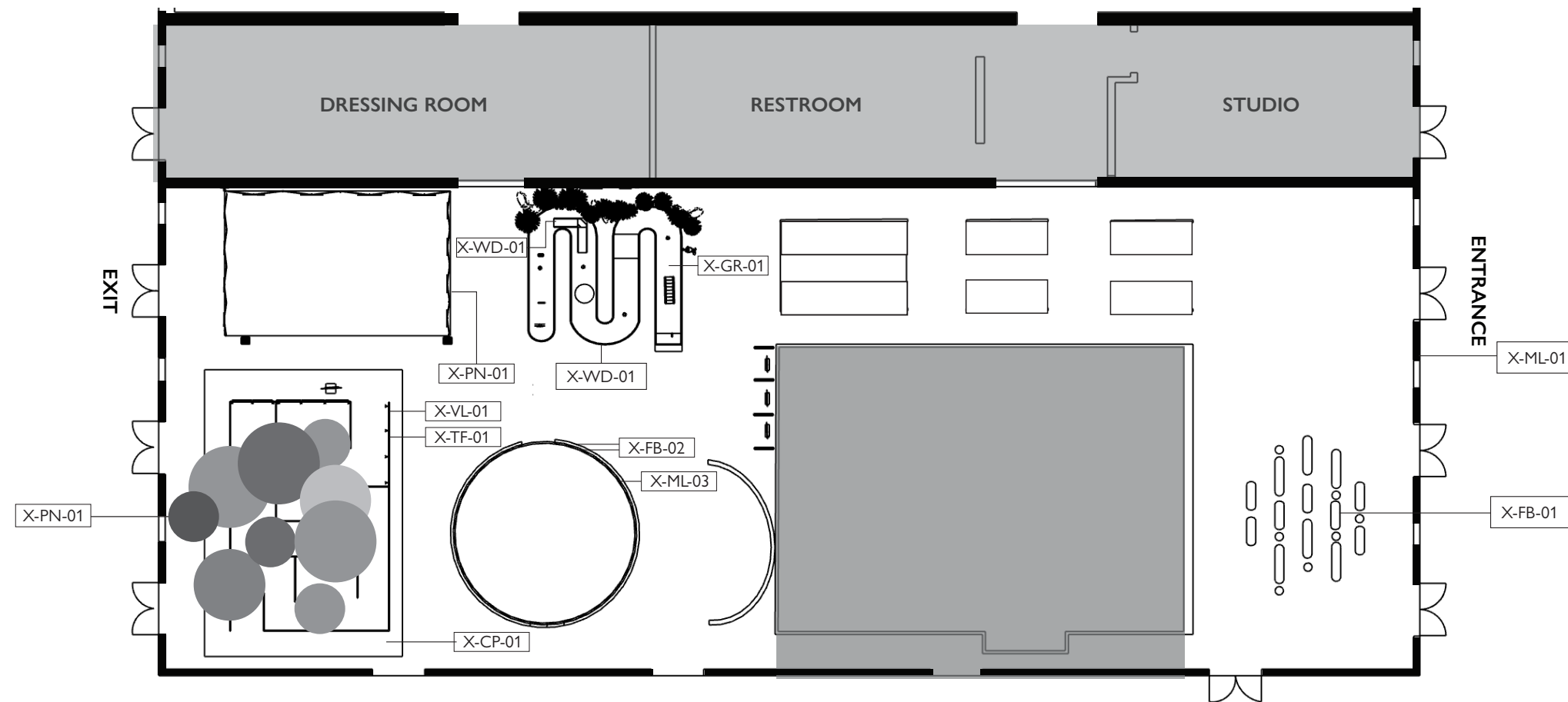

1 MATERIAL PLAN
SCALE 1" = 30'



KEY PLAN

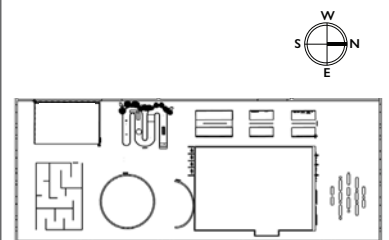

DISCLAIMER
This is an unpublished and proprietary work simultaneously protected under copyright, trade secret, and like laws of the United States and other countries. All rights reserved. These materials may not be reproduced, displayed, distributed, nor may the information therein be used or disclosed in whole or in part, without the express written permission of Emily Yeung Schmidt.

DRAWN BY: EMILY YEUNG SCHMIDT

SCALE: 1" = 30'

DATE: 12.9.2022

DRAWING TITLE:
LIGHTING PLAN

DRAWING NO:

EX307

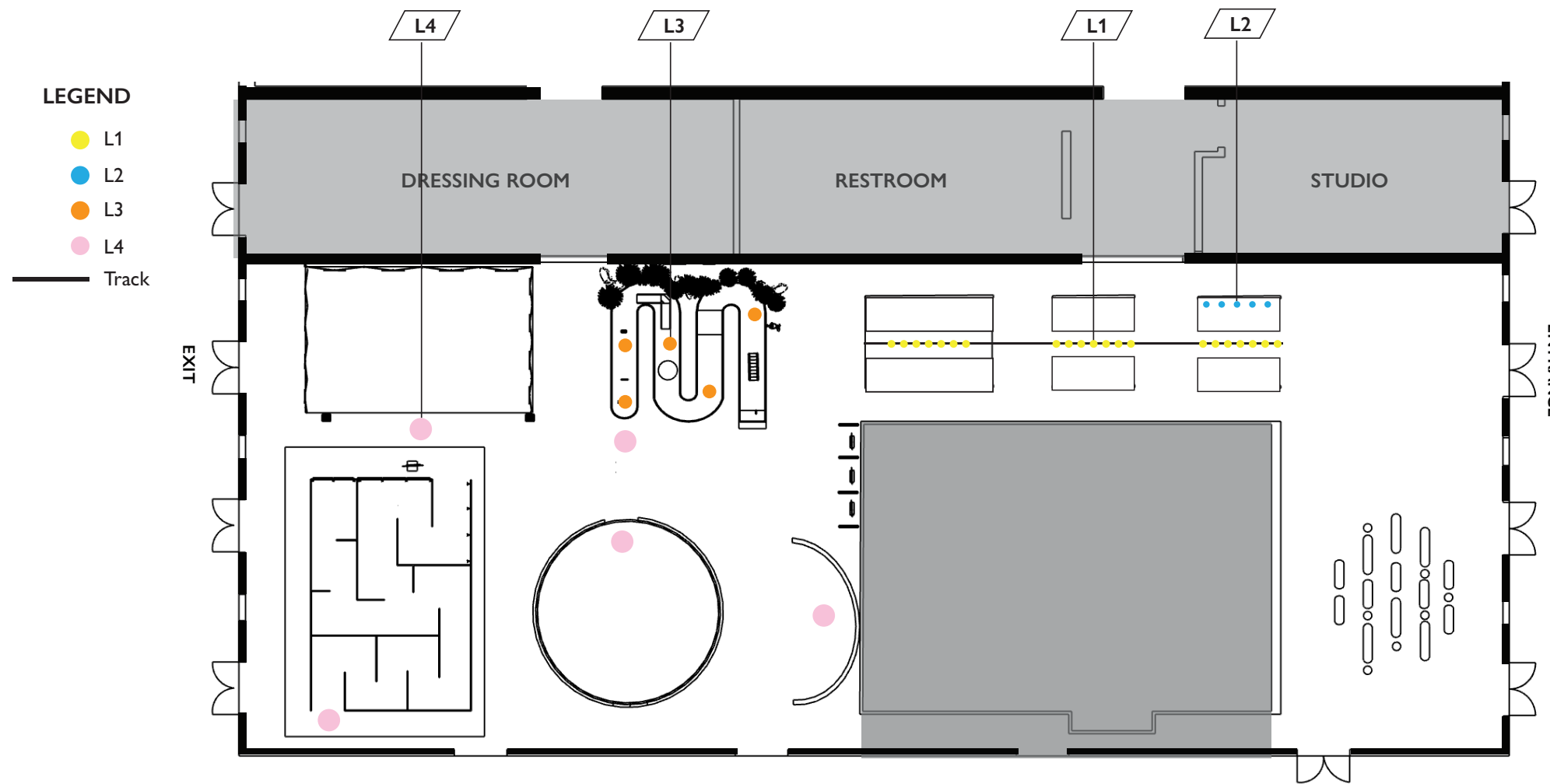

- LEGEND**
- L1
 - L2
 - L3
 - L4
 - Track

1 LIGHTING PLAN
SCALE 1" = 30'

EMILY SCHMIDT
MA EXHIBITION & EXPERIENCE DESIGN

FASHION INSTITUTE OF TECHNOLOGY
School of Graduate Studies
272 West 27th St
New York, NY 10011



ST. ANN'S WAREHOUSE
45 Water Street
Brooklyn, NY 11201

CLIENT
GALLUP®

KEY PLAN

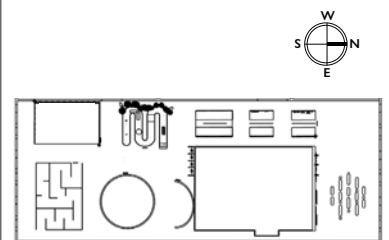

DISCLAIMER
This is an unpublished and proprietary work simultaneously protected under copyright, trade secret, and like laws of the United States and other countries. All rights reserved. These materials may not be reproduced, displayed, distributed, nor may the information therein be used or disclosed in whole or in part, without the express written permission of Emily Yeung Schmidt.

DRAWN BY: EMILY YEUNG SCHMIDT

SCALE: 1" = 30'

DATE: 12.9.2022

DRAWING TITLE:
ARTIFACT PLAN

DRAWING NO:

EX308

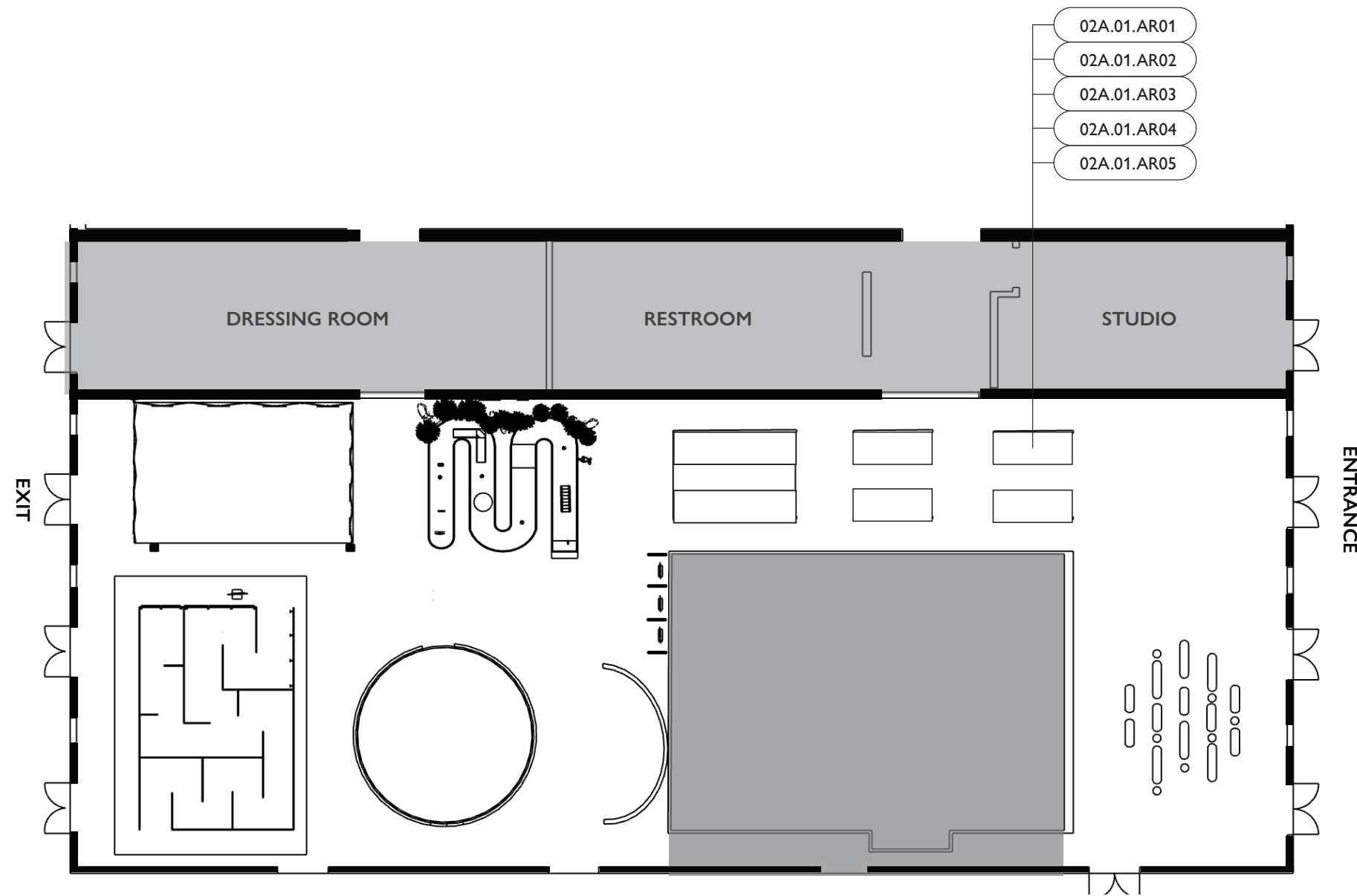

1 ARTIFACT PLAN
SCALE 1" = 30'

EMILY SCHMIDT
MA EXHIBITION & EXPERIENCE DESIGN

FASHION INSTITUTE OF TECHNOLOGY
School of Graduate Studies
272 West 27th St
New York, NY 10011



ST. ANN'S WAREHOUSE
45 Water Street
Brooklyn, NY 11201

CLIENT
GALLUP®

KEY PLAN

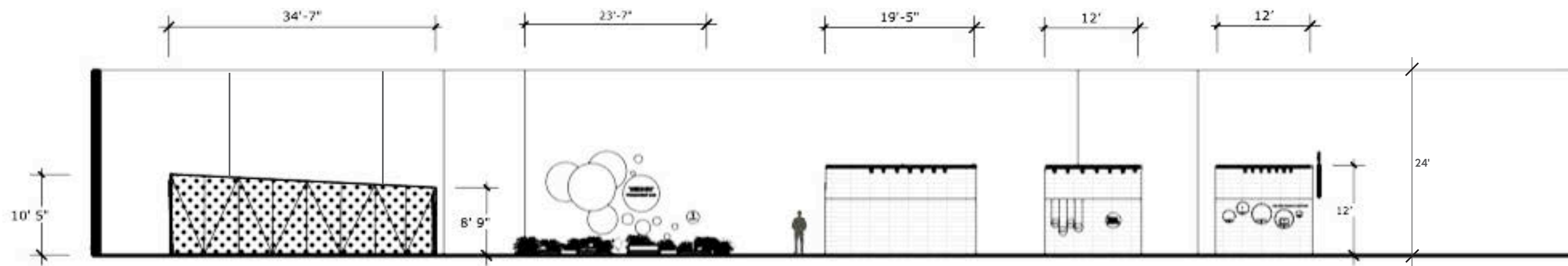
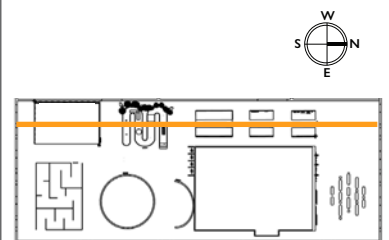

1 SECTION ELEVATION 1
SCALE: 1" = 20'

DISCLAIMER
This is an unpublished and proprietary work simultaneously protected under copyright, trade secret, and like laws of the United States and other countries. All rights reserved. These materials may not be reproduced, displayed, distributed, nor may the information therein be used or disclosed in whole or in part, without the express written permission of Emily Yeung Schmidt.

DRAWN BY: EMILY YEUNG SCHMIDT

SCALE: 1" = 20'

DATE: 12.9.2022

DRAWING TITLE:

SECTION ELEVATION 1

DRAWING NO:

EX320

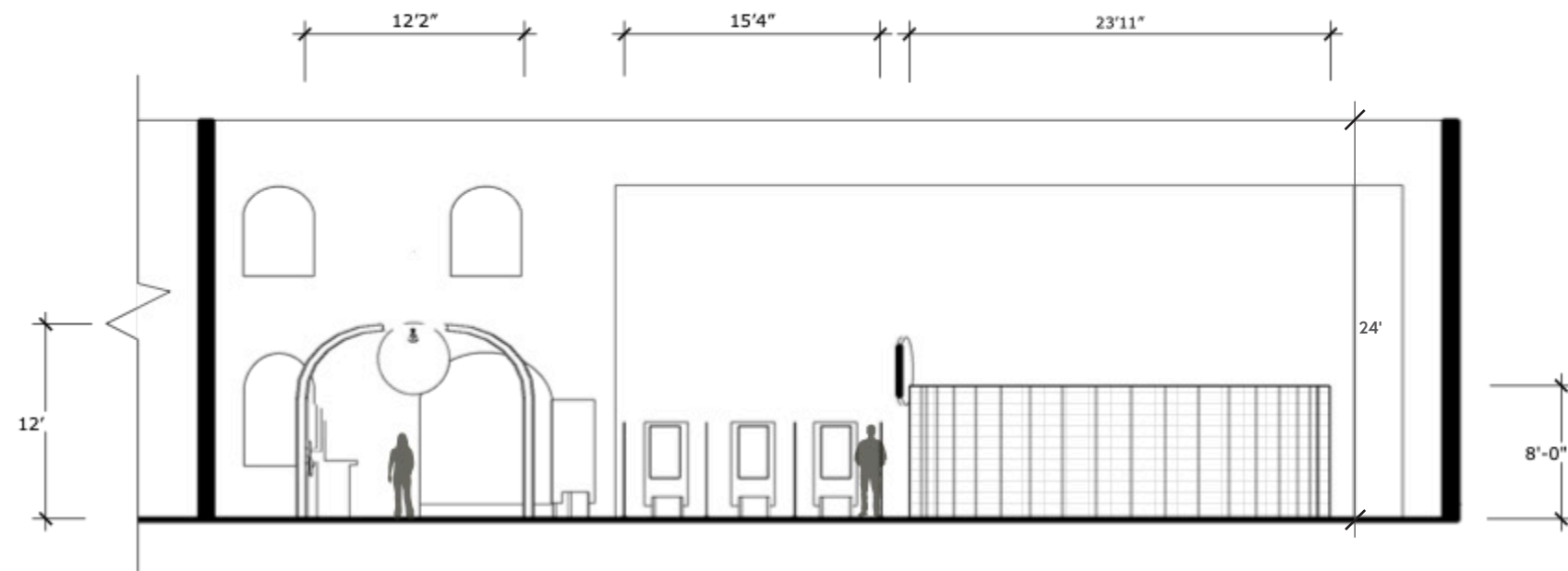

2 SECTION ELEVATION 2
SCALE: 3/32" = 1'-0"

EMILY SCHMIDT
MA EXHIBITION & EXPERIENCE DESIGN

FASHION INSTITUTE OF TECHNOLOGY
School of Graduate Studies
272 West 27th St
New York, NY 10011



ST. ANN'S WAREHOUSE
45 Water Street
Brooklyn, NY 11201

CLIENT

GALLUP®

KEY PLAN

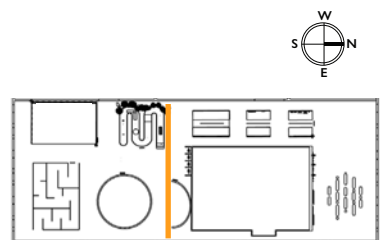

DISCLAIMER

This is an unpublished and proprietary work simultaneously protected under copyright, trade secret, and like laws of the United States and other countries. All rights reserved. These materials may not be reproduced, displayed, distributed, nor may the information therein be used or disclosed in whole or in part, without the express written permission of Emily Yeung Schmidt.

DRAWN BY: EMILY YEUNG SCHMIDT

SCALE: 3/32" = 1'-0"

DATE: 12.9.2022

DRAWING TITLE:

**SECTION
ELEVATION 2**

DRAWING NO:

EX321

EMILY SCHMIDT
MA EXHIBITION & EXPERIENCE DESIGN

FASHION INSTITUTE OF TECHNOLOGY
School of Graduate Studies
272 West 27th St
New York, NY 10011



ST. ANN'S WAREHOUSE
45 Water Street
Brooklyn, NY 11201

CLIENT

GALLUP®

KEY PLAN

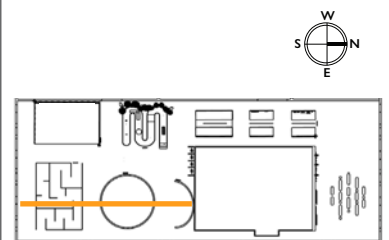

DISCLAIMER

This is an unpublished and proprietary work simultaneously protected under copyright, trade secret, and like laws of the United States and other countries. All rights reserved. These materials may not be reproduced, displayed, distributed, nor may the information therein be used or disclosed in whole or in part, without the express written permission of Emily Yeung Schmidt.

DRAWN BY: EMILY YEUNG SCHMIDT

SCALE: 3/32" = 1'-0"

DATE: 12.9.2022

DRAWING TITLE:

**SECTION
ELEVATION 3**

DRAWING NO:

EX322

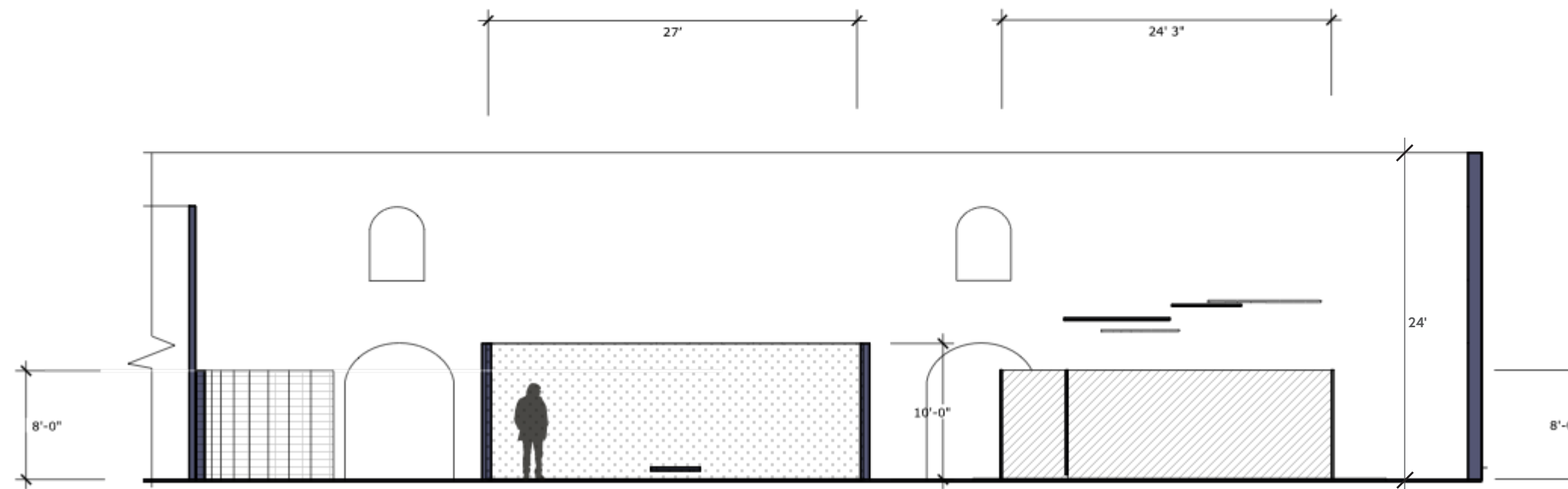

3 SECTION ELEVATION 3
SCALE: 3/32" = 1'-0"



EX400 **GRAPHIC SYSTEMS**

VISUAL COMMUNICATION

The graphic look and feel for In-Sync tells visitors a story — **the essentials of creating trust, collaboration, togetherness and happiness in the post-pandemic work culture. Lines represent pathways or challenges of unprecedented workplace environment after the pandemic. Dots connect pathways, creating the in-sync spirit. The halftone shading indicating a burst of joy, emerges when the happy hormones are created in our bodies. The colors are pulled from the brand identity which is vibrant, positive and cheerful. Translucent color overlaps black & white photos, which speaks to clear communication.**

In-Sync branding illustrates a sense of movement that embodies the human connection. Gill Sans Nova speaks harmony that pairs well with the logo and applies throughout the system. The In-Sync logo expresses joyfulness, connection and unity.

EMILY SCHMIDT
MA EXHIBITION & EXPERIENCE DESIGN

FASHION INSTITUTE OF TECHNOLOGY
School of Graduate Studies
272 West 27th St
New York, NY 10011



ST. ANN'S WAREHOUSE
45 Water Street
Brooklyn, NY 11201

CLIENT

GALLUP®

KEY PLAN

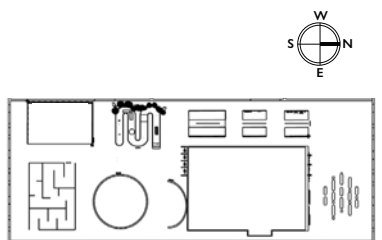

DISCLAIMER

This is an unpublished and proprietary work simultaneously protected under copyright, trade secret, and like laws of the United States and other countries. All rights reserved. These materials may not be reproduced, displayed, distributed, nor may the information therein be used or disclosed in whole or in part, without the express written permission of Emily Yeung Schmidt.

DRAWN BY: EMILY YEUNG SCHMIDT

SCALE:

DATE: 12.9.2022

DRAWING TITLE:

**VISUAL
COMMUNICATION**

DRAWING NO:

EX401

EMILY SCHMIDT
MA EXHIBITION & EXPERIENCE DESIGN

FASHION INSTITUTE OF TECHNOLOGY
School of Graduate Studies
272 West 27th St
New York, NY 10011

in-sync

ST. ANN'S WAREHOUSE
45 Water Street
Brooklyn, NY 11201

CLIENT
GALLUP®

KEY PLAN

DISCLAIMER
This is an unpublished and proprietary work simultaneously protected under copyright, trade secret, and like laws of the United States and other countries. All rights reserved. These materials may not be reproduced, displayed, distributed, nor may the information therein be used or disclosed in whole or in part, without the express written permission of Emily Yeung Schmidt.

DRAWN BY: EMILY YEUNG SCHMIDT

SCALE: N/A

DATE: 12.9.2022

DRAWING TITLE:

MOOD BOARDS

DRAWING NO:

EX402

GRAPHIC



Transparent



Pathways

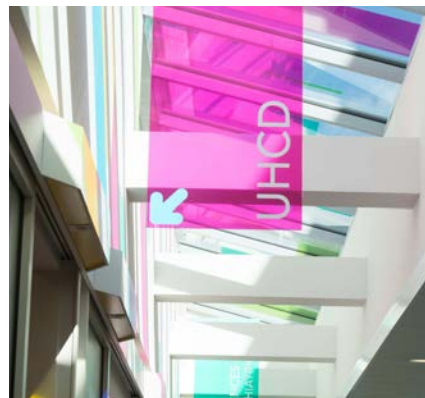

Layers



Direction



Connection

EXHIBIT





ST. ANN'S WAREHOUSE
45 Water Street
Brooklyn, NY 11201

CLIENT
GALLUP®

KEY PLAN

DISCLAIMER
This is an unpublished and proprietary work simultaneously protected under copyright, trade secret, and like laws of the United States and other countries. All rights reserved. These materials may not be reproduced, displayed, distributed, nor may the information therein be used or disclosed in whole or in part, without the express written permission of Emily Yeung Schmidt.

DRAWN BY: EMILY YEUNG SCHMIDT

SCALE: N/A

DATE: 12.9.2022

DRAWING TITLE:

CONCEPT SKETCHES

DRAWING NO:

EX403

in-sync

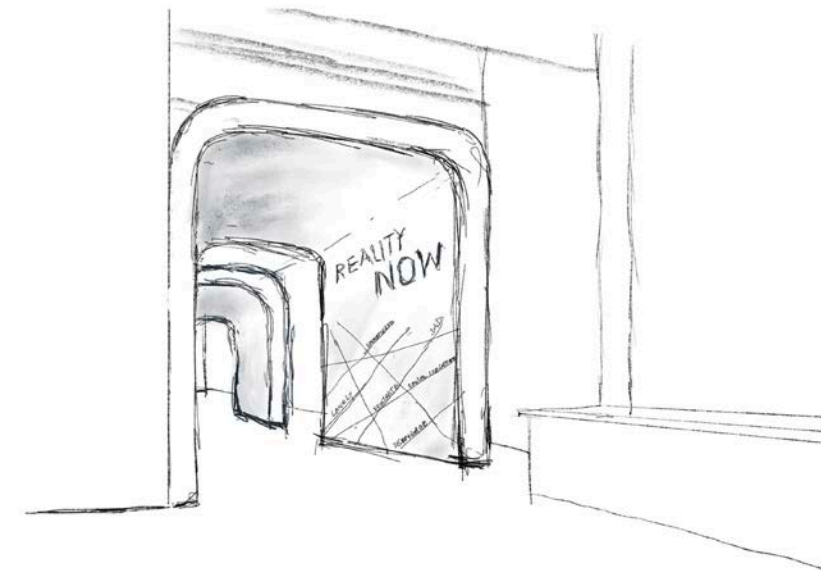
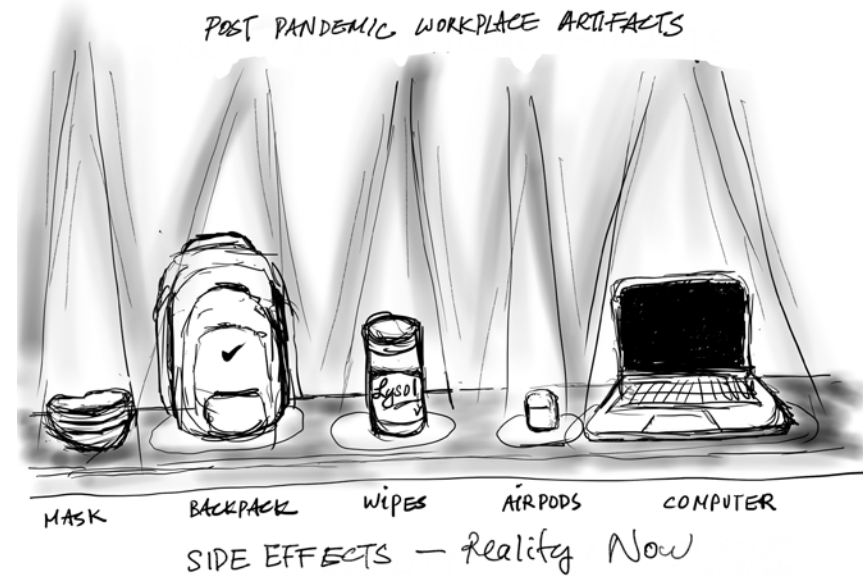

- SUPPORT EACH OTHER WHEN YOU ARE LOSS
 - CREATE OXYTOCIN (TRUST OR BE TRUSTED)
- CULTIVATING EMPATHY

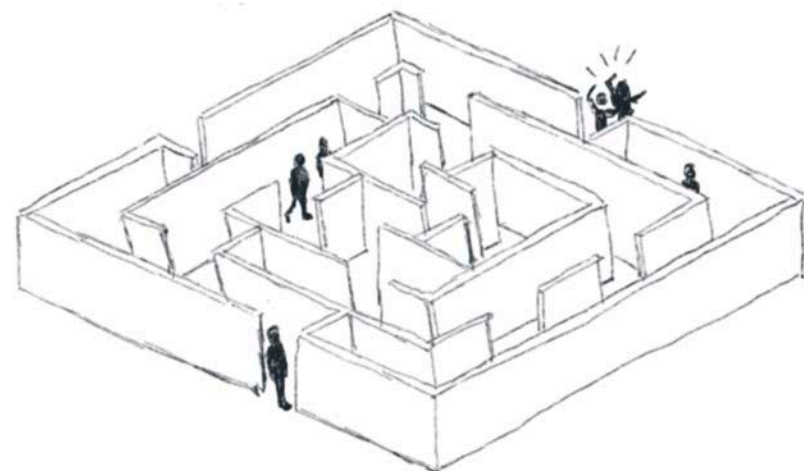

- WALL with different color with WORDS / GRAPHIC

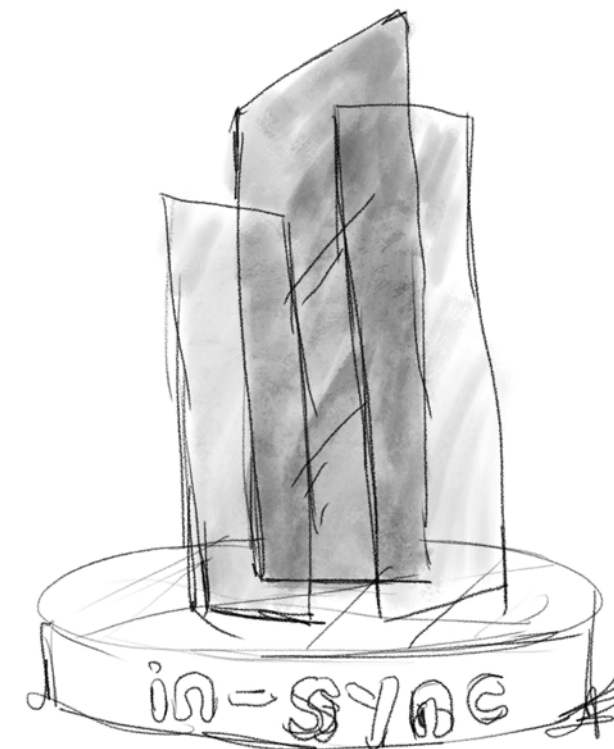
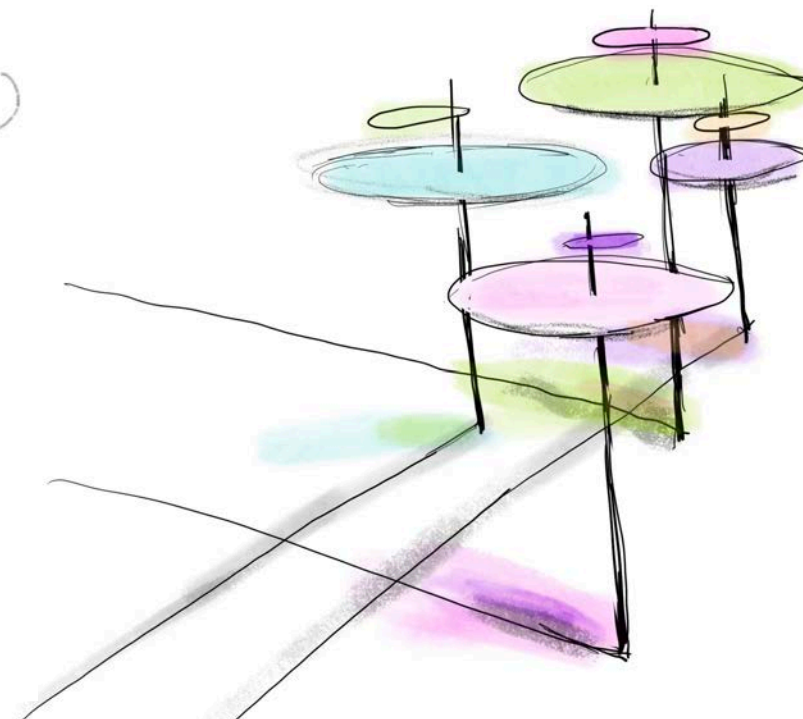

COLOR PALETTE

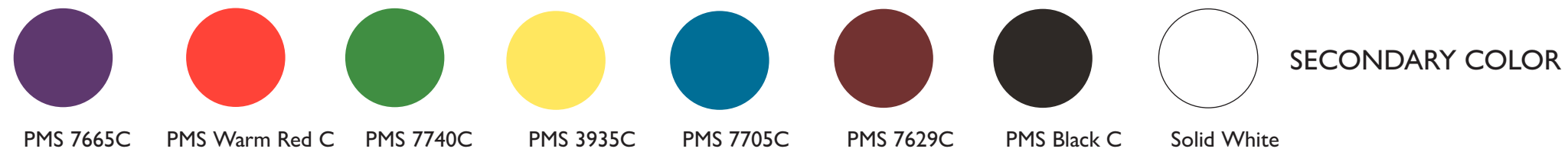
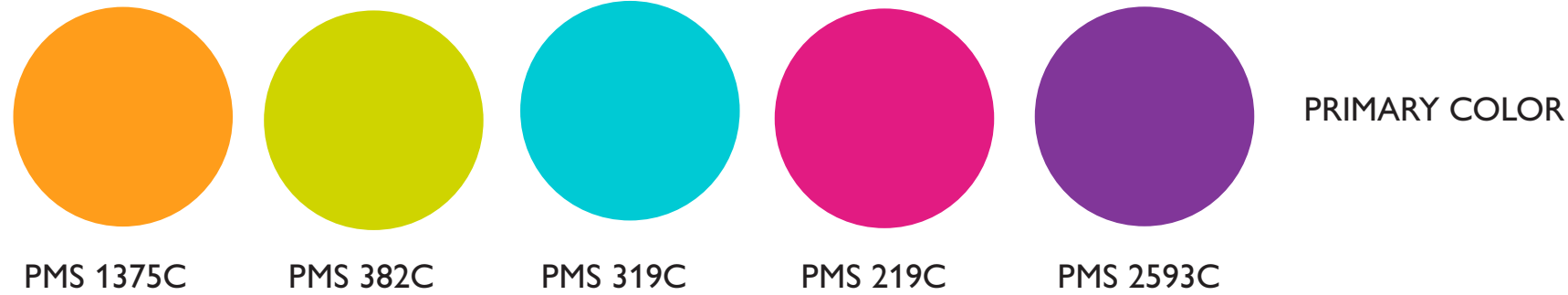

TYPE | GILL SANS NOVA

Gill Sans Nova | Book

ABCDEFGHIJKLMNOPQRSTUVWXYZ
abcdefghijklmnopqrstuvwxyz1234567890

Gill Sans Nova | Bold

ABCDEFGHIJKLMNOPQRSTUVWXYZ
abcdefghijklmnopqrstuvwxyz1234567890

EMILY SCHMIDT
MA EXHIBITION & EXPERIENCE DESIGN

FASHION INSTITUTE OF TECHNOLOGY
School of Graduate Studies
272 West 27th St
New York, NY 10011



ST. ANN'S WAREHOUSE
45 Water Street
Brooklyn, NY 11201

CLIENT
GALLUP®

KEY PLAN

DISCLAIMER
This is an unpublished and proprietary work simultaneously protected under copyright, trade secret, and like laws of the United States and other countries. All rights reserved. These materials may not be reproduced, displayed, distributed, nor may the information therein be used or disclosed in whole or in part, without the express written permission of Emily Yeung Schmidt.

DRAWN BY: EMILY YEUNG SCHMIDT

SCALE: N/A

DATE: 12.9.2022

DRAWING TITLE:

**BRAND COLOR &
TYPEFACE**

DRAWING NO:

EX404

BRAND IDENTITY

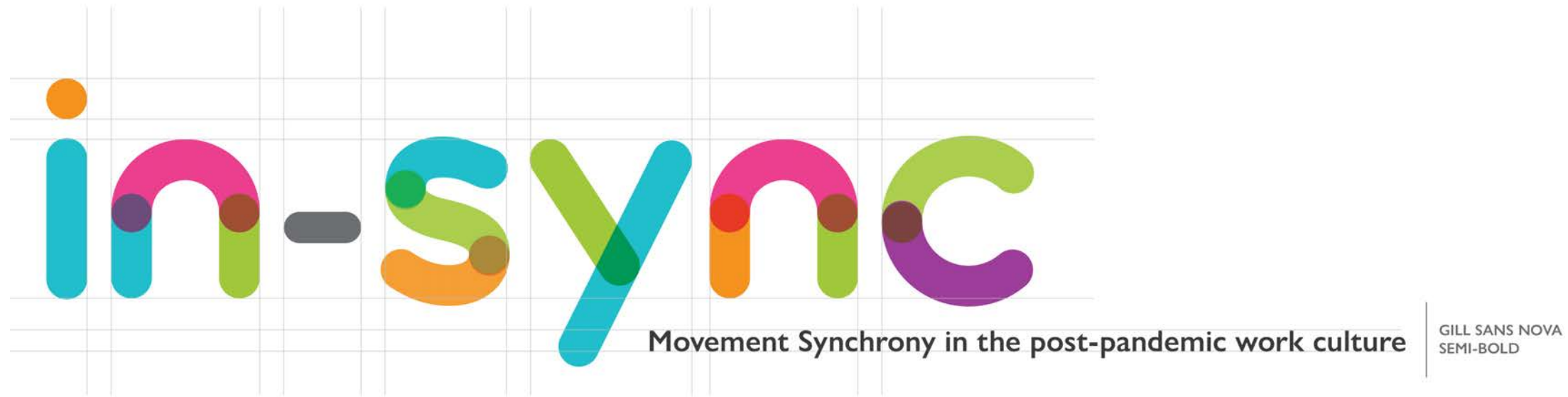

EMILY SCHMIDT
MA EXHIBITION & EXPERIENCE DESIGN

FASHION INSTITUTE OF TECHNOLOGY
School of Graduate Studies
272 West 27th St
New York, NY 10011



ST. ANN'S WAREHOUSE
45 Water Street
Brooklyn, NY 11201

CLIENT
GALLUP®

KEY PLAN

DISCLAIMER
This is an unpublished and proprietary work simultaneously protected under copyright, trade secret, and like laws of the United States and other countries. All rights reserved. These materials may not be reproduced, displayed, distributed, nor may the information therein be used or disclosed in whole or in part, without the express written permission of Emily Yeung Schmidt.

DRAWN BY: EMILY YEUNG SCHMIDT

SCALE: N/A

DATE: 12.9.2022

DRAWING TITLE:

BRAND IDENTITY

DRAWING NO:

EX405

GRAPHIC LOOK & FEEL



KEY PATTERNS

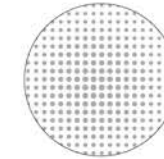

Halftone

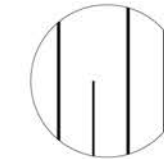

Lines

EMILY SCHMIDT

MA EXHIBITION & EXPERIENCE DESIGN

FASHION INSTITUTE OF TECHNOLOGY
School of Graduate Studies
272 West 27th St
New York, NY 10011

in-sync

ST. ANN'S WAREHOUSE
45 Water Street
Brooklyn, NY 11201

CLIENT

GALLUP®

KEY PLAN

DISCLAIMER

This is an unpublished and proprietary work simultaneously protected under copyright, trade secret, and like laws of the United States and other countries. All rights reserved. These materials may not be reproduced, displayed, distributed, nor may the information therein be used or disclosed in whole or in part, without the express written permission of Emily Yeung Schmidt.

DRAWN BY: EMILY YEUNG SCHMIDT

SCALE: N/A

DATE: 12.9.2022

DRAWING TITLE:

GRAPHIC LOOK & FEEL

DRAWING NO:

EX406

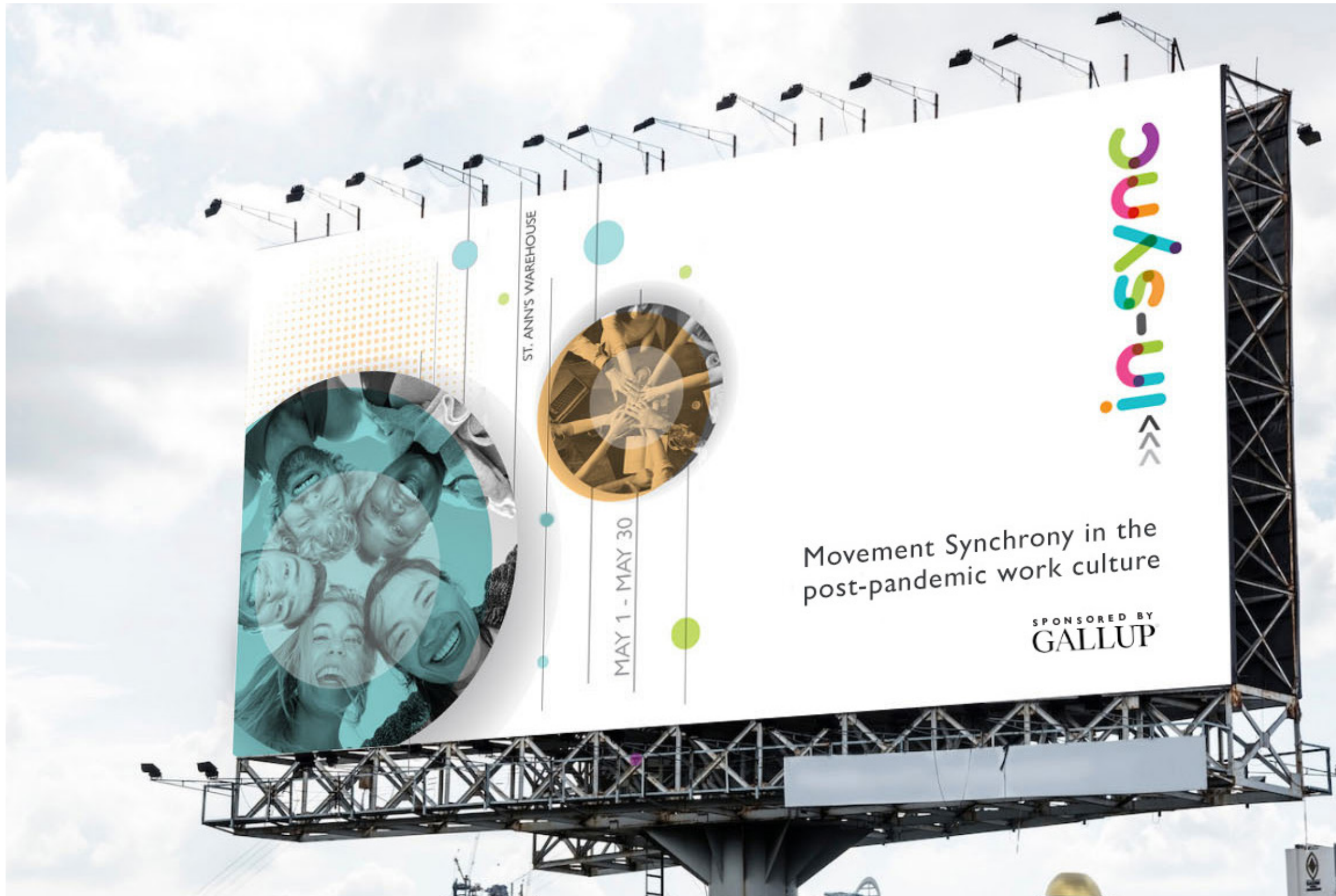

EMILY SCHMIDT
MA EXHIBITION & EXPERIENCE DESIGN

FASHION INSTITUTE OF TECHNOLOGY
School of Graduate Studies
272 West 27th St
New York, NY 10011

in-sync

ST. ANN'S WAREHOUSE
45 Water Street
Brooklyn, NY 11201

CLIENT
GALLUP®

KEY PLAN

DISCLAIMER
This is an unpublished and proprietary work simultaneously protected under copyright, trade secret, and like laws of the United States and other countries. All rights reserved. These materials may not be reproduced, displayed, distributed, nor may the information therein be used or disclosed in whole or in part, without the express written permission of Emily Yeung Schmidt.

DRAWN BY: EMILY YEUNG SCHMIDT

SCALE: N/A

DATE: 12.9.2022

DRAWING TITLE:

**ADVERTISING
COMPONENTS 1**

DRAWING NO:

EX407



EMILY SCHMIDT
MA EXHIBITION & EXPERIENCE DESIGN

FASHION INSTITUTE OF TECHNOLOGY
School of Graduate Studies
272 West 27th St
New York, NY 10011

in-sync

ST. ANN'S WAREHOUSE
45 Water Street
Brooklyn, NY 11201

CLIENT
GALLUP®

KEY PLAN

DISCLAIMER
This is an unpublished and proprietary work simultaneously protected under copyright, trade secret, and like laws of the United States and other countries. All rights reserved. These materials may not be reproduced, displayed, distributed, nor may the information therein be used or disclosed in whole or in part, without the express written permission of Emily Yeung Schmidt.

DRAWN BY: EMILY YEUNG SCHMIDT

SCALE: N/A

DATE: 12.9.2022

DRAWING TITLE:

**ADVERTISING
COMPONENTS 2**

DRAWING NO:

EX408

MAY 1 — MAY 30

ST. ANN'S WAREHOUSE

in-sync

Movement Synchrony
in the post-pandemic
work culture

SPONSORED BY
GALLUP

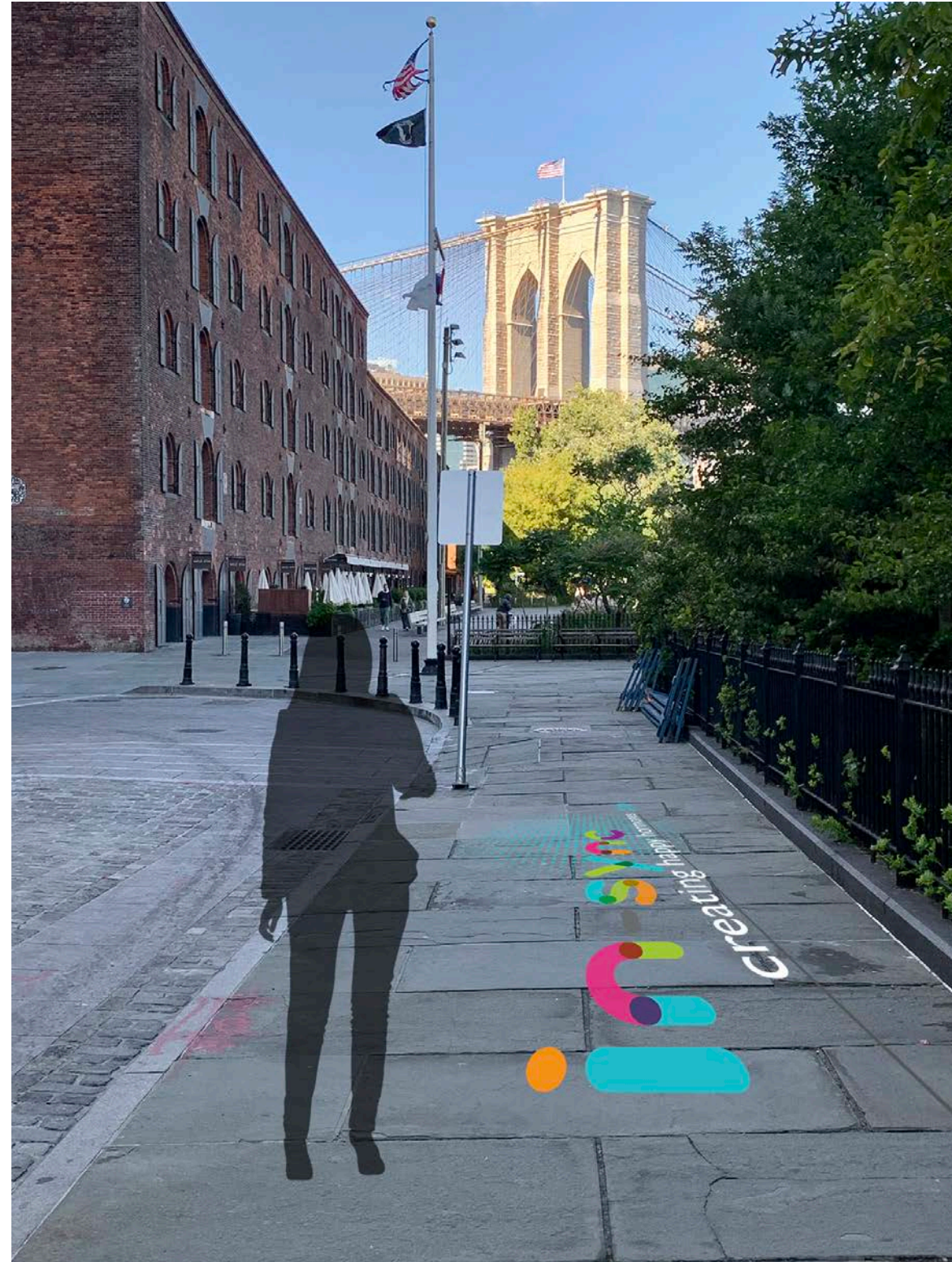

EMILY SCHMIDT
MA EXHIBITION & EXPERIENCE DESIGN

FASHION INSTITUTE OF TECHNOLOGY
School of Graduate Studies
272 West 27th St
New York, NY 10011

in-sync

ST. ANN'S WAREHOUSE
45 Water Street
Brooklyn, NY 11201

CLIENT
GALLUP

KEY PLAN

DISCLAIMER
This is an unpublished and proprietary work simultaneously protected under copyright, trade secret, and like laws of the United States and other countries. All rights reserved. These materials may not be reproduced, displayed, distributed, nor may the information therein be used or disclosed in whole or in part, without the express written permission of Emily Yeung Schmidt.

DRAWN BY: EMILY YEUNG SCHMIDT

SCALE: N/A

DATE: 12.9.2022

DRAWING TITLE:
WAYFINDING APPLICATIONS 1

DRAWING NO:

EX409



WATER STREET_DAYTIME



WATER STREET_NIGHTTIME

EMILY SCHMIDT
MA EXHIBITION & EXPERIENCE DESIGN

FASHION INSTITUTE OF TECHNOLOGY
School of Graduate Studies
272 West 27th St
New York, NY 10011

in-sync

ST. ANN'S WAREHOUSE
45 Water Street
Brooklyn, NY 11201

CLIENT
GALLUP®

KEY PLAN

DISCLAIMER
This is an unpublished and proprietary work simultaneously protected under copyright, trade secret, and like laws of the United States and other countries. All rights reserved. These materials may not be reproduced, displayed, distributed, nor may the information therein be used or disclosed in whole or in part, without the express written permission of Emily Yeung Schmidt.

DRAWN BY: EMILY YEUNG SCHMIDT

SCALE: N/A

DATE: 12.9.2022

DRAWING TITLE:
WAYFINDING APPLICATION 2

DRAWING NO:

EX410



EMILY SCHMIDT

MA EXHIBITION & EXPERIENCE DESIGN

FASHION INSTITUTE OF TECHNOLOGY
 School of Graduate Studies
 272 West 27th St
 New York, NY 10011



ST. ANN'S WAREHOUSE
 45 Water Street
 Brooklyn, NY 11201

CLIENT



KEY PLAN

DISCLAIMER

This is an unpublished and proprietary work simultaneously protected under copyright, trade secret, and like laws of the United States and other countries. All rights reserved. These materials may not be reproduced, displayed, distributed, nor may the information therein be used or disclosed in whole or in part, without the express written permission of Emily Yeung Schmidt.

DRAWN BY: EMILY YEUNG SCHMIDT

SCALE: N/A

DATE: 12.9.2022

DRAWING TITLE:

WAYFINDING APPLICATIONS 3

DRAWING NO:

EX411



T-SHIRT — FACILITATOR



GIVEAWAYS

EMILY SCHMIDT

MA EXHIBITION & EXPERIENCE DESIGN

FASHION INSTITUTE OF TECHNOLOGY
School of Graduate Studies
272 West 27th St
New York, NY 10011



ST. ANN'S WAREHOUSE
45 Water Street
Brooklyn, NY 11201

CLIENT

GALLUP®

KEY PLAN

DISCLAIMER

This is an unpublished and proprietary work simultaneously protected under copyright, trade secret, and like laws of the United States and other countries. All rights reserved. These materials may not be reproduced, displayed, distributed, nor may the information therein be used or disclosed in whole or in part, without the express written permission of Emily Yeung Schmidt.

DRAWN BY: EMILY YEUNG SCHMIDT

SCALE: N/A

DATE: 12.9.2022

DRAWING TITLE:

COLLATERAL

DRAWING NO:

EX412

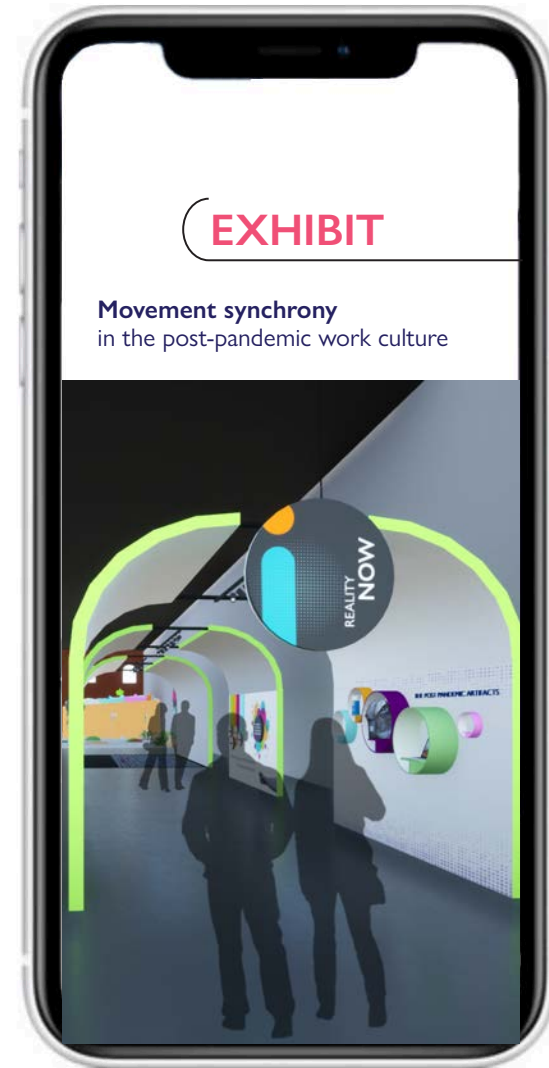
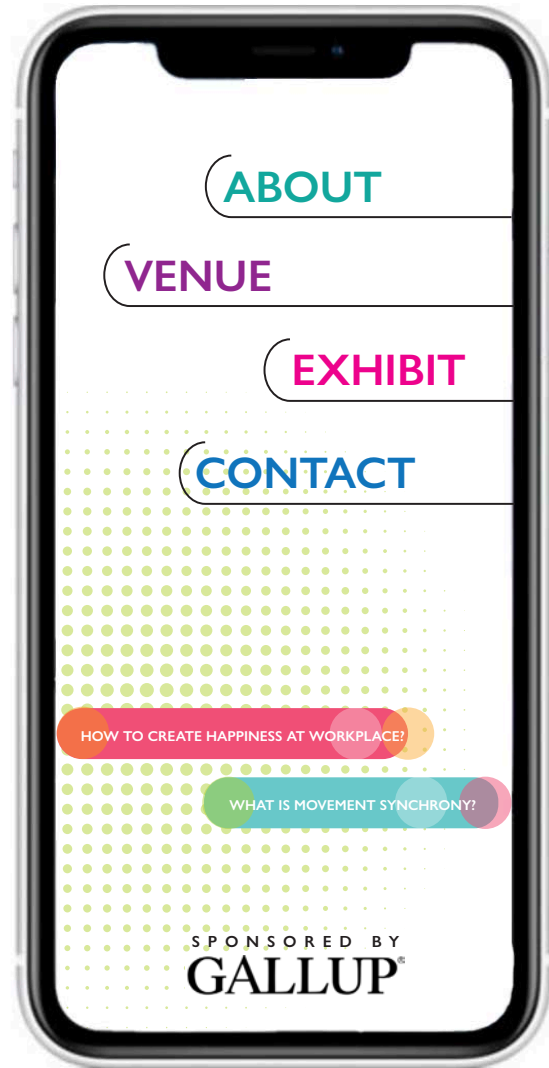

EMILY SCHMIDT
MA EXHIBITION & EXPERIENCE DESIGN

FASHION INSTITUTE OF TECHNOLOGY
School of Graduate Studies
272 West 27th St
New York, NY 10011



ST. ANN'S WAREHOUSE
45 Water Street
Brooklyn, NY 11201

CLIENT
GALLUP®

KEY PLAN

DISCLAIMER
This is an unpublished and proprietary work simultaneously protected under copyright, trade secret, and like laws of the United States and other countries. All rights reserved. These materials may not be reproduced, displayed, distributed, nor may the information therein be used or disclosed in whole or in part, without the express written permission of Emily Yeung Schmidt.

DRAWN BY: EMILY YEUNG SCHMIDT

SCALE: N/A

DATE: 12.9.2022

DRAWING TITLE:

DIGITAL PLATFORM — WEBSITE/APP

DRAWING NO:

EX413

GRAPHIC FAMILY

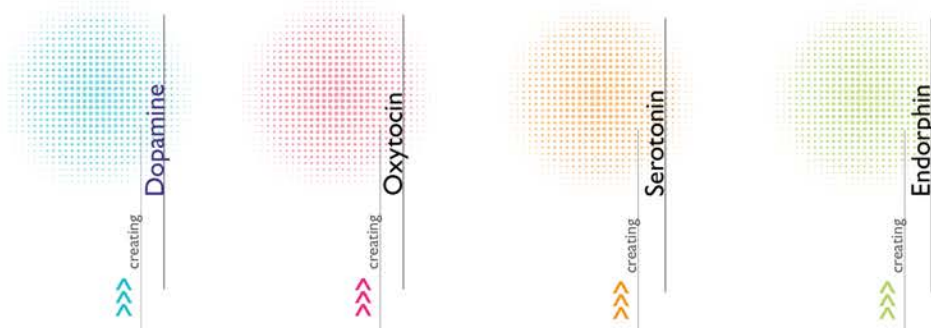
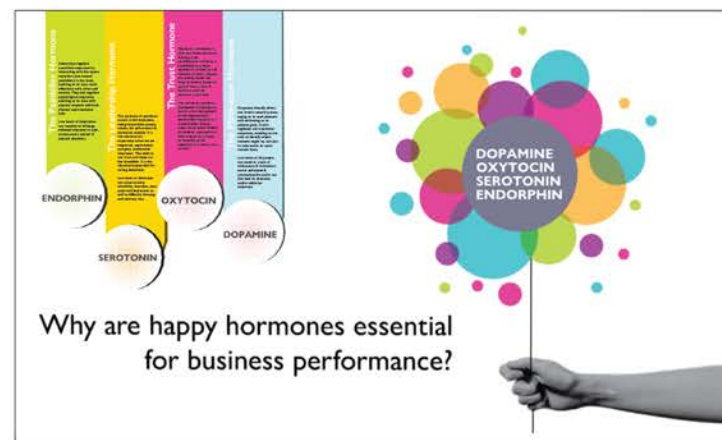
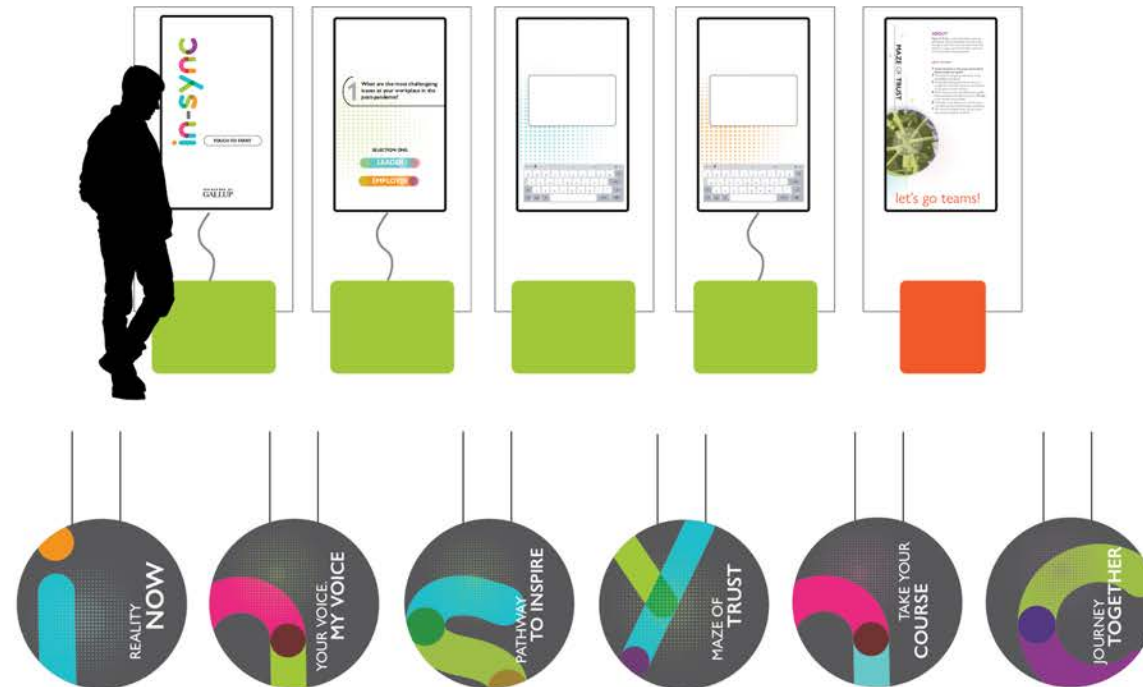

EMILY SCHMIDT
MA EXHIBITION & EXPERIENCE DESIGN

FASHION INSTITUTE OF TECHNOLOGY
School of Graduate Studies
272 West 27th St
New York, NY 10011

in-sync

ST. ANN'S WAREHOUSE
45 Water Street
Brooklyn, NY 11201

CLIENT
GALLUP®

KEY PLAN

DISCLAIMER
This is an unpublished and proprietary work simultaneously protected under copyright, trade secret, and like laws of the United States and other countries. All rights reserved. These materials may not be reproduced, displayed, distributed, nor may the information therein be used or disclosed in whole or in part, without the express written permission of Emily Yeung Schmidt.

DRAWN BY: EMILY YEUNG SCHMIDT

SCALE: N/A

DATE: 12.9.2022

DRAWING TITLE:
GRAPHIC FAMILY

DRAWING NO:

EX414

A decorative horizontal bar with a teal background. On the left side, there are three overlapping circles: a pink one, a purple one, and a light blue one. On the right side, there are two overlapping circles: a green one and a light green one. The text "EX500 DETAILS" is centered on the teal bar.

EX500 DETAILS

EMILY SCHMIDT
MA EXHIBITION & EXPERIENCE DESIGN

FASHION INSTITUTE OF TECHNOLOGY
School of Graduate Studies
272 West 27th St
New York, NY 10011

in-sync

ST. ANN'S WAREHOUSE
45 Water Street
Brooklyn, NY 11201

CLIENT
GALLUP®

KEY PLAN

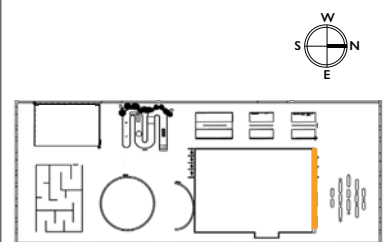

DISCLAIMER
This is an unpublished and proprietary work simultaneously protected under copyright, trade secret, and like laws of the United States and other countries. All rights reserved. These materials may not be reproduced, displayed, distributed, nor may the information therein be used or disclosed in whole or in part, without the express written permission of Emily Yeung Schmidt.

DRAWN BY: EMILY YEUNG SCHMIDT

SCALE: 1/4" = 1'0"

DATE: 12.9.2022

DRAWING TITLE:

INTRODUCTION GRAPHIC

DRAWING NO:

EX501

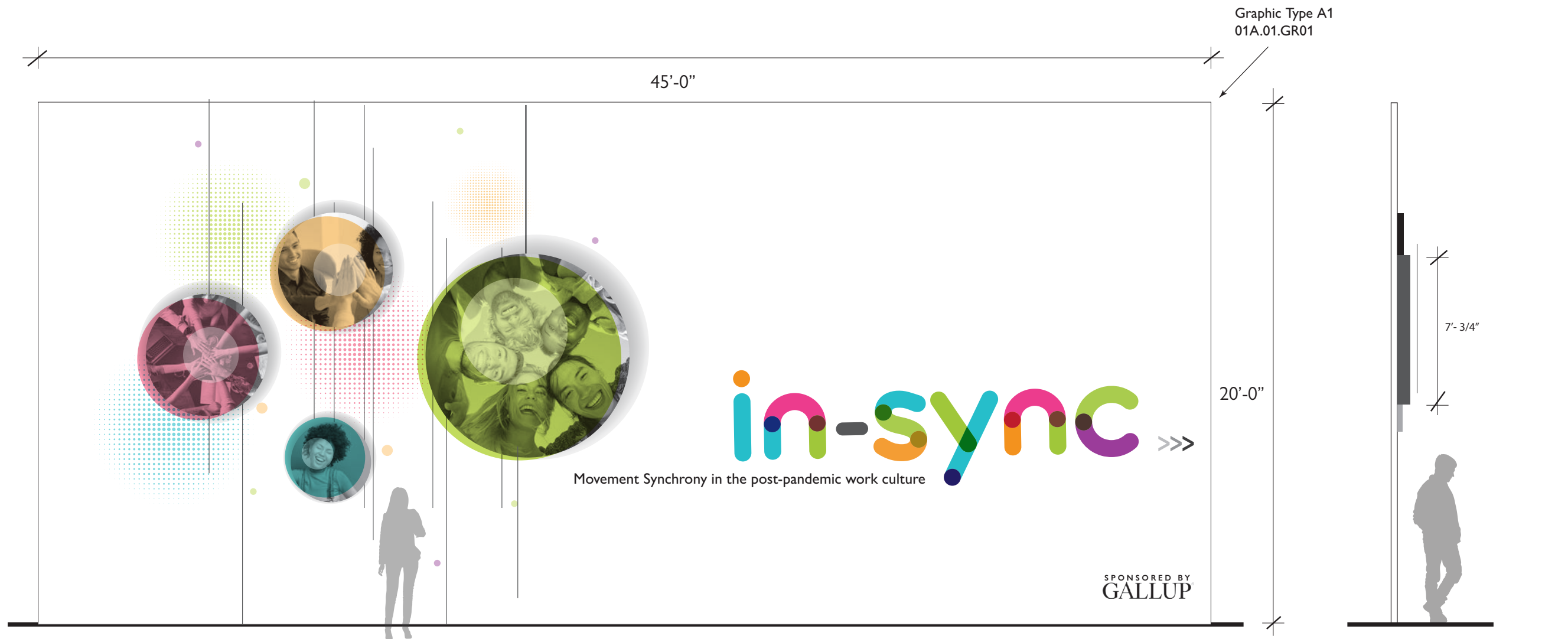

1 ELEVATION 01A-01-GR01-04
SCALE: 1/4" = 1'- 0"

3 SIDE VIEW 01A-01-GR01-04
SCALE: 1/4" = 1'- 0"

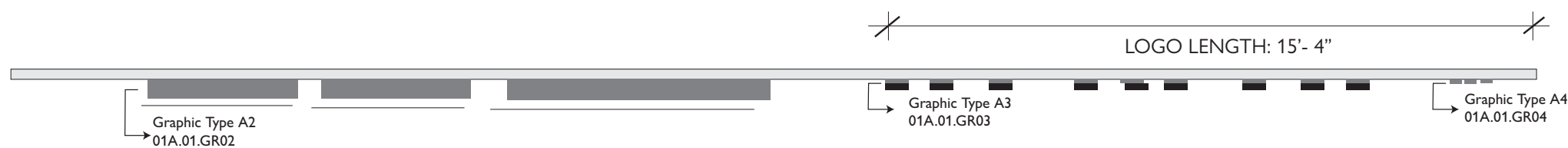

2 PLAN VIEW 01A-01-GR01-04H
SCALE: 1/4" = 1'- 0"

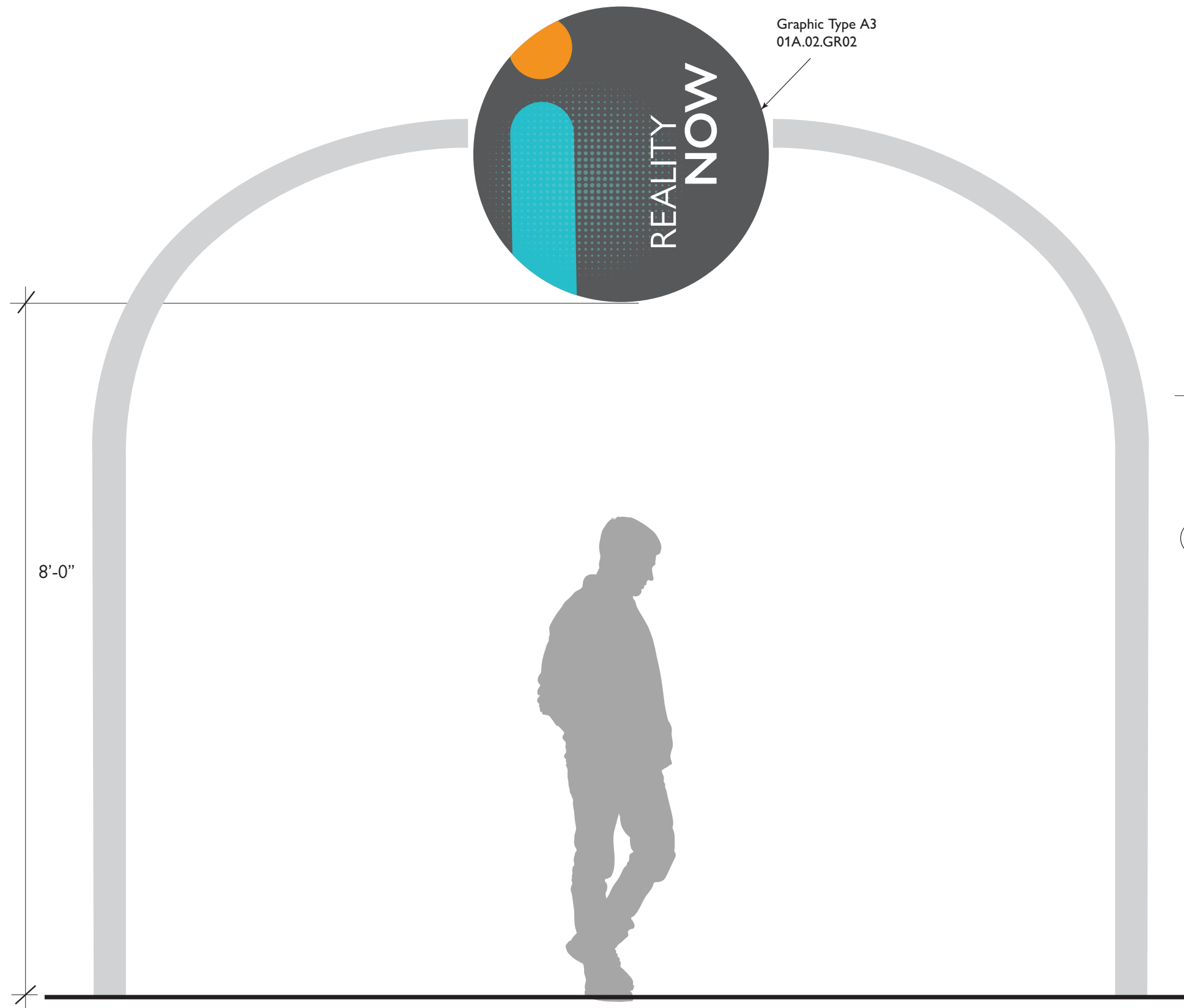

1 ELEVATION 01A-02-GR02
SCALE: 1/2" = 1'-0"

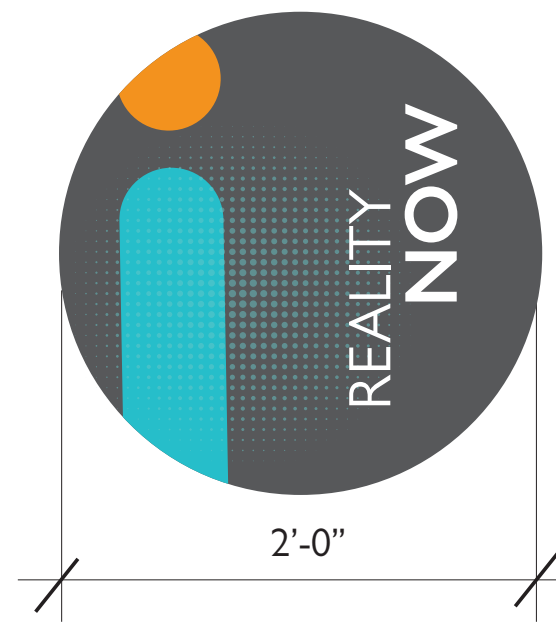

1 FRONT VIEW
SCALE: 1/2" = 1'-0"

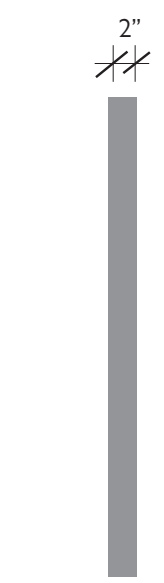

2 SIDE VIEW
SCALE: 1/2" = 1'-0"

EMILY SCHMIDT
MA EXHIBITION & EXPERIENCE DESIGN

FASHION INSTITUTE OF TECHNOLOGY
School of Graduate Studies
272 West 27th St
New York, NY 10011



ST. ANN'S WAREHOUSE
45 Water Street
Brooklyn, NY 11201

CLIENT
GALLUP®

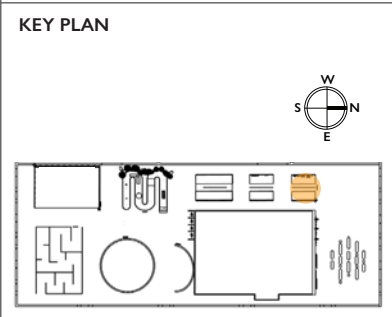

DISCLAIMER
This is an unpublished and proprietary work simultaneously protected under copyright, trade secret, and like laws of the United States and other countries. All rights reserved. These materials may not be reproduced, displayed, distributed, nor may the information therein be used or disclosed in whole or in part, without the express written permission of Emily Yeung Schmidt.

DRAWN BY: EMILY YEUNG SCHMIDT

SCALE: 1/2" = 1'-0"

DATE: 12.9.2022

DRAWING TITLE:
AREA GRAPHIC

DRAWING NO:

EX502

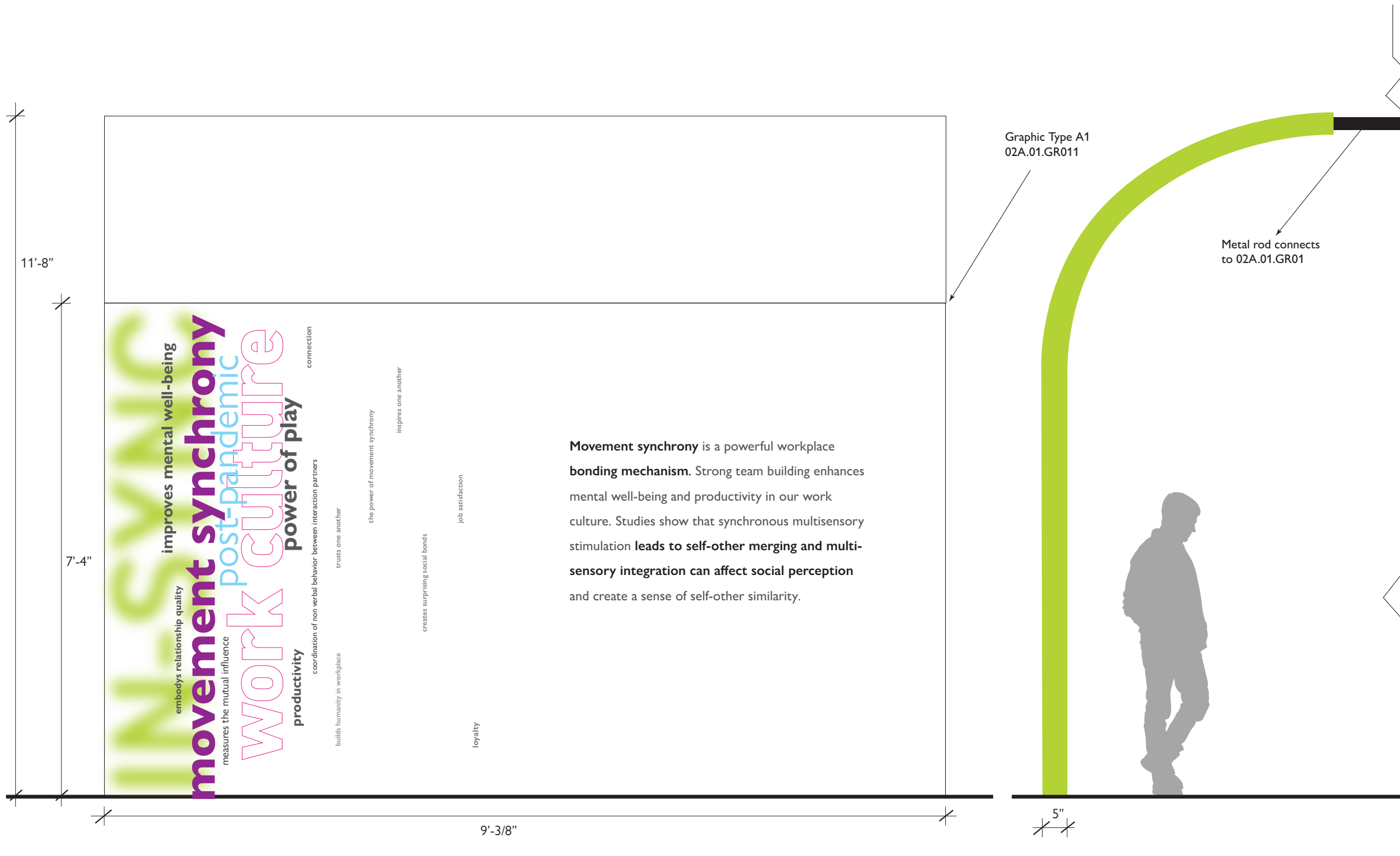

1 ELEVATION 02A-01-GR11
SCALE: 1/2" = 1'-0"

EMILY SCHMIDT
MA EXHIBITION & EXPERIENCE DESIGN

FASHION INSTITUTE OF TECHNOLOGY
School of Graduate Studies
272 West 27th St
New York, NY 10011



ST. ANN'S WAREHOUSE
45 Water Street
Brooklyn, NY 11201

CLIENT
GALLUP®

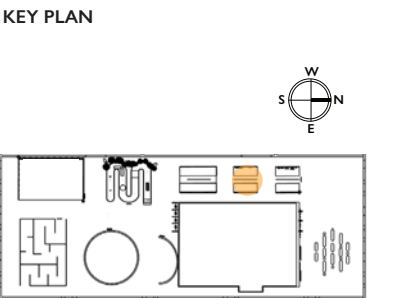

DISCLAIMER
This is an unpublished and proprietary work simultaneously protected under copyright, trade secret, and like laws of the United States and other countries. All rights reserved. These materials may not be reproduced, displayed, distributed, nor may the information therein be used or disclosed in whole or in part, without the express written permission of Emily Yeung Schmidt.

DRAWN BY: EMILY YEUNG SCHMIDT

SCALE: 1/2" = 1'-0"

DATE: 12.9.2022

DRAWING TITLE:
CONTENT GRAPHIC 1

DRAWING NO:

EX503

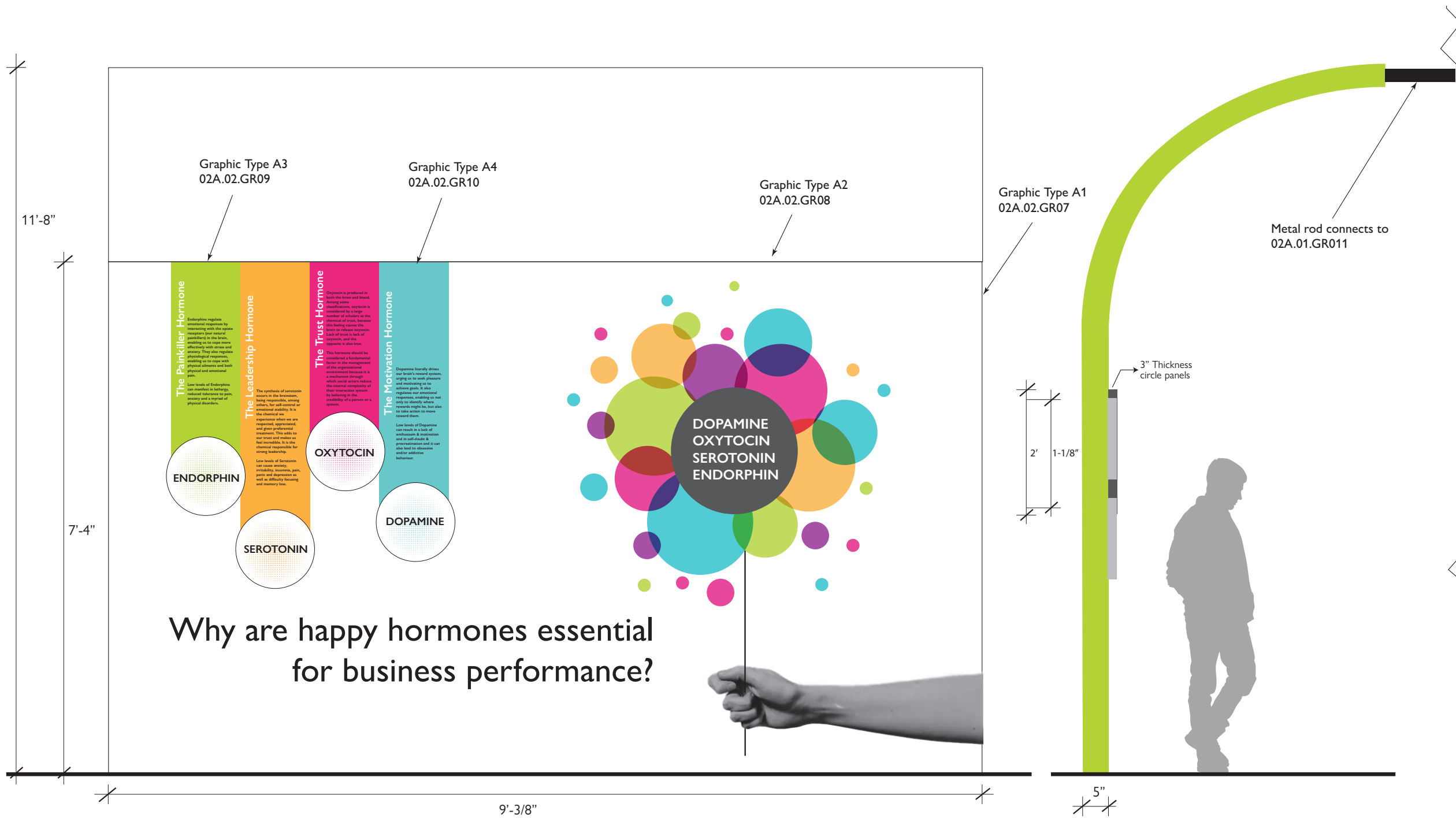

1 ELEVATION 02A.01.GR07-10
SCALE: 3/4" = 1'- 0"

2 SIDE VIEW 02A.01.GR07-10
SCALE: 3/4" = 1'- 0"

EMILY SCHMIDT
MA EXHIBITION & EXPERIENCE DESIGN

FASHION INSTITUTE OF TECHNOLOGY
School of Graduate Studies
272 West 27th St
New York, NY 10011



ST. ANN'S WAREHOUSE
45 Water Street
Brooklyn, NY 11201

CLIENT
GALLUP®

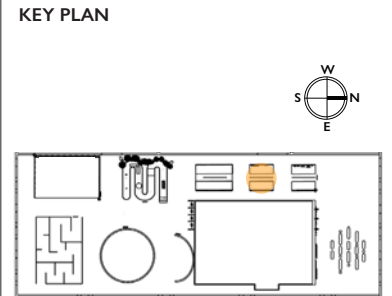

DISCLAIMER
This is an unpublished and proprietary work simultaneously protected under copyright, trade secret, and like laws of the United States and other countries. All rights reserved. These materials may not be reproduced, displayed, distributed, nor may the information therein be used or disclosed in whole or in part, without the express written permission of Emily Yeung Schmidt.

DRAWN BY: EMILY YEUNG SCHMIDT

SCALE: 3/4" = 1'-0"

DATE: 12.9.2022

DRAWING TITLE:
CONTENT GRAPHIC 2

DRAWING NO:

EX504

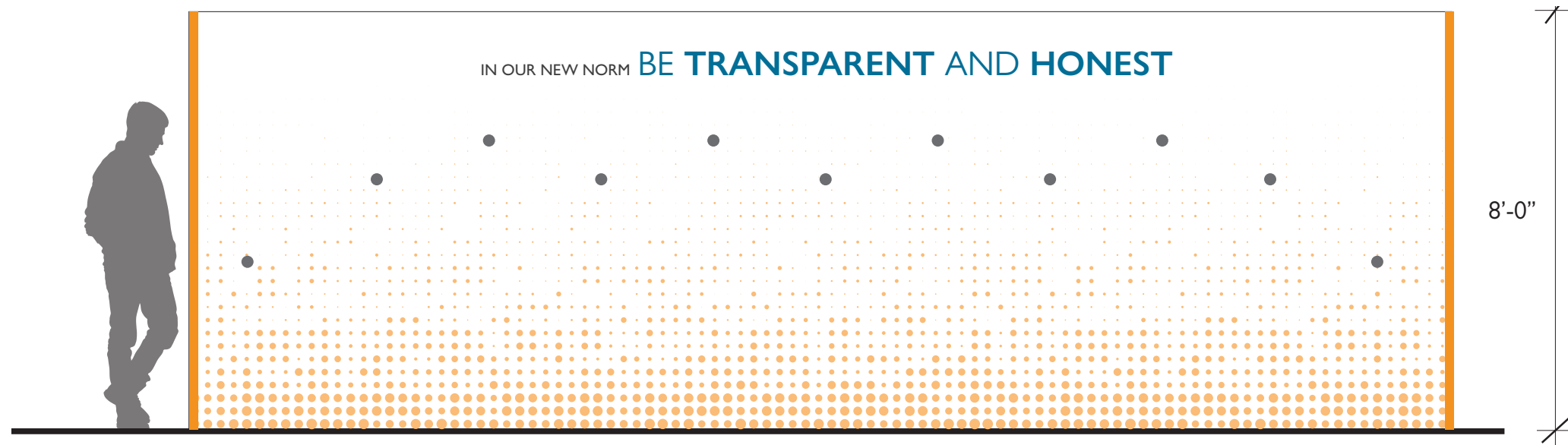

1 ELEVATION 05A.01.GR03
SCALE: 3/8" = 1'-0"

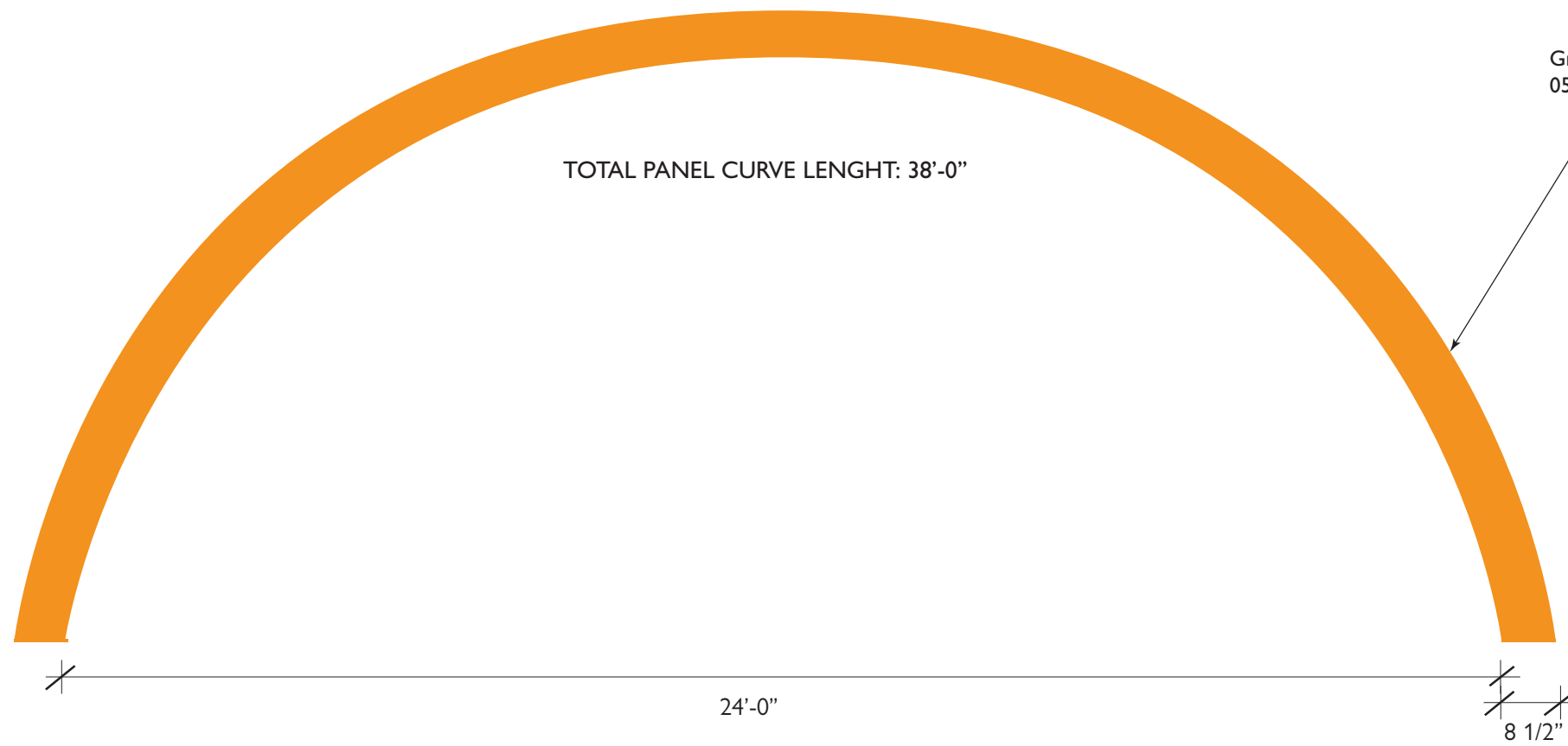

2 PLAN VIEW 05A.01.GR03
SCALE: 3/8" = 1'-0"

EMILY SCHMIDT
MA EXHIBITION & EXPERIENCE DESIGN

FASHION INSTITUTE OF TECHNOLOGY
School of Graduate Studies
272 West 27th St
New York, NY 10011



ST. ANN'S WAREHOUSE
45 Water Street
Brooklyn, NY 11201

CLIENT
GALLUP®

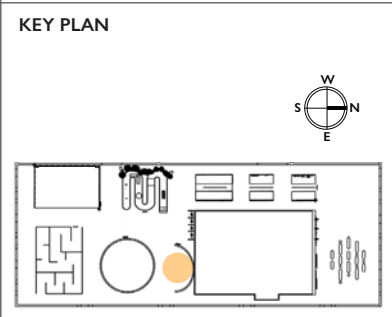

DISCLAIMER
This is an unpublished and proprietary work simultaneously protected under copyright, trade secret, and like laws of the United States and other countries. All rights reserved. These materials may not be reproduced, displayed, distributed, nor may the information therein be used or disclosed in whole or in part, without the express written permission of Emily Yeung Schmidt.

DRAWN BY: EMILY YEUNG SCHMIDT

SCALE: 3/8" = 1'-0"

DATE: 12.9.2022

DRAWING TITLE:
CONTENT GRAPHIC 3

DRAWING NO:

EX505



ST. ANN'S WAREHOUSE
45 Water Street
Brooklyn, NY 11201

CLIENT
GALLUP®

KEY PLAN

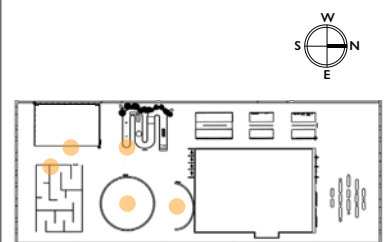

DISCLAIMER
This is an unpublished and proprietary work simultaneously protected under copyright, trade secret, and like laws of the United States and other countries. All rights reserved. These materials may not be reproduced, displayed, distributed, nor may the information therein be used or disclosed in whole or in part, without the express written permission of Emily Yeung Schmidt.

DRAWN BY: EMILY YEUNG SCHMIDT

SCALE: 1-1/2" = 1-0"

DATE: 12.9.2022

DRAWING TITLE:
**CONTENT GRAPHIC —
GOBO PROJECTORS**

DRAWING NO:

EX506

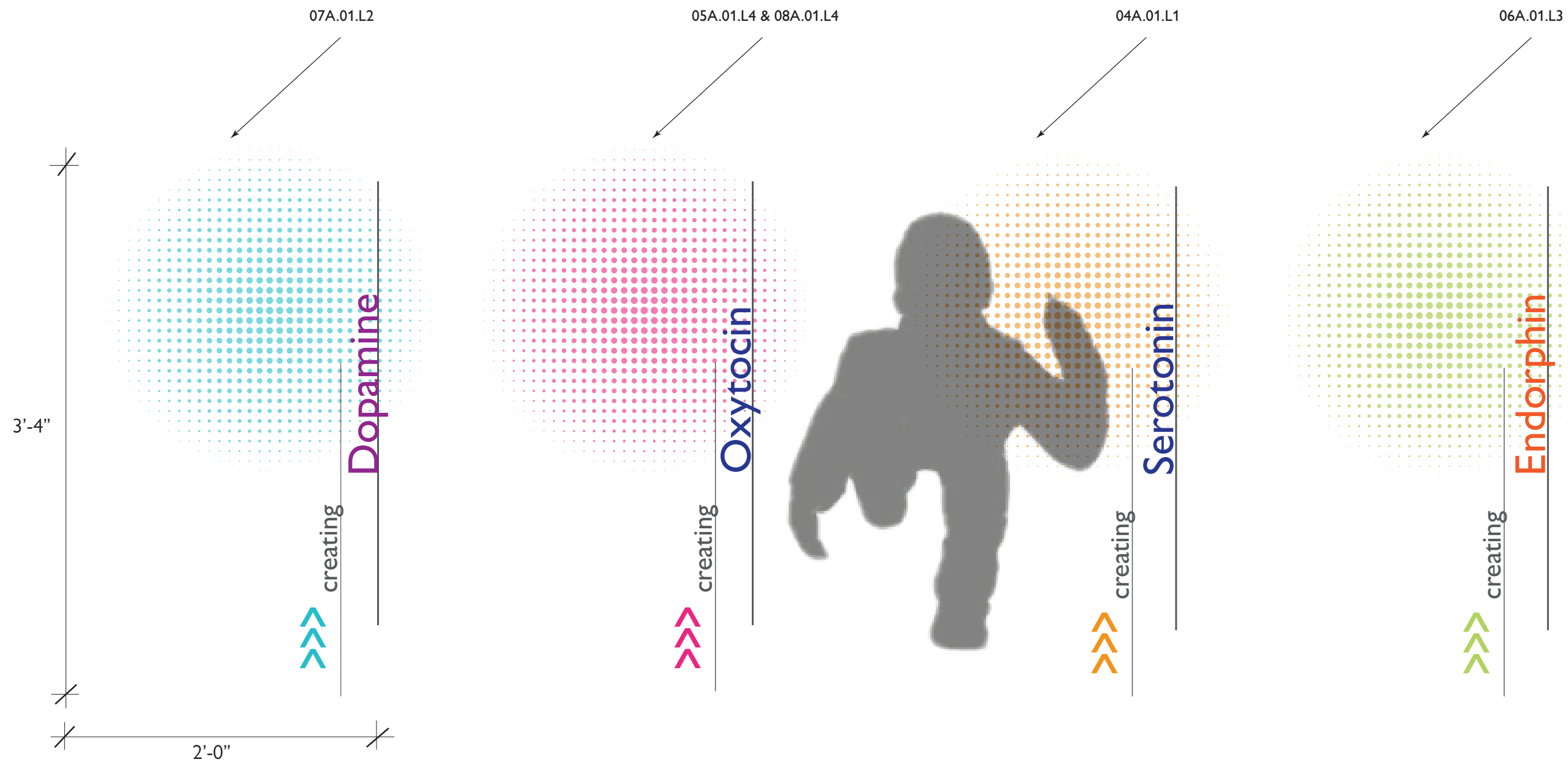

1 GOBO PROJECTOR GRAPHIC
SCALE 1-1/2" = 1'

EMILY SCHMIDT
MA EXHIBITION & EXPERIENCE DESIGN

FASHION INSTITUTE OF TECHNOLOGY
School of Graduate Studies
272 West 27th St
New York, NY 10011



ST. ANN'S WAREHOUSE
45 Water Street
Brooklyn, NY 11201

CLIENT
GALLUP®

KEY PLAN

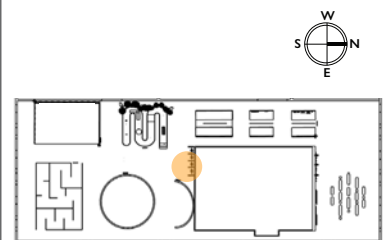

DISCLAIMER
This is an unpublished and proprietary work simultaneously protected under copyright, trade secret, and like laws of the United States and other countries. All rights reserved. These materials may not be reproduced, displayed, distributed, nor may the information therein be used or disclosed in whole or in part, without the express written permission of Emily Yeung Schmidt.

DRAWN BY: EMILY YEUNG SCHMIDT

SCALE: 1" = 1'-0"

DATE: 12.9.2022

DRAWING TITLE:
DIGITAL GRAPHIC TOUCHSCREENS

DRAWING NO:

EX507

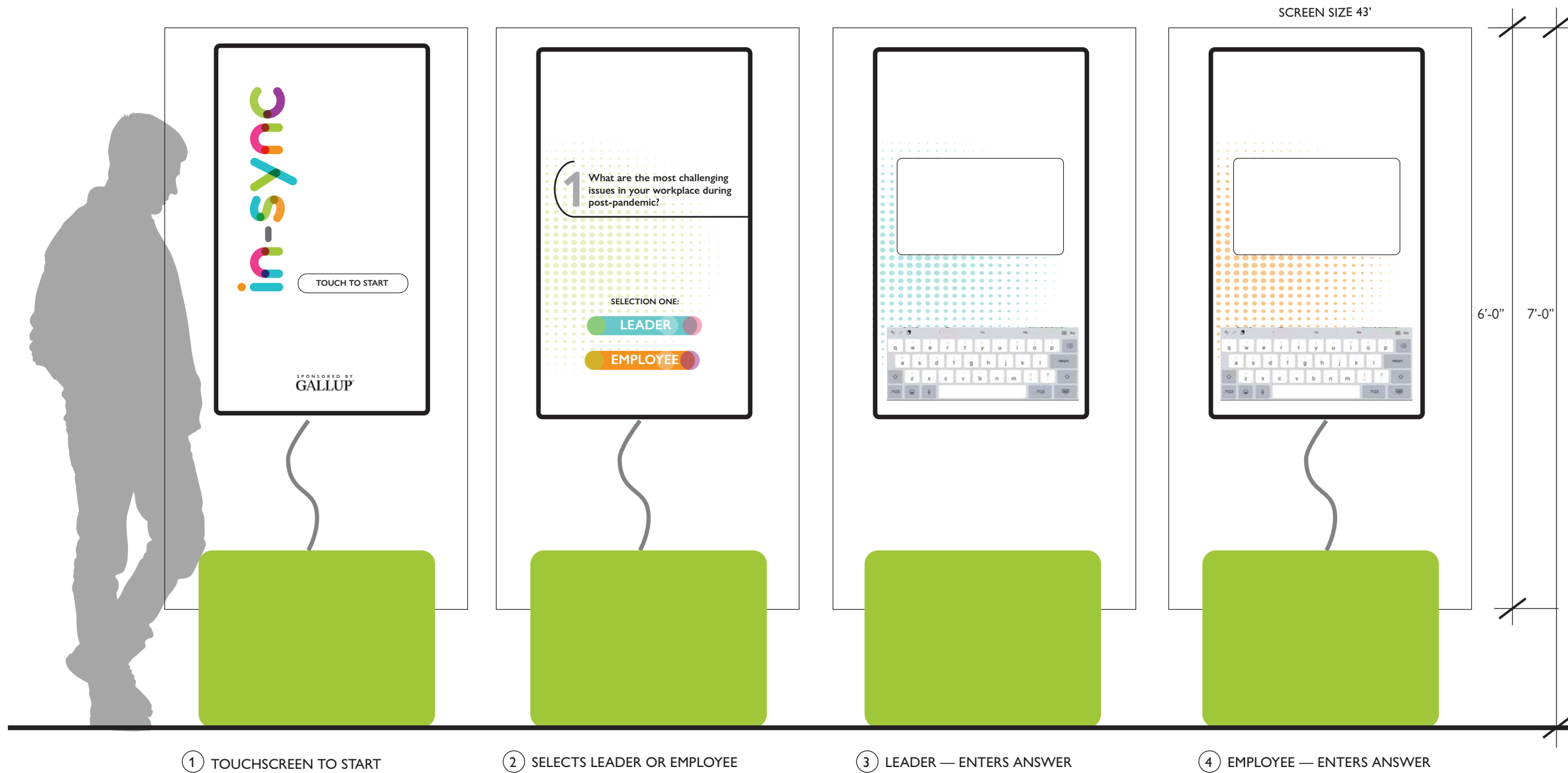

① TOUCHSCREEN TO START

② SELECTS LEADER OR EMPLOYEE

③ LEADER — ENTERS ANSWER

④ EMPLOYEE — ENTERS ANSWER

1 DIGITAL GRAPHIC 05A.01.AV01
SCALE: 1" = 1'-0"

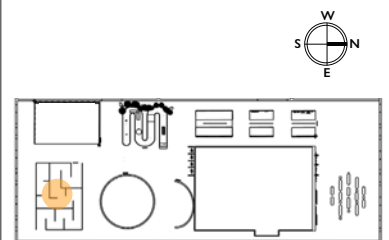

DISCLAIMER
This is an unpublished and proprietary work simultaneously protected under copyright, trade secret, and like laws of the United States and other countries. All rights reserved. These materials may not be reproduced, displayed, distributed, nor may the information therein be used or disclosed in whole or in part, without the express written permission of Emily Yeung Schmidt.

DRAWN BY: EMILY YEUNG SCHMIDT

SCALE: 3/4" = 1'-0"

DATE: 12.9.2022

DRAWING TITLE:
**ACRYLIC PANELS
INSTALLATION
DETAIL**

DRAWING NO:

EX508

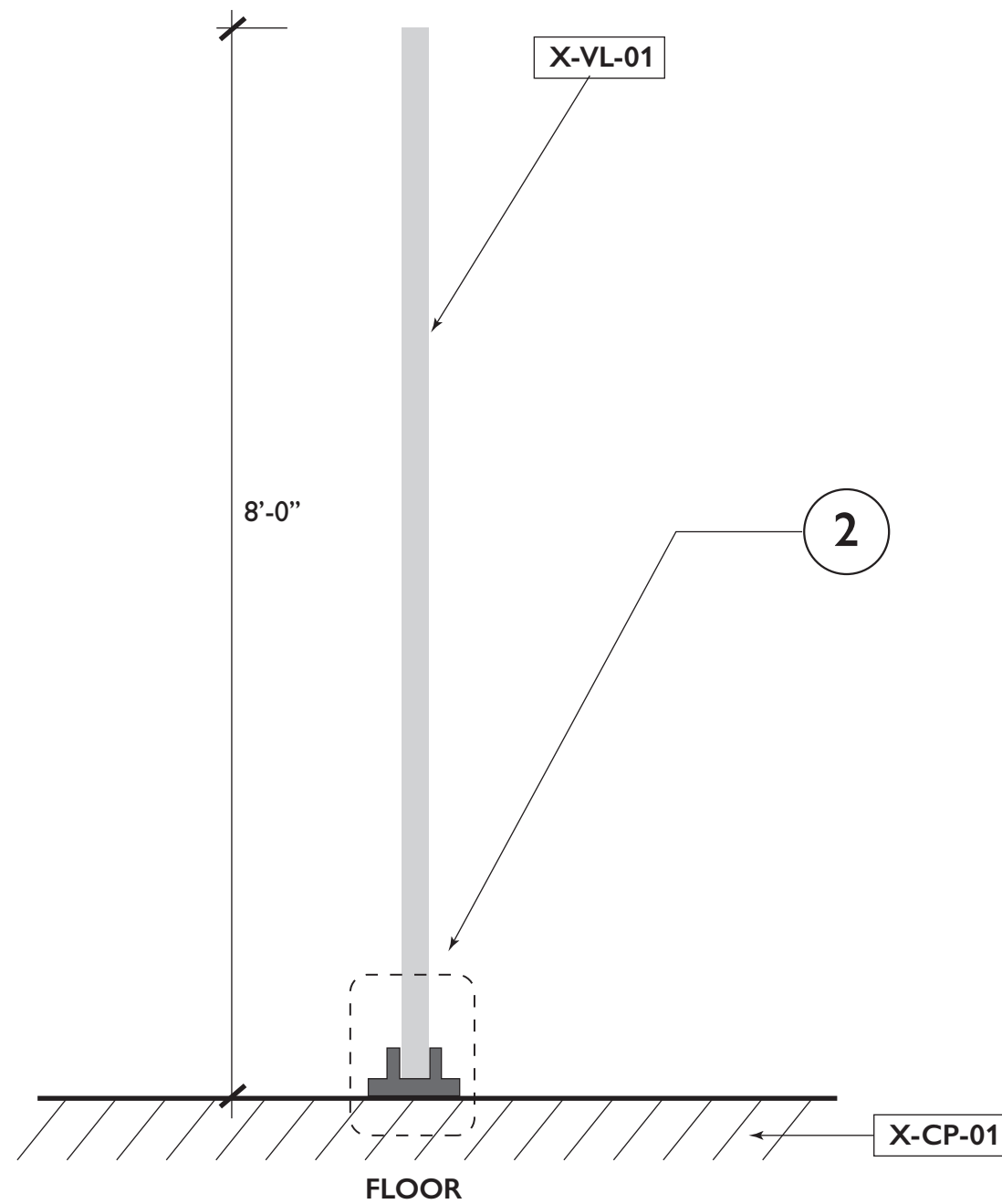

1 ACRYLIC PANEL INSTALLATION X-VL-01
SCALE: 3/4" = 1'-0"

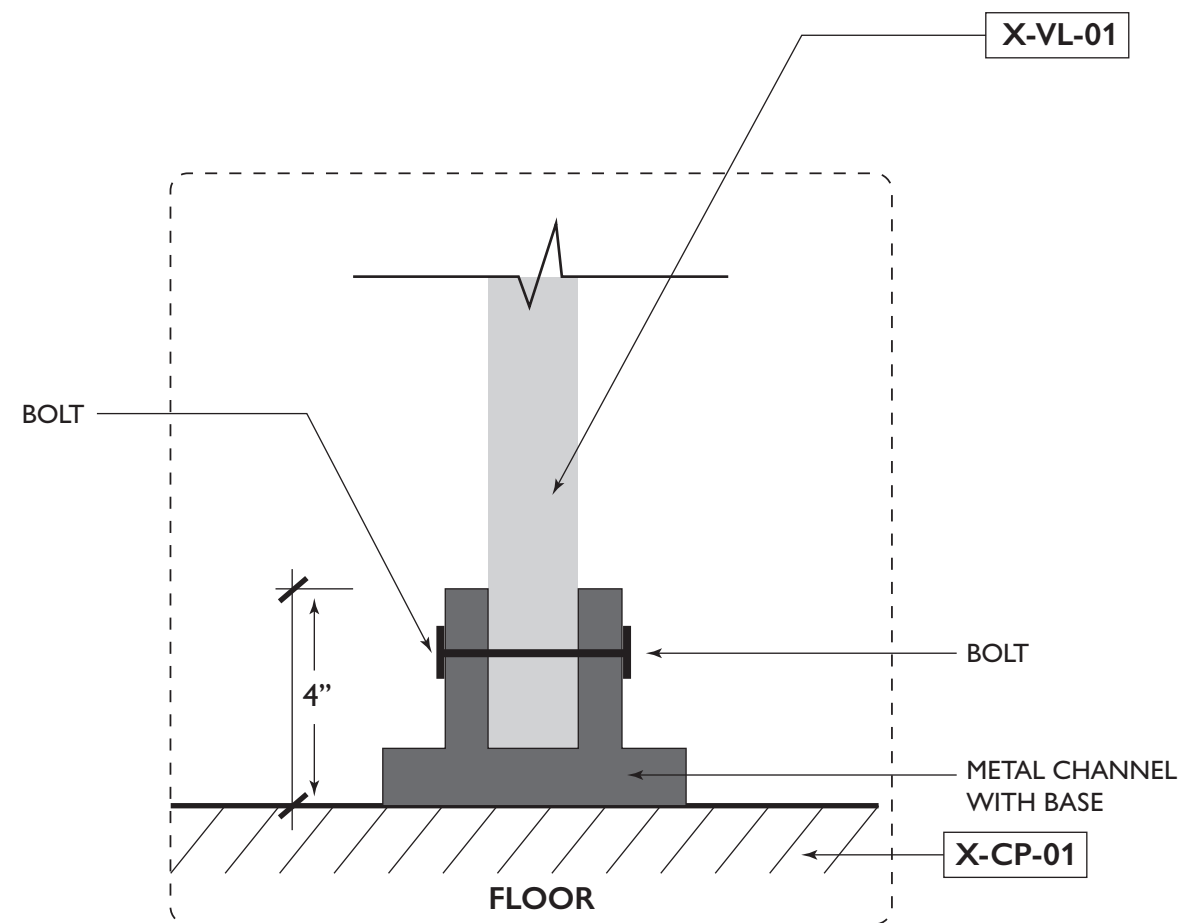

2 ACRYLIC PANEL INSTALLATION DETAIL
SCALE: NTS

EMILY SCHMIDT
MA EXHIBITION & EXPERIENCE DESIGN

FASHION INSTITUTE OF TECHNOLOGY
School of Graduate Studies
272 West 27th St
New York, NY 10011



ST. ANN'S WAREHOUSE
45 Water Street
Brooklyn, NY 11201

CLIENT
GALLUP®

KEY PLAN

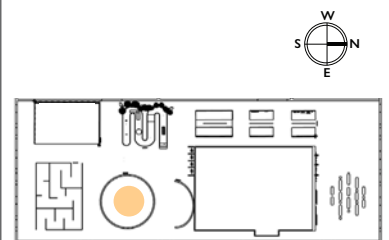

DISCLAIMER
This is an unpublished and proprietary work simultaneously protected under copyright, trade secret, and like laws of the United States and other countries. All rights reserved. These materials may not be reproduced, displayed, distributed, nor may the information therein be used or disclosed in whole or in part, without the express written permission of Emily Yeung Schmidt.

DRAWN BY: EMILY YEUNG SCHMIDT

SCALE: 1/4" = 1'-0"

DATE: 12.9.2022

DRAWING TITLE:
**PROJECTION MAPPING
DETAIL**

DRAWING NO:

EX509

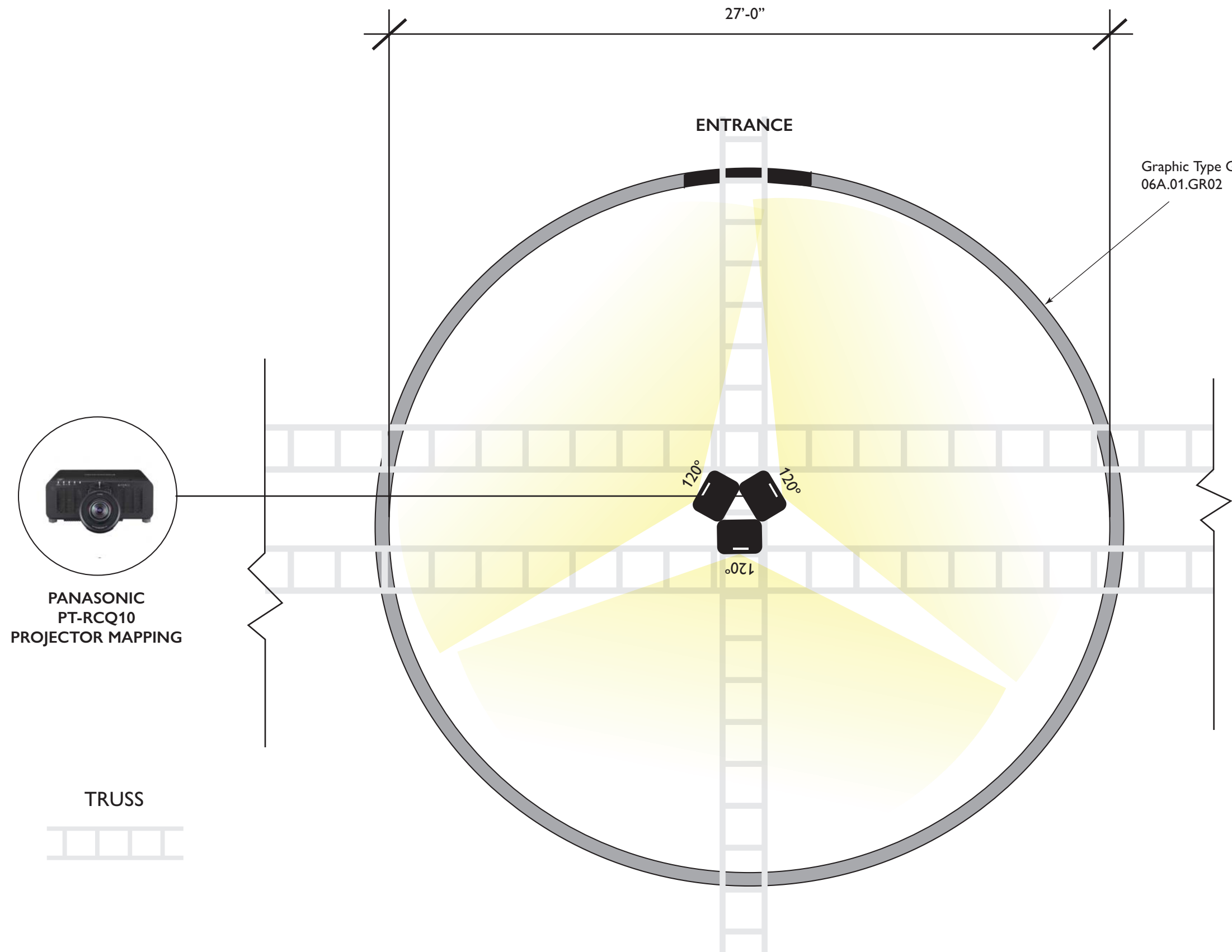

1 PROJECTION MAPPING PLAN VIEW 06A.01.AV01
SCALE: 1/4" = 1'-0"

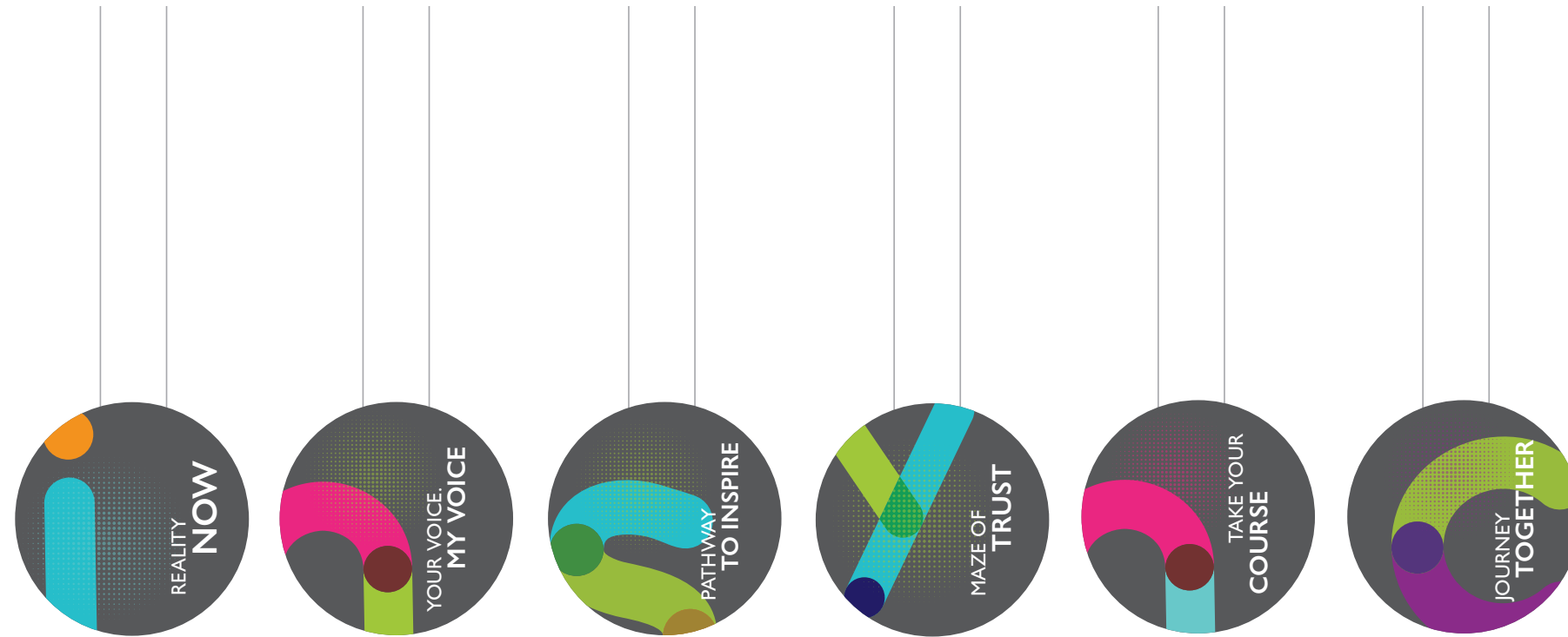

100% DESIGN DEVELOPMENT PACKAGE
THESIS CAPSTONE 2022

Copyright © 2022 by Emily Schmidt. All Rights Reserved.