



A mutually beneficial relationship between humans and horses.

DESIGN DEVELOPMENT PACKAGE

GRADUATE THESIS

MA EXHIBITION AND EXPERIENCE DESIGN
SUNY FASHION INSTITUTE OF TECHNOLOGY

FLAVIA PEDROSA TONIETTO



PROJECT
HORSECENTRISM
THESIS CAPSTONE
EXHIBIT

DRAWN BY
FLAVIA PEDROSA TONIETTO

SITE
**PARK AVENUE ARMORY
NEW YORK**

CLIENTS



KEY PLAN

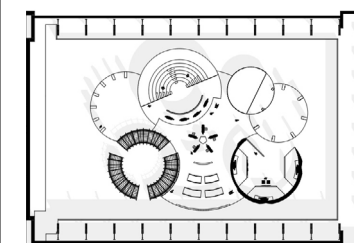

NOTES
DRAWINGS FOR
DESIGN INTENT
ONLY

DRAWING
DRAWING LIST

SCALE
NTS

DATE
DEC.06.2023

DRAWING NO
EX0.02

DRAWING LIST

EX.0.00 GENERAL

- EX.0.01 COVER PAGE
- EX.0.02 DRAWING LIST
- EX.0.03 DRAWING LIST CONT'D
- EX.0.04 DRAWING LIST CONT'D

EX.1.00 EXECUTIVE SUMMARY

- EX.1.01 BIG IDEA STATEMENT
- EX.1.02 PROJECT PARAMETERS | SUBJECT
- EX.1.03 PROJECT PARAMETERS | CLIENT
- EX.1.04 PROJECT PARAMETERS | CLIENT
- EX.1.05 PROJECT PARAMETERS | AUDIENCE
- EX.1.06 PROJECT PARAMETERS | VENUE
- EX.1.07 PROJECT & EXHIBITION DESCRIPTION
- EX.1.08 GOALS
- EX.1.09 CONCEPT DIAGRAM
- EX.1.10 BUBBLE FLOOR PLAN
- EX.1.11 CONCEPT ON PLAN
- EX.1.12 EXPERIENCE DESCRIPTION
- EX.1.13 00A: WAYFINDING RENDER
- EX.1.14 00A: WAYFINDING RENDER
- EX.1.15 00A: WAYFINDING RENDER
- EX.1.16 00B: AXONOMETRIC
- EX.1.17 MODEL
- EX.1.18 MODEL CONT'D
- EX.1.19 MODEL CONT'D
- EX.1.20 MODEL CONT'D
- EX.1.21 01B EXPERIENCE DESCRIPTION
- EX.1.22 01B RENDER

- EX.1.23 02B EXPERIENCE DESCRIPTION
- EX.1.24 02B RENDER
- EX.1.25 03B EXPERIENCE DESCRIPTION
- EX.1.26 03B AMPHITEATHER RENDER
- EX.1.27 03B CAVE PAINTINGS RENDER
- EX.1.28 03B PUPPET WORKSHOP RENDER
- EX.1.29 04B EXPERIENCE DESCRIPTION
- EX.1.30 04B RENDER
- EX.1.31 05B EXPERIENCE DESCRIPTION
- EX.1.32 05B RENDER
- EX.1.33 06B EXPERIENCE DESCRIPTION
- EX.1.34 06B PROJECTION ROOM RENDER
- EX.1.35 06B SHARING PANEL RENDER
- EX.1.36 07B EXPERIENCE DESCRIPTION
- EX.1.37 07B HORSE SIMULATOR RENDER
- EX.1.38 07B TESTIMONIALS RENDER
- EX.1.39 DURATION & STAFF ROLES
- EX.1.40 POST VISIT ENGAGEMENT

EX.2.00 SCHEDULES AND LISTS

- EX.2.01 GRAPHIC SCHEDULE
- EX.2.02 GRAPHIC SCHEDULE CONT'D
- EX.2.03 GRAPHIC SCHEDULE CONT'D
- EX.2.04 GRAPHIC SCHEDULE CONT'D
- EX.2.05 GRAPHIC SCHEDULE CONT'D
- EX.2.06 GRAPHIC SPECIFICATION LIST
- EX.2.07 FINISH SCHEDULE
- EX.2.08 FINISH SCHEDULE CONT'D
- EX.2.09 FINISH SCHEDULE CONT'D
- EX.2.10 AV SCHEDULE
- EX.2.11 LIGHTING SCHEDULE
- EX.2.12 OBJECT SCHEDULE



PROJECT
HORSECENTRISM
THESIS CAPSTONE
EXHIBIT

DRAWN BY
FLAVIA PEDROSA TONIETTO

SITE
**PARK AVENUE ARMORY
NEW YORK**

CLIENTS



KEY PLAN

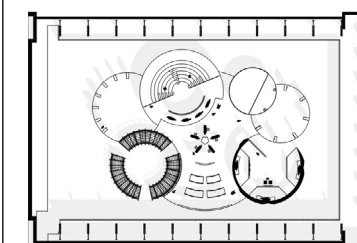

NOTES
DRAWINGS FOR
DESIGN INTENT
ONLY

DRAWING
DRAWING LIST

SCALE
NTS

DATE
DEC.06.2023

DRAWING NO
EX0.03

EX.2.13 OBJECT SCHEDULE CONT'D
EX.2.14 OBJECT SCHEDULE CONT'D
EX.2.15 OBJECT SCHEDULE CONT'D

EX.3.00 PLANS, ELEVATIONS, & SECTIONS

EX.3.01 SYMBOLS LIST
EX.3.02 LOCATION PLAN
EX.3.03 GRAPHIC LOCATION PLAN
EX.3.04 SITE PLAN
EX.3.05 CODED FLOOR PLAN
EX.3.06 GRAPHIC LOCATION PLAN
EX.3.07 FINISH PLAN
EX.3.08 AV PLAN
EX.3.09 REFLECTED CEILING PLAN
EX.3.10 TRANSVERSAL & LONGITUDINAL SECTIONS
EX.3.11 01B DIMENSIONED PLAN
EX.3.12 01B SECTION
EX.3.13 02B DIMENSIONED PLAN
EX.3.14 02B AV PLAN
EX.3.15 02B SECTION
EX.3.16 03B DIMENSIONED PLAN
EX.3.17 03B SECTION
EX.3.18 04B DIMENSIONED PLAN
EX.3.19 04B SECTION
EX.3.20 05B DIMENSIONED PLAN
EX.3.21 05B SECTION
EX.3.22 06B DIMENSIONED PLAN
EX.3.23 06B SECTION
EX.3.24 07B DIMENSIONED PLAN
EX.3.25 07B OBJECT PLAN
EX.3.26 07B SECTION

EX.4.00 GRAPHICS

EX.4.01 GRAPHIC LOOK & FEEL
EX.4.02 GRAPHIC IDENTITY
EX.4.03 LOGO
EX.4.04 COLLATERAL
EX.4.05 POSTER
EX.4.06 POSTER APPLIED
EX.4.07 POSTER APPLIED CONT'D
EX.4.08 POSTER APPLIED CONT'D
EX.4.09 POSTER APPLIED CONT'D
EX.4.10 WAYFINDING
EX.4.11 WAYFINDING CONT'D
EX.4.12 WAYFINDING CONT'D
EX.4.13 INTRODUCTION GRAPHIC
EX.4.14 AREA INTRODUCTION GRAPHIC
EX.4.15 AREA INTRODUCTION GRAPHIC CONT'D
EX.4.16 AREA INTRODUCTION GRAPHIC CONT'D
EX.4.17 AREA INTRODUCTION GRAPHIC CONT'D
EX.4.18 CONTENT GRAPHICS
EX.4.19 CONTENT GRAPHICS CONT'D
EX.4.20 CONTENT GRAPHICS CONT'D
EX.4.21 CONTENT GRAPHICS CONT'D

EX.5.00 DETAILS

EX.5.01 04B EXTERNAL WALL PLAN
EX.5.02 04B UNFOLDED ELEVATIONS
EX.5.03 04B UNFOLDED ELEVATIONS
EX.5.04 04B CENTRAL WALLS PLAN
EX.5.05 04B WALL A
EX.5.06 04B WALL B

- EX.5.07** 04B WALL C
- EX.5.08** 04B AXONOMETRIC
- EX.5.09** 04B AXONOMETRIC
- EX.5.10** 07B PLAN
- EX.5.11** 07B DETAIL 1
- EX.5.12** 07B DETAIL 2
- EX.5.13** 07B DETAIL 3



PROJECT
HORSECENTRISM
THESIS CAPSTONE
EXHIBIT

DRAWN BY
FLAVIA PEDROSA TONIETTO

SITE
**PARK AVENUE ARMORY
NEW YORK**

CLIENTS



KEY PLAN

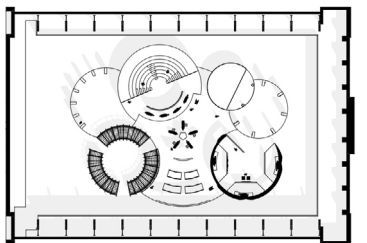

NOTES
DRAWINGS FOR
DESIGN INTENT
ONLY

DRAWING
DRAWING LIST

SCALE
NTS

DRAWING NO
EX0.04

DATE
DEC.06.2023

EXECUTIVE SUMMARY



PROJECT
HORSECENTRISM
THESIS CAPSTONE
EXHIBIT

DRAWN BY
FLAVIA PEDROSA TONIETTO

SITE
**PARK AVENUE ARMORY
NEW YORK**



BIG IDEA STATEMENT

Simply interacting with a horse has the potential to positively impact people's lives. The recognition of qualities in the horse gave rise to Equine Assisted Therapy: practice that understands the horse as a health-promoting agent. Providing the horse with quality of life is essential for building a relationship of mutual benefit, as well as an opportunity to repay all the good that the horse has provided to humanity. This is Horsecentrism, a mutually beneficial relationship between humans and horses. The Horsecentrism exhibition aims to publicize and make accessible the practice of equine therapy, as well as beneficial practices for the horse.

KEY PLAN

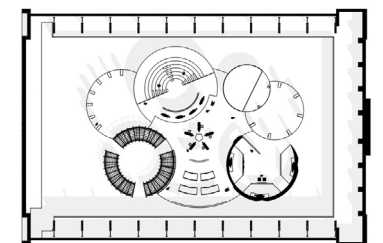

NOTES
DRAWINGS FOR
DESIGN INTENT
ONLY

DRAWING
THESIS STATEMENT

SCALE
NTS

DRAWING NO
EX1.01

DATE
DEC.06.2023



PROJECT
HORSECENTRISM
THESIS CAPSTONE
EXHIBIT

DRAWN BY
FLAVIA PEDROSA TONIETTO

SITE
**PARK AVENUE ARMORY
NEW YORK**

CLIENTS



KEY PLAN

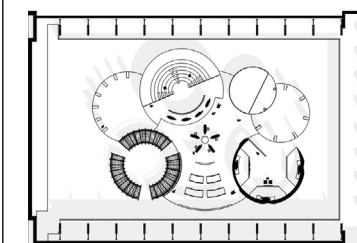

NOTES
DRAWINGS FOR
DESIGN INTENT
ONLY

DRAWING
PROJECT PARAMETERS

SCALE
NTS

DRAWING NO
EX1.02

DATE
DEC.06.2023

PROJECT PARAMETERS

SUBJECT

Through the theme of **HORSES AND EQUINE THERAPY**, the exhibition explores the relationships that developed between humans and horses. From the beginning, when horses were represented in caves, being hunted, or later incorporated into society through sports, the horse has always been present. Moreover, the horse has been used as a healing agent since very early times. Hippocrates, in his book "De Dieta", advised horse riding as a treatment for pathologies, as it benefited health in general. The project seeks to represent these relationships through time, but mainly to disseminate the horse's contribution to therapies.





CLIENT

PATH INTERNATIONAL

Mission: To ensure universal recognition of professional equine-assisted services and the transformative impacts that enrich lives.

Vision: PATH Intl. believes in the inherent worth and dignity of every person and recognizes the historical and current lack of diversity within the equine-assisted services industry. We commit to increasing diversity, equity and inclusion, leading by example within the equine assisted services industry, and expanding access and opportunity for all people. We will provide education and resources and collaborate with marginalized and/or underrepresented people and communities, while actively seeking representation from those communities for our governing Board of Trustees, staff, members, certificant and volunteers.



PROJECT
HORSECENTRISM
THESIS CAPSTONE
EXHIBIT

DRAWN BY
FLAVIA PEDROSA TONIETTO

SITE
**PARK AVENUE ARMORY
NEW YORK**

CLIENTS



KEY PLAN

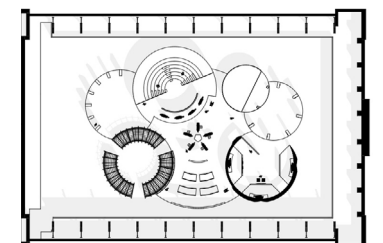

NOTES
DRAWINGS FOR
DESIGN INTENT
ONLY

DRAWING
PROJECT PARAMETERS

SCALE
NTS

DRAWING NO
EX1.03

DATE
DEC.06.2023



CLIENT

GERMAN EQUESTRIAN FEDERATION(FN)

The FN is the umbrella organization for nearly all equestrian sports and breeding associations in Germany.

Mission: The promotion of equestrian sport and horse breeding, the provision of guidance and services, and the preservation of the historic relationship between man and horse.

Responsibilities and Objectives

Promotion of:

- Joy of living,
- Training and education,
- The sport for pleasure and performance,
- German horses and breeding,
- Horse keeping,
- Animal welfare,
- Environmental responsibility and care for the environment,
- Responsible horse care.



PROJECT
HORSECENTRISM
THESIS CAPSTONE
EXHIBIT

DRAWN BY
FLAVIA PEDROSA TONIETTO

SITE
**PARK AVENUE ARMORY
NEW YORK**

CLIENTS



KEY PLAN

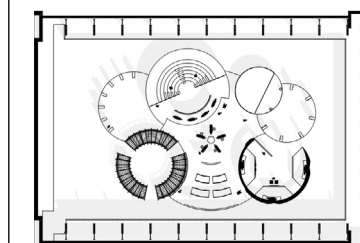

NOTES
DRAWINGS FOR
DESIGN INTENT
ONLY

DRAWING
PROJECT PARAMETERS

SCALE
NTS

DRAWING NO
EX1.04

DATE
DEC.06.2023



PROJECT
HORSECENTRISM
THESIS CAPSTONE
EXHIBIT

DRAWN BY
FLAVIA PEDROSA TONIETTO

SITE
**PARK AVENUE ARMORY
NEW YORK**



KEY PLAN

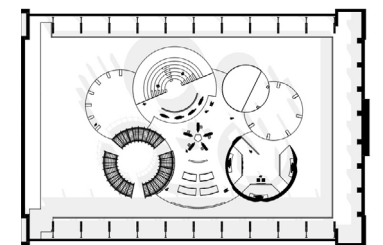

NOTES
DRAWINGS FOR
DESIGN INTENT
ONLY

DRAWING
PROJECT PARAMETERS

SCALE
NTS

DRAWING NO
EX1.05

DATE
DEC.06.2023

AUDIENCE

Primary: Local and international tourists (Explorers, Experience Seekers, Facilitators).

Secondary: People who are directly involved with horses, such as equine therapy professionals, professional riders, and amateurs. People who provide any service to the welfare of horses (Hobbyists, Experience Seekers, Facilitators, Rechargers).

Tertiary: Horse Lovers (Explorers, Experience Seekers).





PROJECT
HORSECENTRISM
THESIS CAPSTONE
EXHIBIT

DRAWN BY
FLAVIA PEDROSA TONIETTO

SITE
**PARK AVENUE ARMORY
NEW YORK**



KEY PLAN

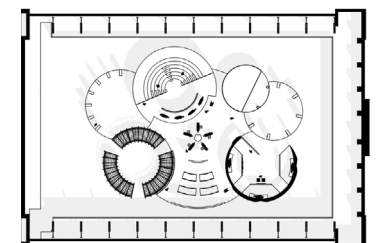

NOTES
DRAWINGS FOR
DESIGN INTENT
ONLY

DRAWING
PROJECT PARAMETERS

SCALE
NTS

DRAWING NO
EX1.06

DATE
DEC.06.2023

VENUE

PARK AVENUE ARMORY

Completed in 1881, the Armory served as a military, cultural and social center for the Regiment as well as New York society of the Gilded Age.

WADE THOMPSON DRILL HALL

A monument in the history of American engineering. 55,000 square feet of open, uncolumned space. 80-foot-high barrel vaulted roof or “ballon shed” is the oldest of this scale in America, featuring eleven elliptical wrought iron arches designed by Charles Macdonald.





PROJECT
HORSECENTRISM
THESIS CAPSTONE
EXHIBIT

DRAWN BY
FLAVIA PEDROSA TONIETTO

SITE
**PARK AVENUE ARMORY
NEW YORK**

CLIENTS



KEY PLAN

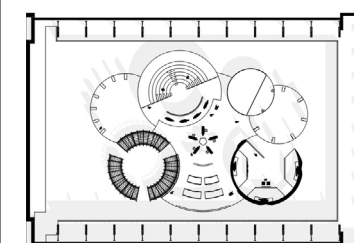

NOTES
DRAWINGS FOR
DESIGN INTENT
ONLY

DRAWING
**PROJECT & EXHIBITION
DESCRIPTION**

SCALE
NTS

DRAWING NO
EX1.07

DATE
DEC.06.2023

PROJECT INTRODUCTION

Through the theme of Horses and Equine Therapy, I sought to explore factors that affect people's behavior in exhibition environments. To explore the way visitors move around exhibition environments, I opted for an open floor plan, which gives visitors greater freedom to choose their path. The exhibition takes place in circular areas around the main theme: Equine Therapy. There are two groups containing three themes. The first group is divided into Armies and Warriors, WWI, and Horses and the Arts, while the second group is divided into: Equestrian World, A Billion-Dollar Industry, and The Equine Carbon "Hoofprint". My goal is to make visitors understand the relationship that existed and still exists between humans and horses, bringing an approach focused on the well-being of both, but especially the horse. The clients provide a real opportunity and example of the relationship between humans and horses today.

EXHIBITION DESCRIPTION

Through the theme of Horse and Equine Therapy, the project explores the way in which visitors interpret the space and consequently move through it. The exhibition explores the relationships that developed between humans and horses. From the beginning, when horses were represented in caves, being hunted, or later incorporated into society through sports, the horse has always been present. Moreover, the horse has been used as a healing agent since very early times. Hippocrates, in his book "De Dieta", advised horse riding as a treatment for pathologies, as it benefited health in general. The project seeks to represent these relationships through time, but mainly to disseminate the horse's contribution to therapies.



PROJECT
HORSECENTRISM
THESIS CAPSTONE
EXHIBIT

DRAWN BY
FLAVIA PEDROSA TONIETTO

SITE
**PARK AVENUE ARMORY
NEW YORK**



KEY PLAN

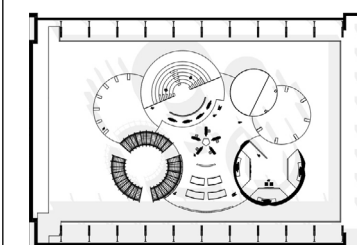

NOTES
DRAWINGS FOR
DESIGN INTENT
ONLY

DRAWING
GOALS

SCALE
NTS

DRAWING NO
EX1.08

DATE
DEC.06.2023

PROJECT GOALS

The exhibition will show:

- How people navigate and circulate in exhibitions.
- If there are predominant patterns in people's behavior.
- If elements of the exhibition influence the path taken.
- How the layout interferes with circulation.

EDUCATION GOALS

Visitors will learn about:

- The horses' contribution to shaping the world and specifically in WWI.
- Paintings of horses in caves, War Horse Performance made with life-size puppets.
- The use of horses in assisted therapies.
- What are the German practices and why do Germans stand out in equestrian competitions.

EXPERIENCE GOALS

Visitors will experience:

- Competition games that, in addition to teaching, bring out in visitors the competitive side present in equestrian competitions.
- Encourage curiosity to create connections and empathy through what horses experience in WWI.
- A simulation of an equine-assisted therapy session will help visitors understand what the benefits of therapy are and why this treatment is used.



PROJECT
HORSECENTRISM
THESIS CAPSTONE
EXHIBIT

DRAWN BY
FLAVIA PEDROSA TONIETTO

SITE
**PARK AVENUE ARMORY
NEW YORK**



KEY PLAN

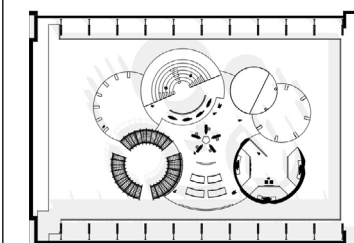

NOTES
DRAWINGS FOR
DESIGN INTENT
ONLY

DRAWING
CONCEPT DIAGRAM

SCALE
NTS

DRAWING NO
EX1.09

DATE
DEC.06.2023

CONCEPT DIAGRAM

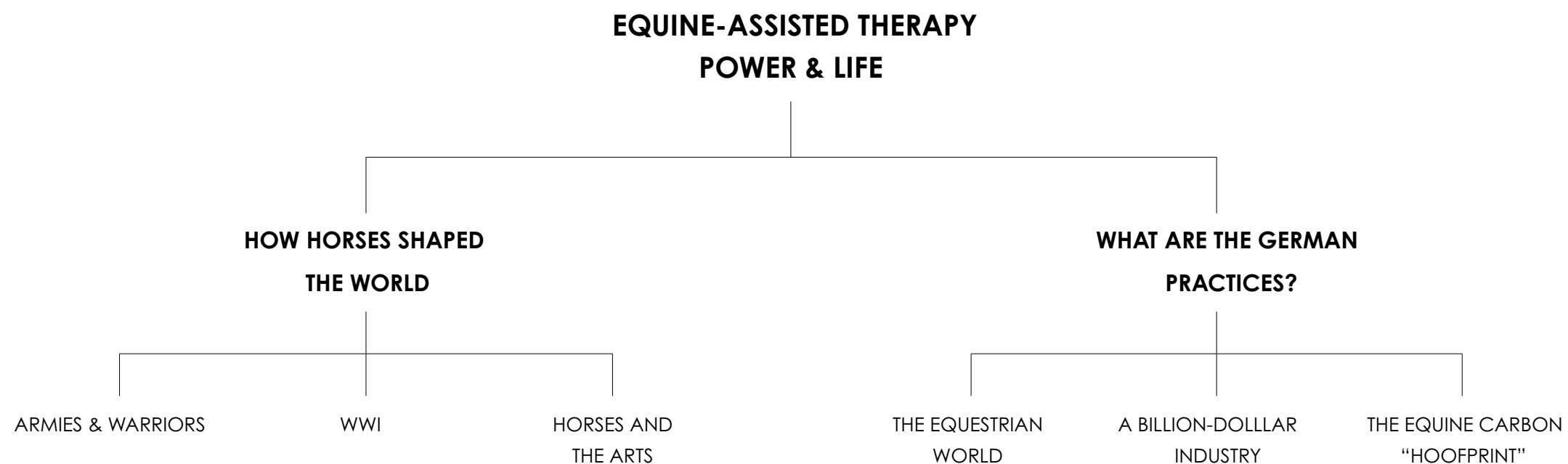



PROJECT
HORSECENTRISM
THESIS CAPSTONE
EXHIBIT

DRAWN BY
FLAVIA PEDROSA TONIETTO

SITE
**PARK AVENUE ARMORY
NEW YORK**



KEY PLAN

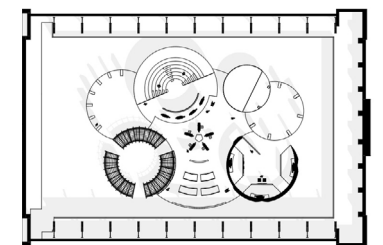

NOTES
DRAWINGS FOR
DESIGN INTENT
ONLY

DRAWING
BUBBLE FLOOR PLAN

SCALE
NTS

DRAWING NO
EX1.10

DATE
DEC.06.2023

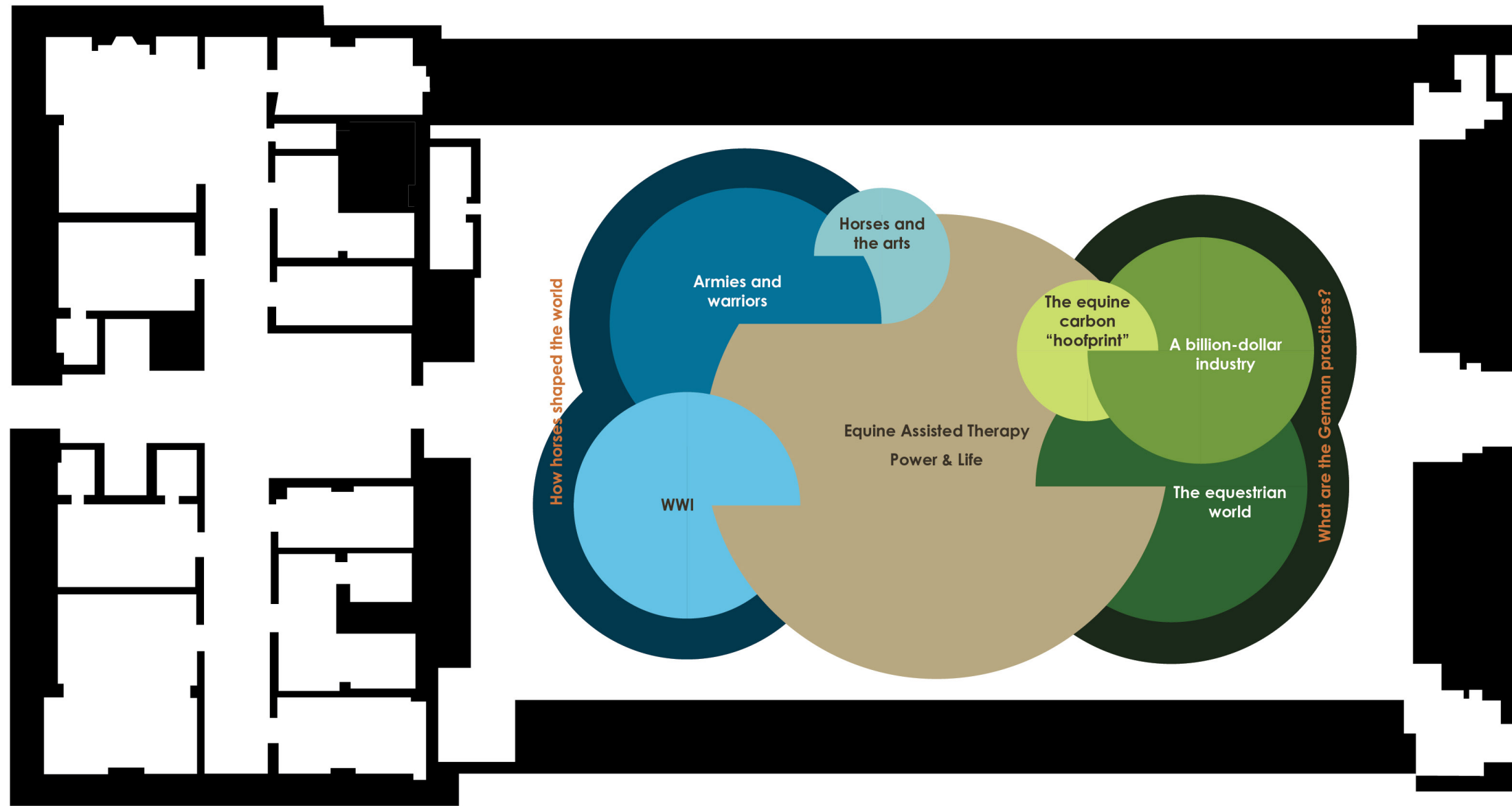



PROJECT
HORSECENTRISM
THESIS CAPSTONE
EXHIBIT

DRAWN BY
FLAVIA PEDROSA TONIETTO

SITE
**PARK AVENUE ARMORY
NEW YORK**



KEY PLAN

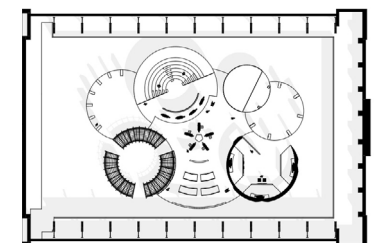

NOTES
DRAWINGS FOR
DESIGN INTENT
ONLY

DRAWING
CONCEPT ON PLAN

SCALE
NTS

DRAWING NO
EX1.11

DATE
DEC.06.2023

* OPEN FLOOR PLAN

** 55,000 FT²

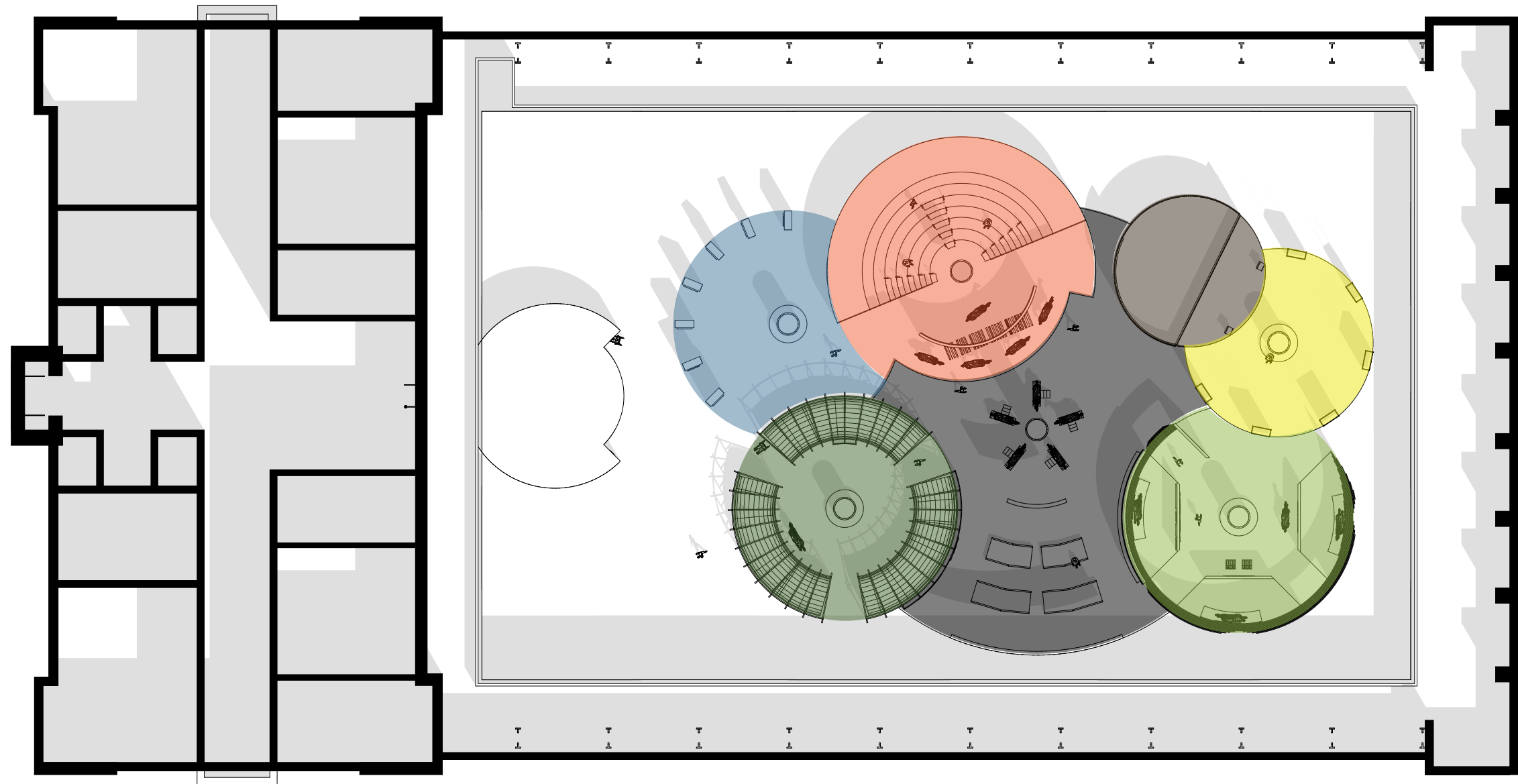



PROJECT
HORSECENTRISM
THESIS CAPSTONE
EXHIBIT

DRAWN BY
FLAVIA PEDROSA TONIETTO

SITE
**PARK AVENUE ARMORY
NEW YORK**

CLIENTS



KEY PLAN

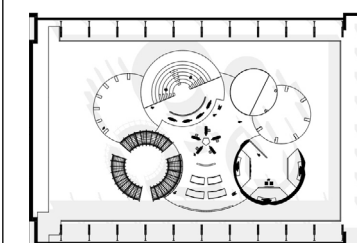

NOTES
DRAWINGS FOR
DESIGN INTENT
ONLY

DRAWING
EXPERIENCE DESCRIPTION

SCALE
NTS

DRAWING NO
EX1.12

DATE
DEC.06.2023

EXPERIENCE DESCRIPTION

Three types of wayfinding were developed in the vicinity of the Park Avenue Armory to guide visitors to the exhibit. The first wayfinding is the footprints of a horse and a man walking side by side, located on two corners, starting from the 68 St-Hunter College metro station. The second wayfinding, a metal structure with the logo, directs visitors to the building's entrance and is located in the corners of the block. And finally the third wayfinding, there are four giant banners located on the facade of the Park Avenue Armory.

Upon entering the exhibition, visitors will be exposed to an introductory video that will briefly describe each area, this way visitors will have an idea of the content they will be exposed to. After the introductory video, visitors will be able to move freely around the space. Through an open floor plan, my objective was to encourage visitor participation regarding a menu of possible circulation routes, so visitors can choose what they want to see. Furthermore, a transparent layout, with as few dividers as possible, allows visitors to better understand the relationship between the exhibits. Among the seven topics developed, the main one, Equine Therapy, is located in the center, dividing the others into two groups of three. The areas are visibly identified, through colors and a central cylinder that, in addition to having the name of the key concept, also has seats. The objective is to make visitors read these elements as points of reference, identifying them as distinct areas with different content.

00A: WAYFINDING RENDER



PROJECT
HORSECENTRISM
THESIS CAPSTONE
EXHIBIT

DRAWN BY
FLAVIA PEDROSA TONIETTO

SITE
**PARK AVENUE ARMORY
NEW YORK**



KEY PLAN

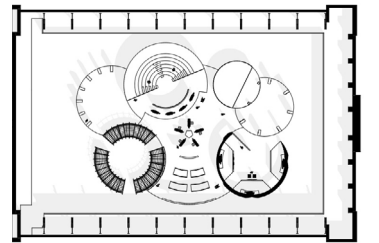

NOTES
DRAWINGS FOR
DESIGN INTENT
ONLY

DRAWING
WAYFINDING RENDER

SCALE
NTS

DRAWING NO
EX1.13

DATE
DEC.06.2023

00A: WAYFINDING RENDER



PROJECT
HORSECENTRISM
THESIS CAPSTONE
EXHIBIT

DRAWN BY
FLAVIA PEDROSA TONIETTO

SITE
**PARK AVENUE ARMORY
NEW YORK**



KEY PLAN

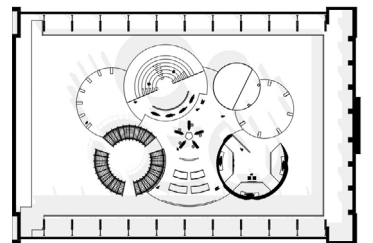

NOTES
DRAWINGS FOR
DESIGN INTENT
ONLY

DRAWING
WAYFINDING RENDER

SCALE
NTS

DRAWING NO
EX1.14

DATE
DEC.06.2023

00A: WAYFINDING RENDER



PROJECT
HORSECENTRISM
THESIS CAPSTONE
EXHIBIT

DRAWN BY
FLAVIA PEDROSA TONIETTO

SITE
**PARK AVENUE ARMORY
NEW YORK**



KEY PLAN

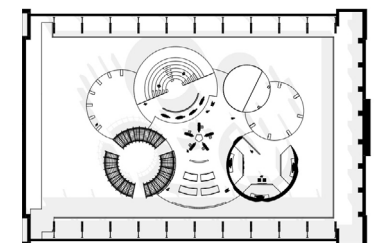

NOTES
DRAWINGS FOR
DESIGN INTENT
ONLY

DRAWING
WAYFINDING RENDER

SCALE
NTS

DRAWING NO
EX1.15

DATE
DEC.06.2023

00B: AXONOMETRIC

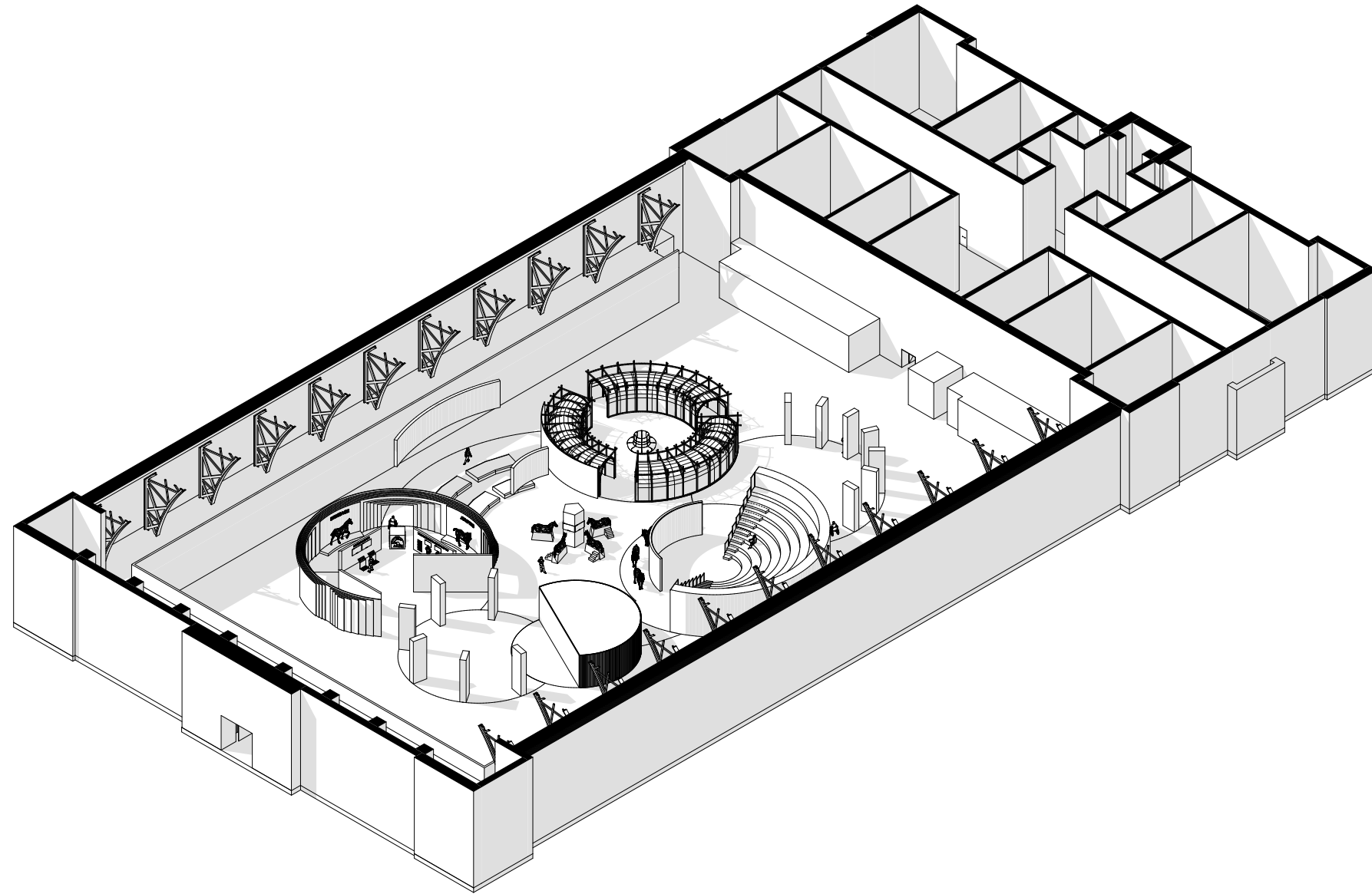

PROJECT
HORSECENTRISM
THESIS CAPSTONE
EXHIBIT

DRAWN BY
FLAVIA PEDROSA TONIETTO

SITE
**PARK AVENUE ARMORY
NEW YORK**

CLIENTS



KEY PLAN

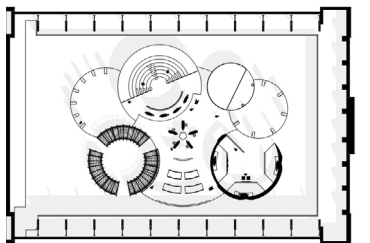

NOTES
DRAWINGS FOR
DESIGN INTENT
ONLY

DRAWING
00B AXONOMETRIC

SCALE
NTS

DRAWING NO
EX1.16

DATE
DEC.06.2023

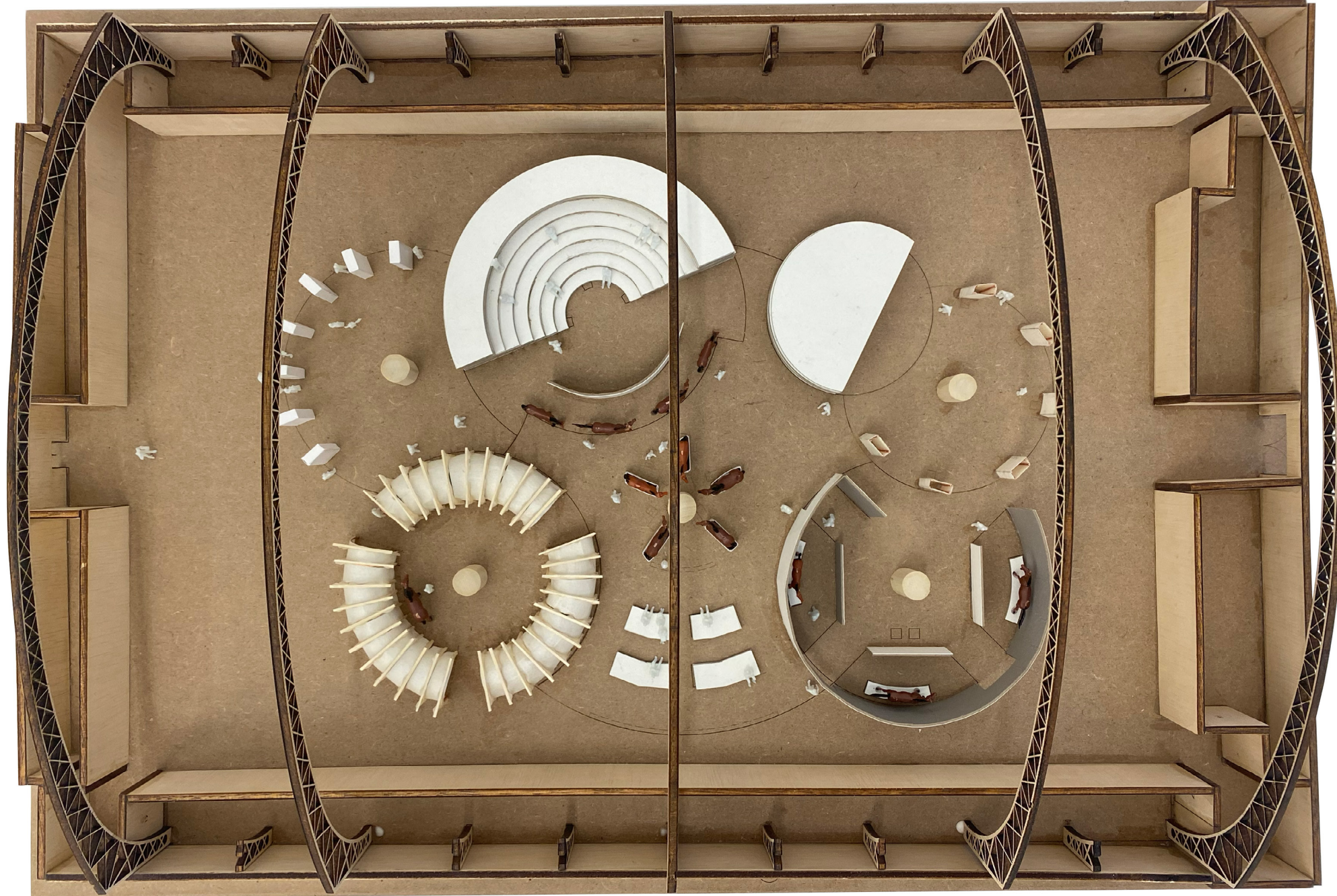

PROJECT
HORSECENTRISM
THESIS CAPSTONE
EXHIBIT

DRAWN BY
FLAVIA PEDROSA TONIETTO

SITE
**PARK AVENUE ARMORY
NEW YORK**

CLIENTS



KEY PLAN

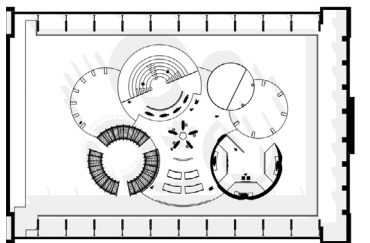

NOTES
DRAWINGS FOR
DESIGN INTENT
ONLY

DRAWING
MODEL

SCALE
NTS

DRAWING NO
ex1.17

DATE
DEC.06.2023



PROJECT
HORSECENTRISM
THESIS CAPSTONE
EXHIBIT

DRAWN BY
FLAVIA PEDROSA TONIETTO

SITE
**PARK AVENUE ARMORY
NEW YORK**



KEY PLAN

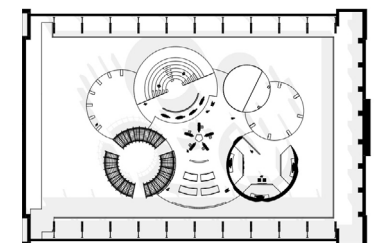

NOTES
DRAWINGS FOR
DESIGN INTENT
ONLY

DRAWING
MODEL CONT'D

SCALE
NTS

DRAWING NO
EX1.18

DATE
DEC.06.2023





PROJECT
HORSECENTRISM
THESIS CAPSTONE
EXHIBIT

DRAWN BY
FLAVIA PEDROSA TONIETTO

SITE
**PARK AVENUE ARMORY
NEW YORK**



KEY PLAN

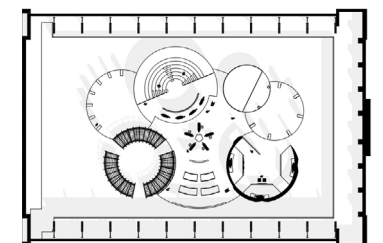

NOTES
DRAWINGS FOR
DESIGN INTENT
ONLY

DRAWING
MODEL CONT'D

SCALE
NTS

DRAWING NO
EX1.19

DATE
DEC.06.2023



PROJECT
HORSECENTRISM
THESIS CAPSTONE
EXHIBIT

DRAWN BY
FLAVIA PEDROSA TONIETTO

SITE
**PARK AVENUE ARMORY
NEW YORK**



KEY PLAN

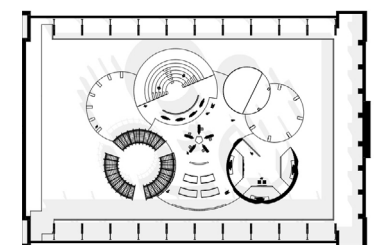

NOTES
DRAWINGS FOR
DESIGN INTENT
ONLY

DRAWING
MODEL CONT'D

SCALE
NTS

DRAWING NO
EX1.20

DATE
DEC.06.2023





PROJECT
HORSECENTRISM
THESIS CAPSTONE
EXHIBIT

DRAWN BY
FLAVIA PEDROSA TONIETTO

SITE
**PARK AVENUE ARMORY
NEW YORK**



KEY PLAN

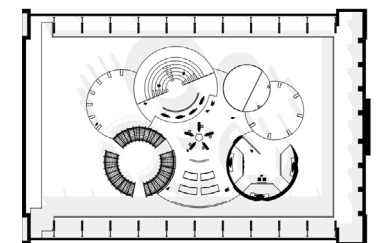

NOTES
DRAWINGS FOR
DESIGN INTENT
ONLY

DRAWING
01B EXPERIENCE DESCRIPTION

SCALE
NTS

DRAWING NO
EX1.21

DATE
DEC.06.2023

ARMIES AND WARRIORS

After the introductory video, upon entering the exhibition, visitors will be closer to Armies and Warriors, which consists of seven vertical blocks, arranged in a circle, which contain dioramas of important battles and their respective warriors and armies, such as Hernán Cortes, Napoleon Bonaparte, Genghis Khan, Alexander The Great, Attila The Hun, Roman Empire, and Battle of Poitiers. Each display can be seen on both sides of the vertical block, thus allowing the visitor to have visual access from more than one angle. Visitors will learn through the scenes how unequal a battle can be when one side has horses and the other does not, but most importantly that the horse helped to forge the image of great warriors.



PROJECT
HORSECENTRISM
THESIS CAPSTONE
EXHIBIT

DRAWN BY
FLAVIA PEDROSA TONIETTO

SITE
**PARK AVENUE ARMORY
NEW YORK**



KEY PLAN

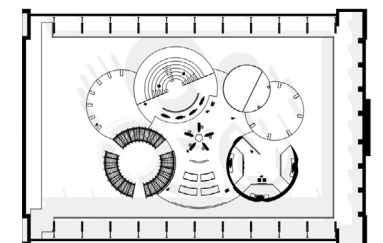

NOTES
DRAWINGS FOR
DESIGN INTENT
ONLY

DRAWING
01B RENDER

SCALE
NTS

DRAWING NO
EX1.22

DATE
DEC.06.2023



PROJECT
HORSECENTRISM
THESIS CAPSTONE
EXHIBIT

DRAWN BY
FLAVIA PEDROSA TONIETTO

SITE
**PARK AVENUE ARMORY
NEW YORK**



KEY PLAN

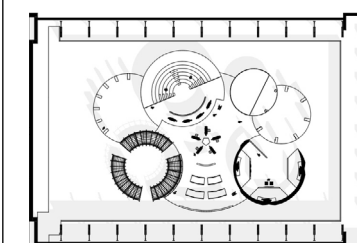

NOTES
DRAWINGS FOR
DESIGN INTENT
ONLY

DRAWING
02B EXPERIENCE DESCRIPTION

SCALE
NTS

DRAWING NO
EX1.23

DATE
DEC.06.2023

WWI

Next to Armies and Warriors is the First World War Tunnel, which consists of a circular tunnel with three entrances made of fabric. The exterior of the tunnel is surrounded by a thin wooden structure that resembles the idea of trenches. The tunnel is divided into three parts: the participation of the horses before, during, and after the war, which corresponds to the collection of horses from all over the world, the work of the horses in the war, and the auction of the horses after the war. Videos corresponding to each of the three phases are projected on the tunnel walls, and sounds narrating these moments are also available to visitors when walking through or near the tunnels. My intention is to provide an immersive experience so that visitors will understand the role of horses in the First World War, and consequently have empathy for the work carried out by horses.



PROJECT
HORSECENTRISM
THESIS CAPSTONE
EXHIBIT

DRAWN BY
FLAVIA PEDROSA TONIETTO

SITE
**PARK AVENUE ARMORY
NEW YORK**

CLIENTS



KEY PLAN

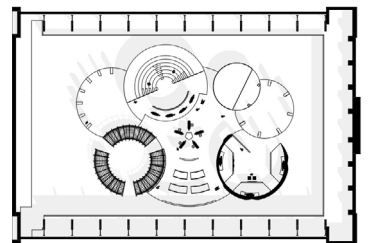

NOTES
DRAWINGS FOR
DESIGN INTENT
ONLY

DRAWING
02B RENDER

SCALE
NTS

DRAWING NO
EX1.24

DATE
DEC.06.2023



PROJECT
HORSECENTRISM
THESIS CAPSTONE
EXHIBIT

DRAWN BY
FLAVIA PEDROSA TONIETTO

SITE
**PARK AVENUE ARMORY
NEW YORK**

CLIENTS



KEY PLAN

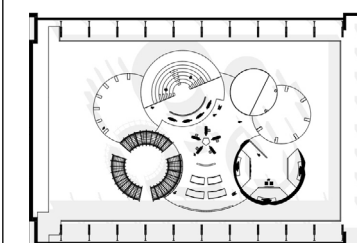

NOTES
DRAWINGS FOR
DESIGN INTENT
ONLY

DRAWING
03B EXPERIENCE DESCRIPTION

SCALE
NTS

DRAWING NO
EX1.25

DATE
DEC.06.2023

HORSES AND THE ARTS

This area has three activities that take place in an amphitheater. The first is War Horse Performance, a show that uses life-size horse puppets, which are manipulated by at least three actors. The amphitheater serves as a bleacher for visitors.

The second activity is Cave Paintings of horses, which take place under the bleacher. It consists of a semicircular tunnel that has extruded drawings of horses made in caves on one side, and on the other side, there is paper for people to make their own drawings of horses. When the paper is full of drawings it is rolled up and a new surface of paper without drawings is exposed.

The third activity is Life-Size Horse Puppet Workshop, which takes place on the opposite side of the amphitheater stage, where four puppets, identical to those used in the War Horse Performance, are available to visitors so they can handle them. For each puppet, at least three people are required, therefore, the activity seeks to encourage the participation of visitors even if they do not belong to the same group. Additionally, visitors will learn about horses' body language. This activity is supervised by an exhibition team and takes place using passwords with timetables that are distributed to interested visitors.

Through the three activities, visitors will learn that horses have been part of human lives for a long time and understand that this relationship has been transforming to the point of generating balance and respect for humans and horses.



PROJECT
HORSECENTRISM
THESIS CAPSTONE
EXHIBIT

DRAWN BY
FLAVIA PEDROSA TONIETTO

SITE
**PARK AVENUE ARMORY
NEW YORK**



KEY PLAN

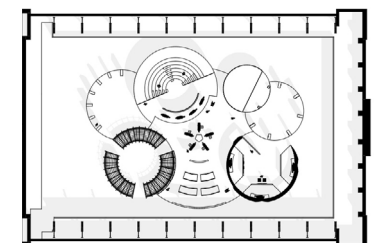

NOTES
DRAWINGS FOR
DESIGN INTENT
ONLY

DRAWING
03B AMPHITHEATER RENDER

SCALE
NTS

DRAWING NO
EX1.26

DATE
DEC.06.2023



PROJECT
HORSECENTRISM
THESIS CAPSTONE
EXHIBIT

DRAWN BY
FLAVIA PEDROSA TONIETTO

SITE
**PARK AVENUE ARMORY
NEW YORK**



KEY PLAN

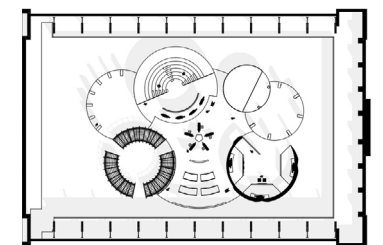

NOTES
DRAWINGS FOR
DESIGN INTENT
ONLY

DRAWING
03B CAVE PAINTINGS RENDER

SCALE
NTS

DRAWING NO
EX1.27

DATE
DEC.06.2023



PROJECT
HORSECENTRISM
THESIS CAPSTONE
EXHIBIT

DRAWN BY
FLAVIA PEDROSA TONIETTO

SITE
**PARK AVENUE ARMORY
NEW YORK**

CLIENTS



KEY PLAN

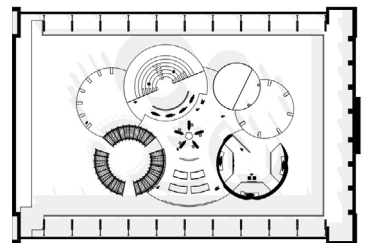

NOTES
DRAWINGS FOR
DESIGN INTENT
ONLY

DRAWING
03B PUPPET WORKSHOP RENDER

SCALE
NTS

DRAWING NO
EX1.28

DATE
DEC.06.2023



PROJECT
HORSECENTRISM
THESIS CAPSTONE
EXHIBIT

DRAWN BY
FLAVIA PEDROSA TONIETTO

SITE
**PARK AVENUE ARMORY
NEW YORK**

CLIENTS



KEY PLAN

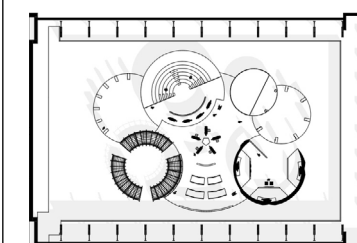

NOTES
DRAWINGS FOR
DESIGN INTENT
ONLY

DRAWING
04B EXPERIENCE DESCRIPTION

SCALE
NTS

DRAWING NO
EX1.29

DATE
DEC.06.2023

THE EQUESTRIAN WORLD

The Equestrian World also has three activities that mainly seek to awaken people's competitive side. The first is What Horses Can and Cannot Eat, which can be played individually or in pairs. The objective is to get eight of the sixteen available foods right first. Participants have turns and they must take the food from the wall, scan it in the horse's mouth and place it back. On the wall, red luminous numbers represent the wrong foods, while green luminous numbers represent the correct foods.

The second activity is Horses in Motion. The objective is to reproduce the horse's gaits: walk, trot, and canter, in that order using the hands and feet. Lights light up on the surfaces representing the hands and feet as the participant touches them. Whoever manages to reproduce the movements first wins. This activity can also be played individually.

The third activity is Grooming the Horse, it can be carried out individually and is educational in nature. The visitor learns how to clean the horse, using the correct tools and movements, in the correct sequence.

All three activities seek to teach visitors how to handle horses, and the appropriate foods, in addition to understanding the horse's mechanics, which is extremely important when practicing sports.



PROJECT
HORSECENTRISM
THESIS CAPSTONE
EXHIBIT

DRAWN BY
FLAVIA PEDROSA TONIETTO

SITE
**PARK AVENUE ARMORY
NEW YORK**



KEY PLAN

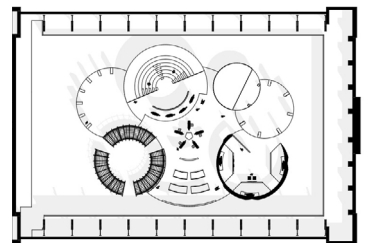

NOTES
DRAWINGS FOR
DESIGN INTENT
ONLY

DRAWING
04B RENDER

SCALE
NTS

DRAWING NO
EX1.30

DATE
DEC.06.2023



PROJECT
HORSECENTRISM
THESIS CAPSTONE
EXHIBIT

DRAWN BY
FLAVIA PEDROSA TONIETTO

SITE
**PARK AVENUE ARMORY
NEW YORK**



KEY PLAN

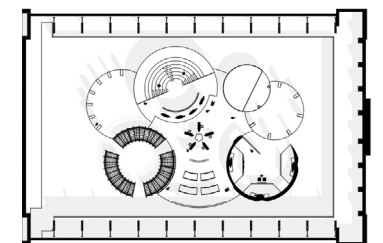

NOTES
DRAWINGS FOR
DESIGN INTENT
ONLY

DRAWING
05B EXPERIENCE DESCRIPTION

SCALE
NTS

DRAWING NO
EX1.31

DATE
DEC.06.2023

A BILLION-DOLLAR INDUSTRY

In this area, visitors will see six vertical rectangular elements made of fabric positioned in a circle. Each element represents an area of the equestrian industry: food, equipment, instructors, veterinarians, farriers, and horse breeders. One side of the blocks contains the name of the activity, through a gobo light, while on the other surface a video about the economic activity carried out is projected. Through this information, visitors will be able to understand how economically relevant the equine industry is, representing billions of dollars.



PROJECT
HORSECENTRISM
THESIS CAPSTONE
EXHIBIT

DRAWN BY
FLAVIA PEDROSA TONIETTO

SITE
**PARK AVENUE ARMORY
NEW YORK**



KEY PLAN

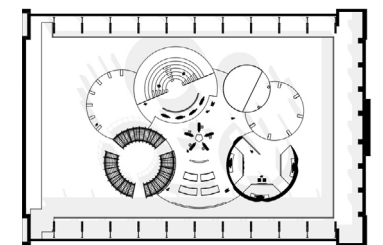

NOTES
DRAWINGS FOR
DESIGN INTENT
ONLY

DRAWING
05B RENDER

SCALE
NTS

DRAWING NO
EX1.32

DATE
DEC.06.2023



PROJECT
HORSECENTRISM
THESIS CAPSTONE
EXHIBIT

DRAWN BY
FLAVIA PEDROSA TONIETTO

SITE
**PARK AVENUE ARMORY
NEW YORK**



KEY PLAN

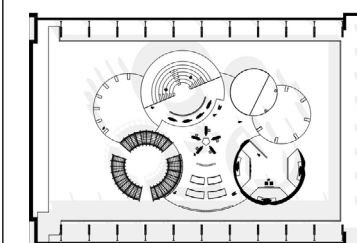

NOTES
DRAWINGS FOR
DESIGN INTENT
ONLY

DRAWING
06B EXPERIENCE DESCRIPTION

SCALE
NTS

DRAWING NO
EX1.33

DATE
DEC.06.2023

THE EQUINE CARBON “HOOFPRIINT”

This area consists of a semi-circular projection room, in which visitors can sit on chairs to learn about the case study of a stable in Sweden. The stable is called Lövsta Stuteri, which works in partnership with researchers from Wageningen University in the Netherlands to develop tools capable of measuring CO₂ emissions. The stable has an average of one hundred high-performance horses and has a management system focused on sustainable practices, such as: measuring the consumption of energy, water, and manure, sorting waste, reducing consumption, and purchasing environmentally friendly goods, in addition, the establishment has developed an award to encourage the best environmental initiative in Sweden and in the US to support different organizations.

On the outside wall of the projection room, there is an interactive panel called Sharing Your Sustainable Actions that invites visitors to share sustainable initiatives, through two interfaces located in front of the panel. The objective is to share information and thus teach and motivate visitors to adopt sustainable practices.



PROJECT
HORSECENTRISM
THESIS CAPSTONE
EXHIBIT

DRAWN BY
FLAVIA PEDROSA TONIETTO

SITE
**PARK AVENUE ARMORY
NEW YORK**



KEY PLAN

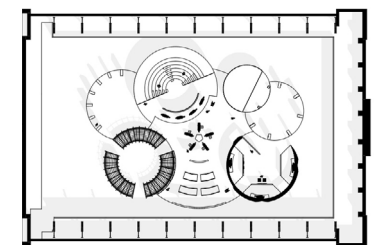

NOTES
DRAWINGS FOR
DESIGN INTENT
ONLY

DRAWING
06B PROJECTION ROOM RENDER

SCALE
NTS

DATE
DEC.06.2023

DRAWING NO
EX1.34



PROJECT
HORSECENTRISM
THESIS CAPSTONE
EXHIBIT

DRAWN BY
FLAVIA PEDROSA TONIETTO

SITE
**PARK AVENUE ARMORY
NEW YORK**



KEY PLAN

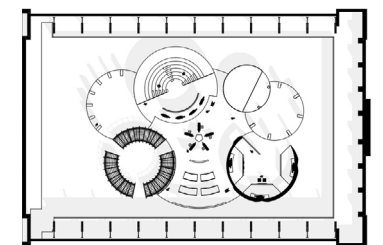

NOTES
DRAWINGS FOR
DESIGN INTENT
ONLY

DRAWING
06B SHARING PANEL RENDER

SCALE
NTS

DRAWING NO
EX1.35

DATE
DEC.06.2023



PROJECT
HORSECENTRISM
THESIS CAPSTONE
EXHIBIT

DRAWN BY
FLAVIA PEDROSA TONIETTO

SITE
**PARK AVENUE ARMORY
NEW YORK**

CLIENTS



KEY PLAN

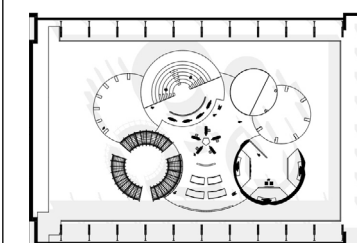

NOTES
DRAWINGS FOR
DESIGN INTENT
ONLY

DRAWING
07B EXPERIENCE DESCRIPTION

SCALE
NTS

DRAWING NO
EX1.36

DATE
DEC.06.2023

THE EQUINE-ASSISTED THERAPY: POWER & LIFE

In this area there are two main activities, the first is the Equine Therapy Simulator, which consists of five horse simulators arranged radially around a cylinder. Each simulator will be assisted by two people, one who controls the horse simulator and a therapist who accompanies the visitor on the horse's side. The horse simulator reproduces equine- assisted therapy in a more controlled way, providing the visitor with an approximate experience of the therapy. Each session lasts an average of six minutes and interested visitors receive a timed ticket to avoid queues.

The second activity consists of projecting testimonials from equine therapy patients on a semicircular screen hanging from the ceiling. Visitors will be able to sit or lie down on the ottoman seats, feeling comfortable to watch the testimonies. The audio can be accessed through QR codes on visitors' cell phones, or provided through headphones at the exhibition. Through patient testimonials, visitors will learn how relevant and transformative equine therapy is, and will thus share the information or even be interested in bringing it into their lives.



PROJECT
HORSECENTRISM
THESIS CAPSTONE
EXHIBIT

DRAWN BY
FLAVIA PEDROSA TONIETTO

SITE
**PARK AVENUE ARMORY
NEW YORK**



KEY PLAN

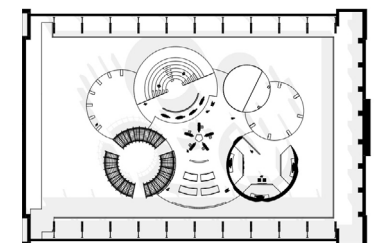

NOTES
DRAWINGS FOR
DESIGN INTENT
ONLY

DRAWING
07B HORSE SIMULATOR RENDER

SCALE
NTS

DRAWING NO
EX1.37

DATE
DEC.06.2023



PROJECT
HORSECENTRISM
THESIS CAPSTONE
EXHIBIT

DRAWN BY
FLAVIA PEDROSA TONIETTO

SITE
**PARK AVENUE ARMORY
NEW YORK**



KEY PLAN

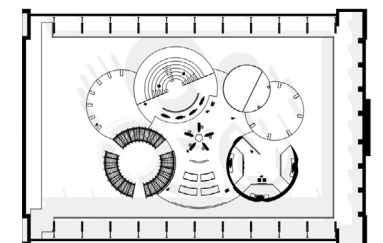

NOTES
DRAWINGS FOR
DESIGN INTENT
ONLY

DRAWING
07B TESTIMONIALS RENDER

SCALE
NTS

DRAWING NO
EX1.38

DATE
DEC.06.2023



PROJECT
HORSECENTRISM
THESIS CAPSTONE
EXHIBIT

DRAWN BY
FLAVIA PEDROSA TONIETTO

SITE
**PARK AVENUE ARMORY
NEW YORK**



KEY PLAN

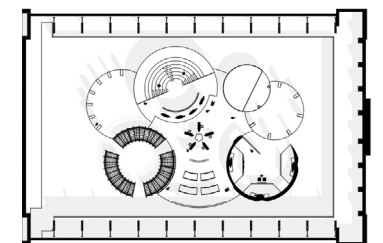

NOTES
DRAWINGS FOR
DESIGN INTENT
ONLY

DRAWING
DURATION & STAFF ROLES

SCALE
1"=30'

DATE
DEC.06.2023

DRAWING NO
EX1.39

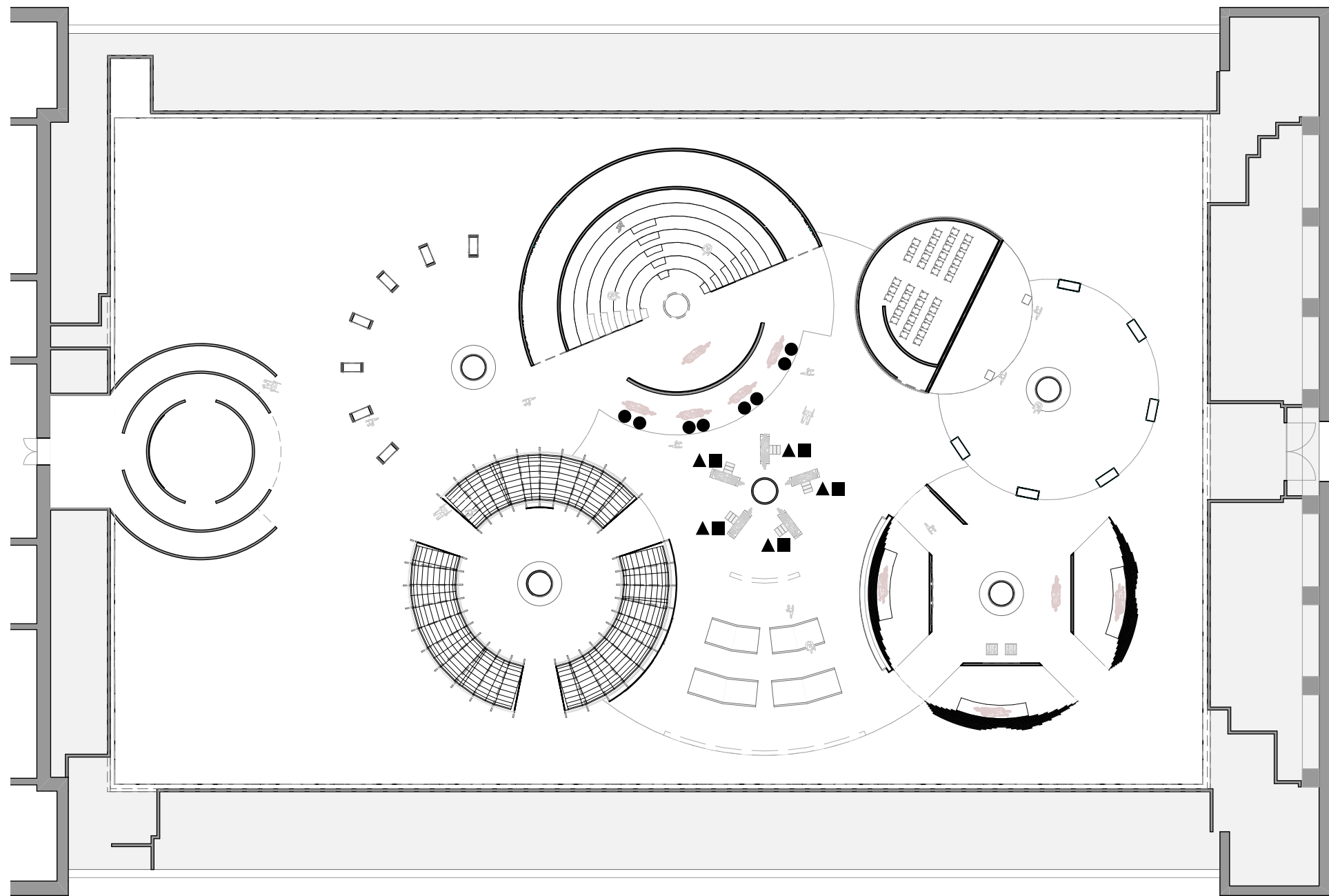

LEGEND:

- ▲ ECOTHERAPIST
- HORSE SIMULATOR CONTROLER
- PUPPET COORDINATOR

THE PROFESSIONALS ARE
DIVIDED INTO TWO GROUPS
THAT ROTATE EVERY HOUR.

1 DURATION & STAFF ROLES
scale: 1"=30'



PROJECT
HORSECENTRISM
THESIS CAPSTONE
EXHIBIT

DRAWN BY
FLAVIA PEDROSA TONIETTO

SITE
**PARK AVENUE ARMORY
NEW YORK**



KEY PLAN

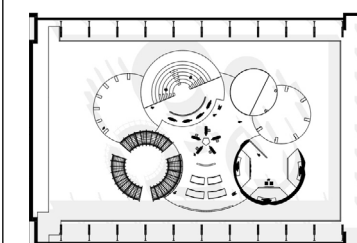

NOTES
DRAWINGS FOR
DESIGN INTENT
ONLY

DRAWING
POST VISIT ENGAGEMENT

SCALE
NTS

DRAWING NO
EX1.40

DATE
DEC.06.2023

POST VISIT ENGAGEMENT

Scanning the QR code, visitors will have access to three options: the first is to schedule an equine therapy session at one of the establishments that partner with PATH International, the second option is to access the PATH International website to search for information regarding certification of the practice of equine therapy and the third and final option is to access the German Equestrian Federation website.

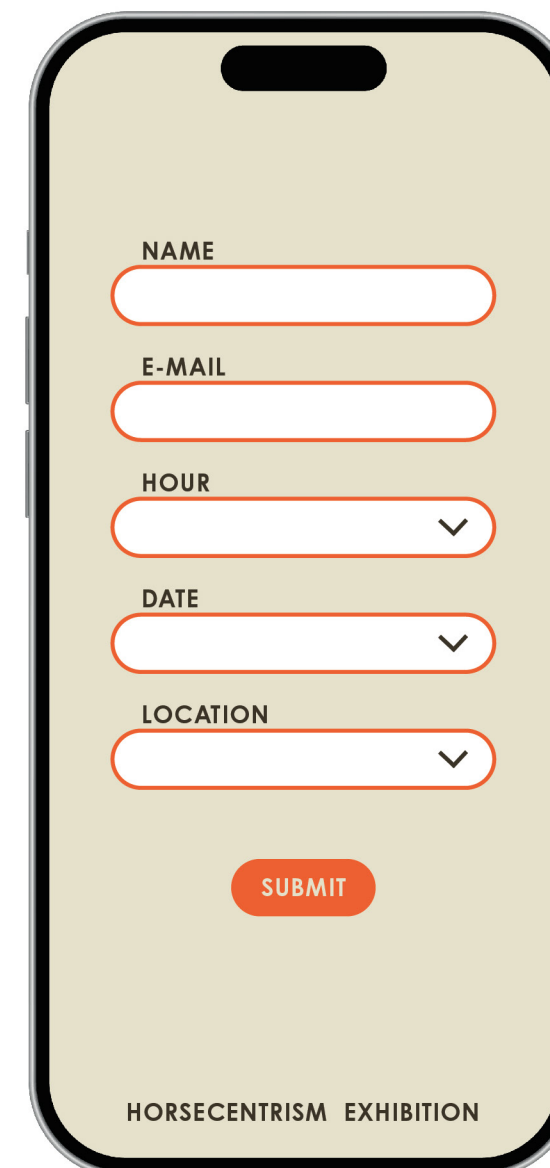
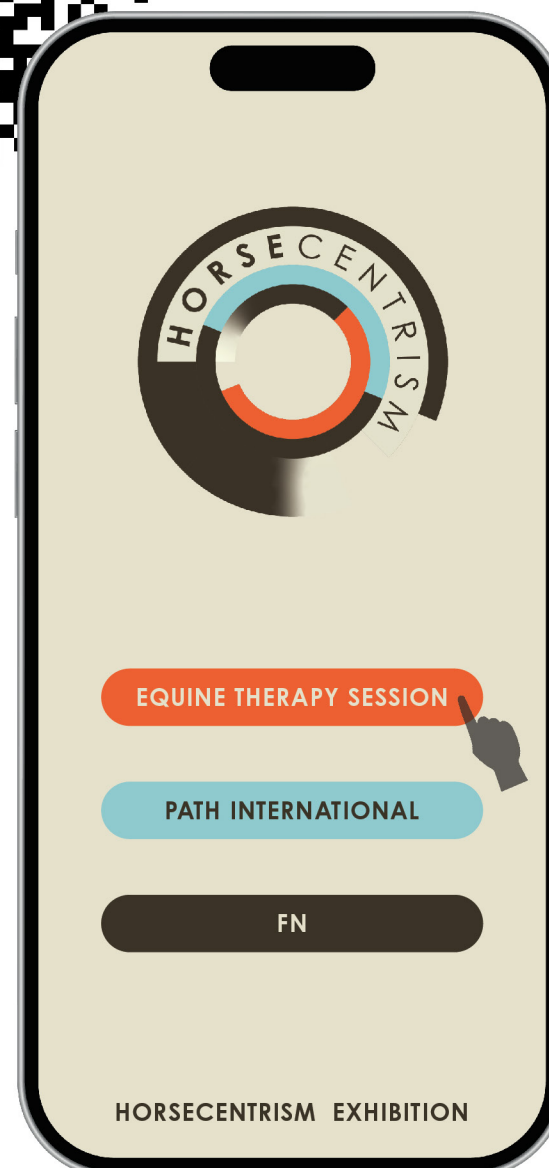

SCHEDULES & LISTS

GRAPHIC SCHEDULE

SECTION 00A

CODE	SIGN TYPE	DESCRIPTION
00A.01	A	WAYFINDING FACADE BANNER
00A.02	A	WAYFINDING FACADE BANNER
00A.03	A	WAYFINDING FACADE BANNER
00A.04	A	WAYFINDING FACADE BANNER
00A.05	B	FREESTANDING DIRECTIONAL WAYFINDING
00A.06	B	FREESTANDING DIRECTIONAL WAYFINDING
00A.07	B	FREESTANDING DIRECTIONAL WAYFINDING
00A.08	B	FREESTANDING DIRECTIONAL WAYFINDING
00A.09	C	EXTERIOR DIRECTIONAL FLOOR GRAPHIC
00A.10	C	EXTERIOR DIRECTIONAL FLOOR GRAPHIC
00A.11	C	EXTERIOR DIRECTIONAL FLOOR GRAPHIC
00A.12	C	INTERIOR FLOOR GRAPHIC
00A.13	C	INTERIOR FLOOR GRAPHIC
00A.14	C	INTERIOR FLOOR GRAPHIC

SECTION 00B

00B.01	D	INTRODUCTION LOGO
--------	---	-------------------

SECTION 01B

01B.01	E	INTRODUCTION TITLE
01B.02.GR01	D	MEDIUM EXTRUDED CONCENTRIC SEMICIRCLES
01B.02.GR02	F	DIMENSIONAL LETTERS
01B.03.GR01	D	MEDIUM EXTRUDED CONCENTRIC SEMICIRCLES



PROJECT
HORSECENTRISM
THESIS CAPSTONE
EXHIBIT

DRAWN BY
FLAVIA PEDROSA TONIETTO

SITE
**PARK AVENUE ARMORY
NEW YORK**

CLIENTS



KEY PLAN

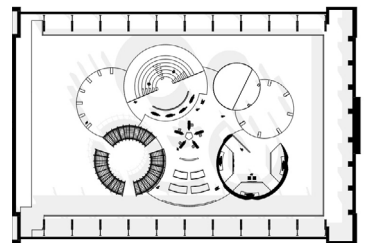

NOTES
DRAWINGS FOR
DESIGN INTENT
ONLY

DRAWING
GRAPHIC SCHEDULE

SCALE
NTS

DRAWING NO
EX2.01

DATE
DEC.06.2023



PROJECT
HORSECENTRISM
THESIS CAPSTONE
EXHIBIT

DRAWN BY
FLAVIA PEDROSA TONIETTO

SITE
**PARK AVENUE ARMORY
NEW YORK**

CLIENTS



KEY PLAN

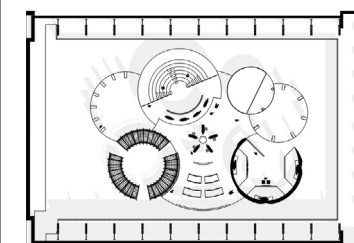

NOTES
DRAWINGS FOR
DESIGN INTENT
ONLY

DRAWING
GRAPHIC SCHEDULE
CONT'D

SCALE
NTS

DRAWING NO
EX2.02

DATE
DEC.06.2023

01B.03.GR02	F	DIMENSIONAL LETTERS
01B.04.GR01	D	MEDIUM EXTRUDED CONCENTRIC SEMICIRCLES
01B.04.GR02	F	DIMENSIONAL LETTERS
01B.05.GR01	D	MEDIUM EXTRUDED CONCENTRIC SEMICIRCLES
01B.05.GR02	F	DIMENSIONAL LETTERS
01B.06.GR01	D	MEDIUM EXTRUDED CONCENTRIC SEMICIRCLES
01B.06.GR02	F	DIMENSIONAL LETTERS
01B.07.GR01	D	MEDIUM EXTRUDED CONCENTRIC SEMICIRCLES
01B.07.GR02	F	DIMENSIONAL LETTERS
01B.08.GR01	D	MEDIUM EXTRUDED CONCENTRIC SEMICIRCLES
01B.08.GR02	F	DIMENSIONAL LETTERS

SECTION 02B

02B.01 **E** INTRODUCTION TITLE

SECTION 03B

03B.01 **E** INTRODUCTION TITLE

03B.02 **F** DIMENSIONAL LETTERS

03B.03.GR01 **G** SCULPTED HIGH DENSITY FOAM MADE BY A SCENIC ARTIST

03B.03.GR02 **D** ACRYLIC HORSE SHAPES 1/4" THICKNESS

SECTION 04B

04B.01 **E** INTRODUCTION TITLE



PROJECT
HORSECENTRISM
THESIS CAPSTONE
EXHIBIT

DRAWN BY
FLAVIA PEDROSA TONIETTO

SITE
**PARK AVENUE ARMORY
NEW YORK**

CLIENTS



KEY PLAN

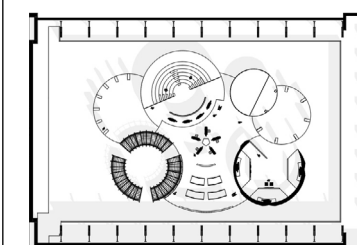

NOTES
DRAWINGS FOR
DESIGN INTENT
ONLY

DRAWING
**GRAPHIC SCHEDULE
CONT'D**

SCALE
NTS

DRAWING NO
EX2.03

DATE
DEC.06.2023

04B.02.GR01	D	LARGE EXTRUDED CONCENTRIC SEMICIRCLES
04B.02.GR02	F	DIMENSIONAL LETTERS
04B.03.GR01	D	LARGE EXTRUDED CONCENTRIC SEMICIRCLES
04B.03.GR02	F	DIMENSIONAL LETTERS
04B.03.GR03	D	SMALL EXTRUDED CONCENTRIC SEMICIRCLES
04B.03.GR04	E	CIRCULAR PICTURE
04B.03.GR05	D	SMALL EXTRUDED CONCENTRIC SEMICIRCLES
04B.03.GR06	F	DIMENSIONAL LETTERS
04B.03.GR07	D	SMALL EXTRUDED CONCENTRIC SEMICIRCLES
04B.03.GR08	F	DIMENSIONAL LETTERS, OPPOSITE SIDE
04B.04.GR01	D	LARGE EXTRUDED CONCENTRIC SEMICIRCLES
04B.04.GR02	F	DIMENSIONAL LETTERS
04B.04.GR03	D	SMALL EXTRUDED CONCENTRIC SEMICIRCLES
04B.04.GR04	E	CIRCULAR PICTURE
04B.04.GR05	D	SMALL EXTRUDED CONCENTRIC SEMICIRCLES
04B.04.GR06	F	DIMENSIONAL LETTERS
04B.04.GR07	D	SMALL EXTRUDED CONCENTRIC SEMICIRCLES
04B.04.GR08	F	DIMENSIONAL LETTERS, OPPOSITE SIDE
04B.05.GR01	D	LARGE EXTRUDED CONCENTRIC SEMICIRCLES
04B.05.GR02	F	DIMENSIONAL LETTERS
04B.05.GR03	D	SMALL EXTRUDED CONCENTRIC SEMICIRCLES
04B.05.GR04	E	CIRCULAR PICTURE
04B.05.GR05	D	SMALL EXTRUDED CONCENTRIC SEMICIRCLES
04B.05.GR06	F	DIMENSIONAL LETTERS
04B.05.GR07	D	SMALL EXTRUDED CONCENTRIC SEMICIRCLES
04B.05.GR08	F	DIMENSIONAL LETTERS, OPPOSITE SIDE
04B.06.GR01	F	DIMENSIONAL LETTERS
04B.07.GR01	F	DIMENSIONAL LETTERS



PROJECT
HORSECENTRISM
THESIS CAPSTONE
EXHIBIT

DRAWN BY
FLAVIA PEDROSA TONIETTO

SITE
**PARK AVENUE ARMORY
NEW YORK**

CLIENTS



KEY PLAN

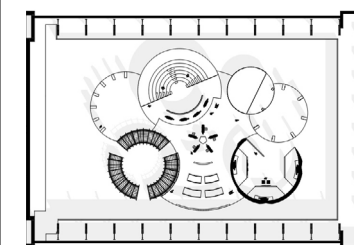

NOTES
DRAWINGS FOR
DESIGN INTENT
ONLY

DRAWING
**GRAPHIC SCHEDULE
CONT'D**

SCALE
NTS

DRAWING NO
EX2.04

DATE
DEC.06.2023

04B.08.GR01

F

DIMENSIONAL LETTERS

SECTION 05B

05B.01

E

INTRODUCTION TITLE

SECTION 06B

06B.01

E

INTRODUCTION TITLE

SECTION 07B

07B.01

E

INTRODUCTION TITLE

07B.02.GR01

H

EXHIBIT DISPLAY LABEL

07B.02.GR02

H

EXHIBIT DISPLAY LABEL

07B.02.GR03

H

EXHIBIT DISPLAY LABEL

07B.02.GR04

H

EXHIBIT DISPLAY LABEL

07B.02.GR05

H

EXHIBIT DISPLAY LABEL

07B.02.GR06

H

EXHIBIT DISPLAY LABEL

07B.02.GR07

H

EXHIBIT DISPLAY LABEL

07B.02.GR08

H

EXHIBIT DISPLAY LABEL

07B.02.GR09

H

EXHIBIT DISPLAY LABEL

07B.02.GR10

H

EXHIBIT DISPLAY LABEL

07B.02.GR11

H

EXHIBIT DISPLAY LABEL

07B.02.GR12

H

EXHIBIT DISPLAY LABEL

07B.02.GR13

H

EXHIBIT DISPLAY LABEL

07B.02.GR14

H

EXHIBIT DISPLAY LABEL

07B.02.GR15

H

EXHIBIT DISPLAY LABEL

07B.02.GR16

H

EXHIBIT DISPLAY LABEL

07B.02.GR17

H

EXHIBIT DISPLAY LABEL

07B.02.GR18

H

EXHIBIT DISPLAY LABEL

07B.02.GR19

H

EXHIBIT DISPLAY LABEL

07B.02.GR20	H	EXHIBIT DISPLAY LABEL
07B.02.GR21	H	EXHIBIT DISPLAY LABEL
07B.02.GR22	H	EXHIBIT DISPLAY LABEL
07B.02.GR23	H	EXHIBIT DISPLAY LABEL
07B.02.GR24	H	EXHIBIT DISPLAY LABEL
07B.02.GR25	H	EXHIBIT DISPLAY LABEL
07B.02.GR26	H	EXHIBIT DISPLAY LABEL
07B.02.GR27	H	EXHIBIT DISPLAY LABEL
07B.02.GR28	H	EXHIBIT DISPLAY LABEL
07B.02.GR29	H	EXHIBIT DISPLAY LABEL
07B.02.GR30	H	EXHIBIT DISPLAY LABEL
07B.03.GR01	D	PATH INTERNATIONAL EXTRUDED LOGO + QR CODE
07B.03.GR02	D	LARGE EXTRUDED CONCENTRIC SEMICIRCLES
07B.03.GR03	F	DIMENSIONAL LETTERS



PROJECT
HORSECENTRISM
THESIS CAPSTONE
EXHIBIT

DRAWN BY
FLAVIA PEDROSA TONIETTO

SITE
**PARK AVENUE ARMORY
NEW YORK**

CLIENTS



KEY PLAN

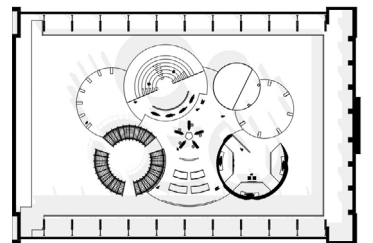

NOTES
DRAWINGS FOR
DESIGN INTENT
ONLY

DRAWING
**GRAPHIC SCHEDULE
CONT'D**

SCALE
NTS

DRAWING NO
EX2.05

DATE
DEC.06.2023

GRAPHIC SPECIFICATION LIST

SIGN TYPE

DESCRIPTION

A	EXTERIOR GRADE POLYESTER COATED FABRIC
B	POWDER-COATED ALUMINUM, 0.160" THICK
C	SURFACE ADHERED GRIT COATED EXTERIOR VINYL FLOOR GRAPHIC
D	MDF LAMINATE MATCHED PMS, THICKNESS ACCORDING TO DRAWINGS
E	HIGH RESOLUTION INK JET PRINTED VINYL DECAL
F	1/4" ACRYLIC DIMENSIONAL LETTER PAINTED MATCHED PMS
G	3M POLYSTYRENE FOAM 78 SPRAY TO EMULATE CAVE TEXTURE
H	1/8" BLACK ACRYLITE® SATINICE PANELS, BLIND FASTENERS, DIRECT PRINT SURFACE TYPE, LAMINATED



PROJECT
HORSECENTRISM
THESIS CAPSTONE EXHIBIT

DRAWN BY
FLAVIA PEDROSA TONIETTO

SITE
**PARK AVENUE ARMORY
NEW YORK**

CLIENTS



KEY PLAN

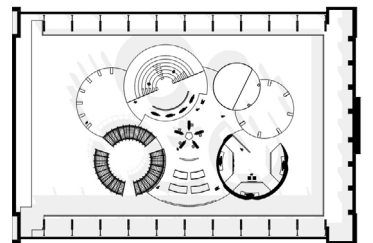

NOTES
DRAWINGS FOR DESIGN INTENT ONLY



DRAWING
GRAPHIC SPECIFICATION LIST

SCALE
NTS

DRAWING NO
EX2.06

DATE
DEC.06.2023

FINISH SCHEDULE

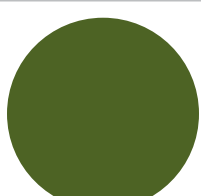
MATERIAL	CODE	DESCRIPTION	FINISH	LOCATION	THUMBNAIL
FABRIC	FB.01	SHEER WHITE FABRIC	—	ON THE PERIMETER OF THOMPSON HALL DRIL	
	FB.02	118" HALO, IFR PROJECTION FABRIC	TIGHT WEAVE TWILL	05B, 06B	
FABRIC STRUCTURE TUNNEL	FB.03	THE ORIGINATORS FABRIC SEE-SHELL TUNNEL 10'W X 10'H X 20'D	—	02B	
STEEL	ST.01	STEEL FRAME	GALVANIZED	00B, 03B, 04B, 06B	
WOOD	WD.01	1/2" THICK PINE LAMINATED MDF	WOOD VENEER	00B, 01B, 02B, 03B, 04B, 05B, 06B, 07B	
PAINT	PT.01	COLOR MATCH PANTONE 120-16C	COLOR WASHED	0B1	
	PT.02	COLOR MATCH PANTONE 159-16C	COLOR WASHED	0B2, 0B4	



PROJECT
HORSECENTRISM
THESIS CAPSTONE EXHIBIT

DRAWN BY
FLAVIA PEDROSA TONIETTO

SITE
**PARK AVENUE ARMORY
NEW YORK**

CLIENTS



KEY PLAN

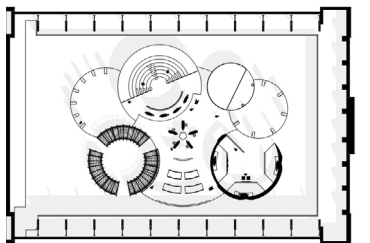

NOTES
DRAWINGS FOR
DESIGN INTENT
ONLY

DRAWING
FINISH SCHEDULE

SCALE
NTS

DATE
DEC.06.2023

DRAWING NO
EX2.07

MATERIAL	CODE	DESCRIPTION	FINISH	LOCATION	THUMBNAIL
PAINT	PT.03	COLOR MATCH PANTONE 37-8C	COLOR WASHED	0B3	
	PT.04	COLOR MATCH PANTONE 157-15C	COLOR WASHED	0B4	
	PT.05	COLOR MATCH PANTONE 158 -16C	COLOR WASHED	0B4	
	PT.06	COLOR MATCH PANTONE 3308 C	COLOR WASHED	0B4	
	PT.07	COLOR MATCH PANTONE 5535 C	COLOR WASHED	0B4	
	PT.08	COLOR MATCH PANTONE 166-8C	COLOR WASHED	0B5	
	PT.09	COLOR MATCH PANTONE 23-16C	COLOR WASHED	0B6	



PROJECT
HORSECENTRISM
THESIS CAPSTONE
EXHIBIT

DRAWN BY
FLAVIA PEDROSA TONIETTO

SITE
**PARK AVENUE ARMORY
NEW YORK**

CLIENTS



KEY PLAN

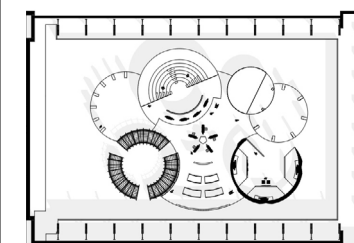





NOTES
DRAWINGS FOR
DESIGN INTENT
ONLY

DRAWING
FINISH SCHEDULE
CONT'D

SCALE
NTS

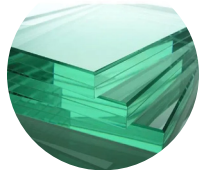
DRAWING NO
EX2.08

DATE
DEC.06.2023

MATERIAL	CODE	DESCRIPTION	FINISH	LOCATION	THUMBNAIL
LEATHER	LD.01	3/4 OZ LEATHER VEGETABLE-TANNED COWHIDE LEATHER	BROWN	07B	
GLASS	GL.01	LAMINATED GLASS	TRANLUCENT	07B	
VINYL	VL.01	BRUMARK VINYL PRINTED FLOOR	ASHLAND	07B	
	VL.02	BRUMARK VINYL PRINTED FLOOR	COLORADO	00B, 01B, 02B, 03B, 04B, 06B	
	VL.03	BRUMARK VINYL PRINTED FLOOR	YELLOW ASHLAND	05B	



PROJECT
HORSECENTRISM
THESIS CAPSTONE
EXHIBIT

DRAWN BY
FLAVIA PEDROSA TONIETTO

SITE
**PARK AVENUE ARMORY
NEW YORK**

CLIENTS



KEY PLAN

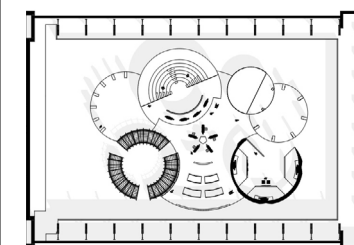

NOTES
DRAWINGS FOR
DESIGN INTENT
ONLY





DRAWING
**FINISH SCHEDULE
CONT'D**

SCALE
NTS

DRAWING NO
EX2.09

DATE
DEC.06.2023

AV SCHEDULE

CODE	TYPE	DESCRIPTION	MANUFACTURER	COMMENTS	THUMBNAIL
AV01	PROJECTOR	VPL-FHZ85 3LCD LASER PROJECTOR SONY, 474 W, 100-240 V, HDMI	SONY	N/A	
AV02	SPEAKER	CT 24-24 SONIC BEAM	BROWN	N/A	
AV03	TELEVISION	BRAVIA XR 65" CLASS A80L OLED 4K HDR	SONY	Model XR-65A80L	
AV04	TOUCHSCREEN	17 INCH TOUCHSCREEN METAL	BEETRONICS	FULL HD MULTI-TOUCH PANEL MODEL 17TS7M	



PROJECT
HORSECENTRISM
THESIS CAPSTONE
EXHIBIT

DRAWN BY
FLAVIA PEDROSA TONIETTO

SITE
**PARK AVENUE ARMORY
NEW YORK**

CLIENTS



KEY PLAN

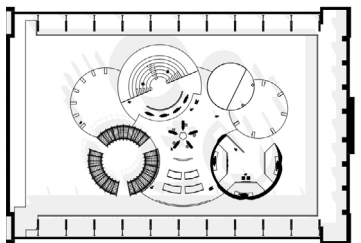

NOTES
DRAWINGS FOR
DESIGN INTENT
ONLY







DRAWING
AV SCHEDULE

SCALE
NTS

DRAWING NO
EX2.10

DATE
DEC.06.2023

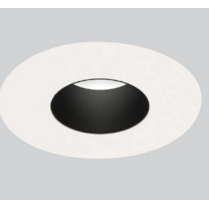
LIGHTING SCHEDULE

CODE	TYPE	DESCRIPTION	MANUFACTURER	WATTS	VOLTAGE	COMMENTS	THUMBNAIL
L1	LED	MICRO - M1RD HIGH OUTPUT 1.25" ROUND	USAI LIGHTING	7 W	120 V	BLACK MATTE 3000K COLOR TEMPERATURE 90+ CRI	
L2	LED	SPOTLIGHTS UNISCAN 120V	ERCO	21.6 W	120 V	BLACK 2700K COLOR TEMPERATURE 90+ CRI	
L3	LED	ATRIUM DOUBLE FOCUS	ERCO	74.1 W	0-10V DIMMABLE	BLACK POLYMER 2700K COLOR TEMPERATURE 90+ CRI	
L4	LED	BLAZE LED TAPE	DIODELED	50 W	12 V	2700K COLOR TEMPERATURE	
L5	LED	SLIVERLED ROUND DOWNLIGHT, 1" REGRESS — SR11	USAI LIGHTING	16 W	10 V	BLACK 3000K COLOR TEMPERATURE	
L6	LED	PANTRAC	ERCO	12 W	120 V	WHITE POLYMER 2700K COLOR TEMPERATURE	
L7	GOBO PROJECTOR	GOBOSIGN 40W INDOOR GOBO	GOBOSIGN	40 W	100-240 V	ALUMINIUM ALLOY BLACK	



PROJECT
HORSECENTRISM
THESIS CAPSTONE
EXHIBIT

DRAWN BY
FLAVIA PEDROSA TONIETTO

SITE
**PARK AVENUE ARMORY
NEW YORK**

CLIENTS



KEY PLAN

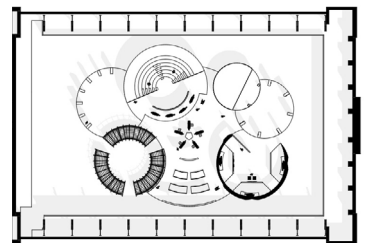

NOTES
DRAWINGS FOR
DESIGN INTENT
ONLY





DRAWING
LIGHTING SCHEDULE





SCALE
NTS

DATE
DEC.06.2023

DRAWING NO
EX2.11

OBJECT SCHEDULE

OBJECT	CODE	DESCRIPTION
	07A-01	DRESSAGE SADDLE
	07A-02	JUMPING SADDLE
	07A-03	BRIDLE
	07A-04	SINGLE-JOINTED BIT
	07A-05	DOUBLE-JOINTED BIT

OBJECT	CODE	DESCRIPTION
	07A-06	WEYMOUTH BIT
	07A-07	STIRRUPS
	07A-08	SPURS
	07A-09	DRESSAGE GIRTH
	07A-10	JUMP GIRTH



PROJECT
HORSECENTRISM
THESIS CAPSTONE
EXHIBIT

DRAWN BY
FLAVIA PEDROSA TONIETTO

SITE
**PARK AVENUE ARMORY
NEW YORK**



KEY PLAN

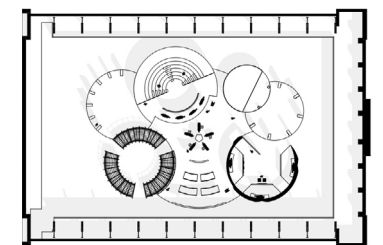

NOTES
DRAWINGS FOR
DESIGN INTENT
ONLY





DRAWING
OBJECT SCHEDULE





SCALE
NTS

DRAWING NO
EX2.12

DATE
DEC.06.2023

OBJECT SCHEDULE

OBJECT	CODE	DESCRIPTION
	07A-11	DRESSAGE BOOTS
	07A-12	JUMPING BOOTS
	07A-13	DRESSAGE PAD
	07A-14	JUMPING PAD

OBJECT	CODE	DESCRIPTION
	07A-15	HORSE LEG WRAPS
	07A-16	HORSE LUNGE LINE
	07A-17	BELL BOOTS
	07A-18	BRUSH
	07A-19	MANE AND TAIL BRUSH



PROJECT
HORSECENTRISM
THESIS CAPSTONE
EXHIBIT

DRAWN BY
FLAVIA PEDROSA TONIETTO

SITE
**PARK AVENUE ARMORY
NEW YORK**



KEY PLAN

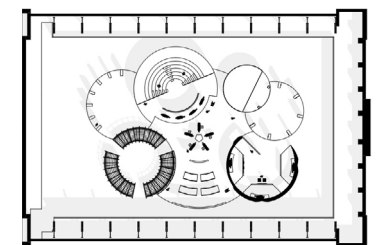

NOTES
DRAWINGS FOR
DESIGN INTENT
ONLY





DRAWING
OBJECT SCHEDULE
CONT'D





SCALE
NTS

DRAWING NO
EX2.13

DATE
DEC.06.2023

OBJECT SCHEDULE

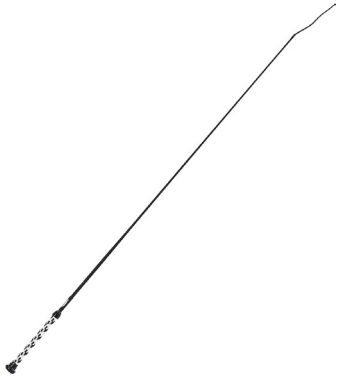
OBJECT	CODE	DESCRIPTION
	07A-20	METAL CURRY COMB
	07A-21	RUBBER CURRY COMB
	07A-22	HOOF PICK
	07A-23	SPONGE
	07A-24	HORSE SHOES

OBJECT	CODE	DESCRIPTION
	07A-25	HELMET
	07A-26	VEST
	07A-27	DRESSAGE WIPP
	07A-28	JUMP WIPP



PROJECT
HORSECENTRISM
THESIS CAPSTONE
EXHIBIT

DRAWN BY
FLAVIA PEDROSA TONIETTO

SITE
**PARK AVENUE ARMORY
NEW YORK**



KEY PLAN

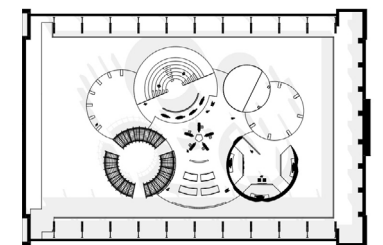

NOTES
DRAWINGS FOR
DESIGN INTENT
ONLY



DRAWING
**OBJECT SCHEDULE
CONT'D**

SCALE
NTS

DRAWING NO
EX2.14

DATE
DEC.06.2023

OBJECT SCHEDULE

OBJECT	CODE	DESCRIPTION
	07A-29	DRESSAGE REINS
	07A-30	REINS



PROJECT
HORSECENTRISM
THESIS CAPSTONE
EXHIBIT

DRAWN BY
FLAVIA PEDROSA TONIETTO

SITE
**PARK AVENUE ARMORY
NEW YORK**

CLIENTS



KEY PLAN

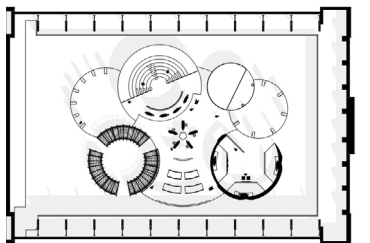

NOTES
DRAWINGS FOR
DESIGN INTENT
ONLY

DRAWING
**OBJECT SCHEDULE
CONT'D**

SCALE
NTS

DRAWING NO
EX2.15

DATE
DEC.06.2023

PLANS, ELEVATIONS, & SECTIONS

SYMBOLS LIST

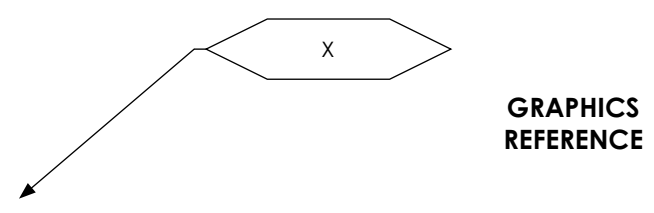
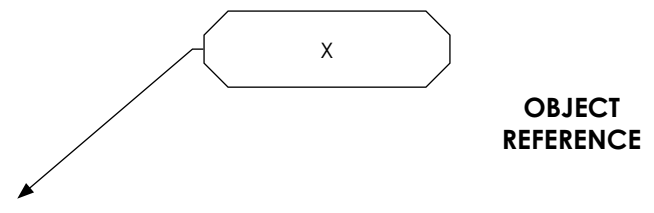
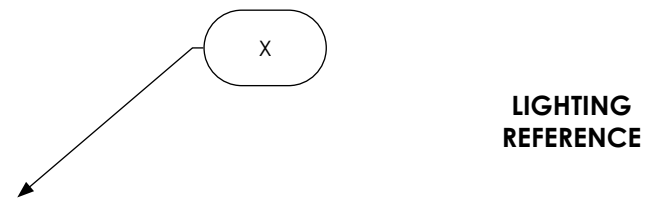
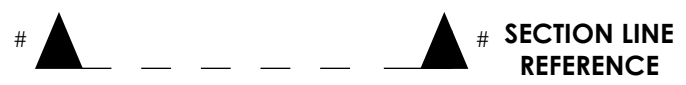
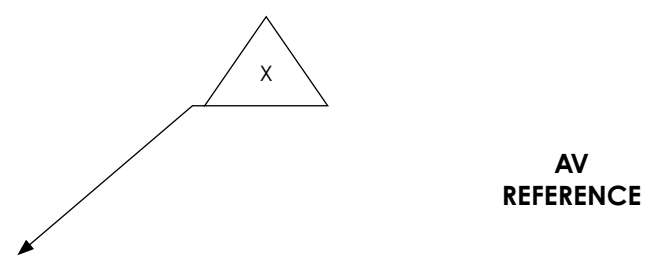
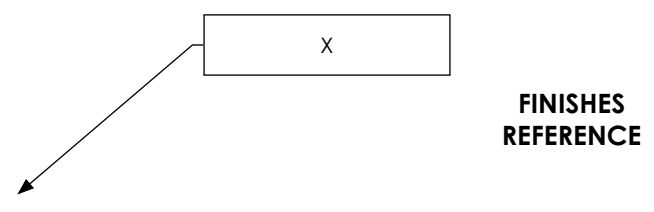

PROJECT
HORSECENTRISM
THESIS CAPSTONE EXHIBIT

DRAWN BY
FLAVIA PEDROSA TONIETTO

SITE
**PARK AVENUE ARMORY
NEW YORK**



KEY PLAN

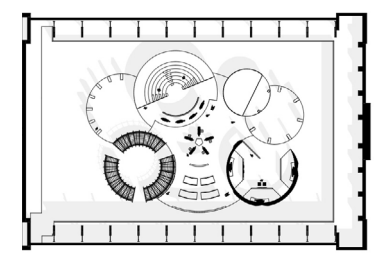

NOTES
DRAWINGS FOR DESIGN INTENT ONLY

DRAWING SYMBOLS LIST

SCALE
NTS

DRAWING NO
EX3.01

DATE
DEC.06.2023



PROJECT
HORSECENTRISM
THESIS CAPSTONE
EXHIBIT

DRAWN BY
FLAVIA PEDROSA TONIETTO

SITE
**PARK AVENUE ARMORY
NEW YORK**

CLIENTS



KEY PLAN

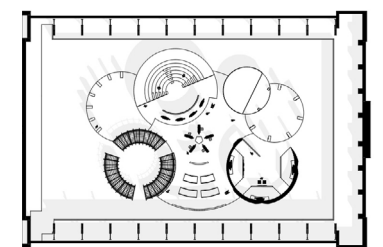

NOTES
DRAWINGS FOR
DESIGN INTENT
ONLY

DRAWING
LOCATION PLAN

SCALE
1"=500'

DATE
DEC.06.2023

DRAWING NO
EX3.02

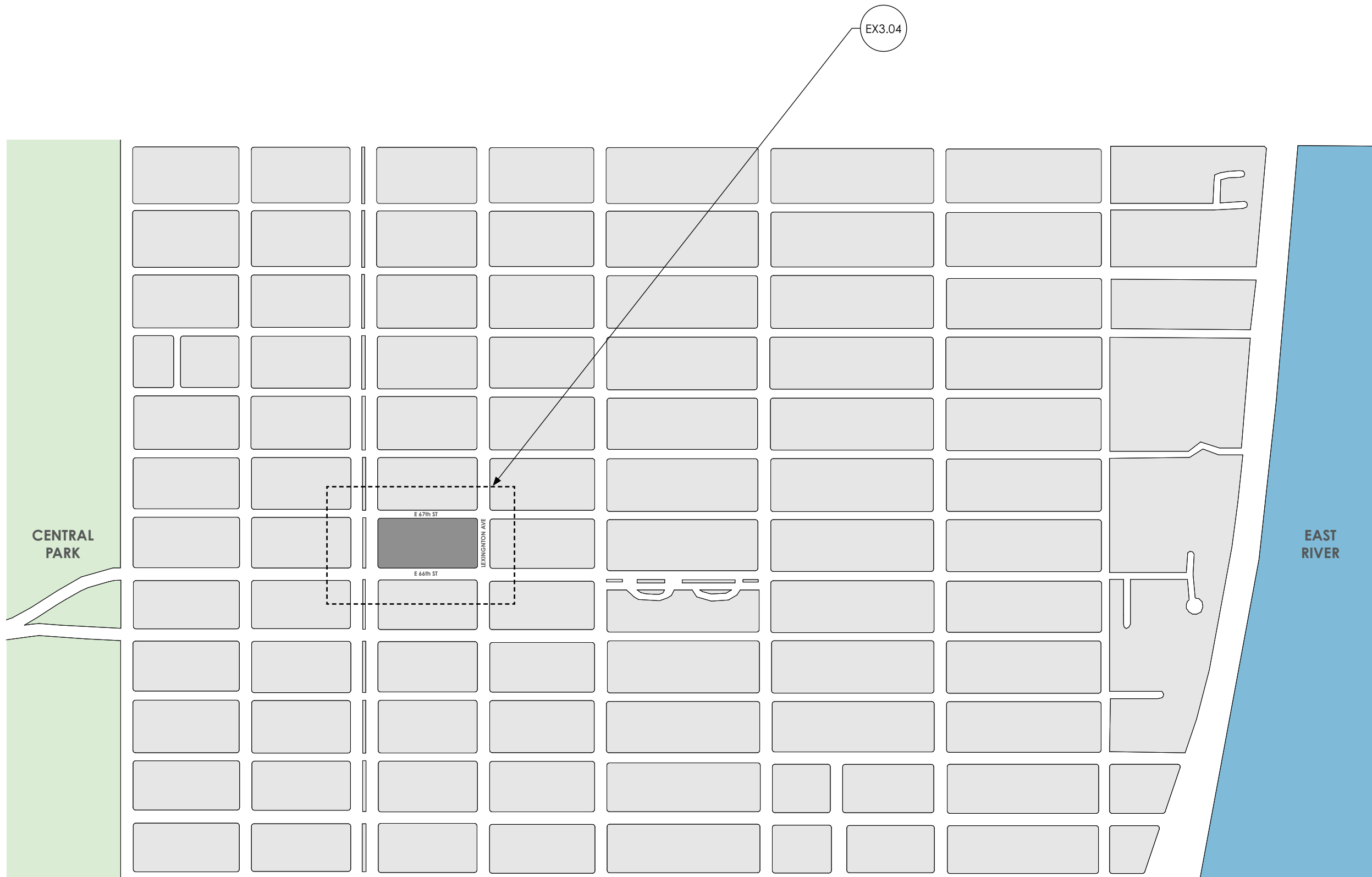

1 **LOCATION PLAN**
scale: 1"=500'





PROJECT
HORSECENTRISM
THESIS CAPSTONE
EXHIBIT

DRAWN BY
FLAVIA PEDROSA TONIETTO

SITE
**PARK AVENUE ARMORY
NEW YORK**



KEY PLAN

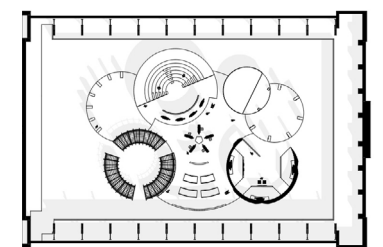

NOTES
DRAWINGS FOR
DESIGN INTENT
ONLY

DRAWING
GRAPHIC LOCATION PLAN

SCALE
1"=100'

DATE
DEC.06.2023

DRAWING NO
EX3.03

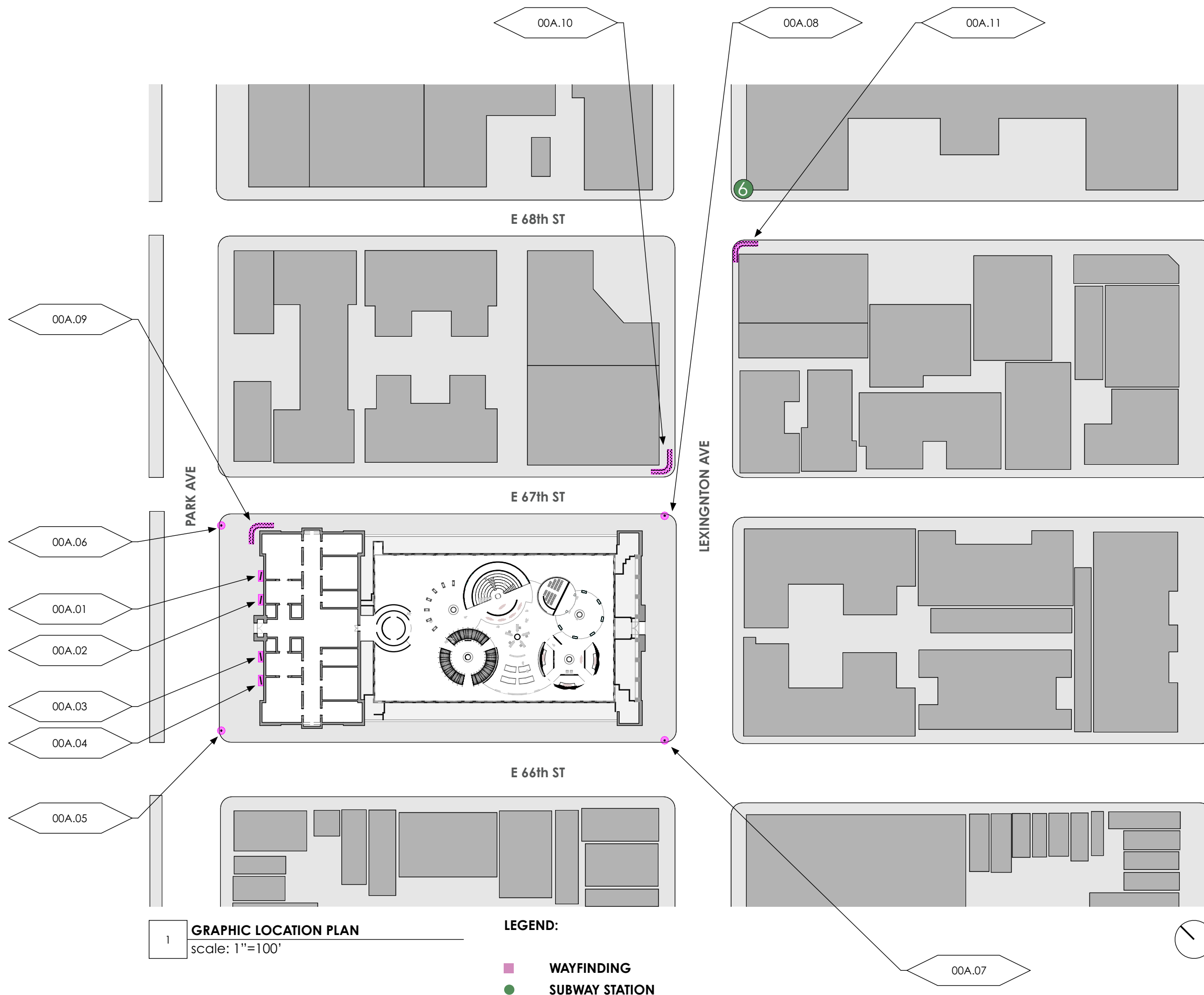



PROJECT
HORSECENTRISM
THESIS CAPSTONE
EXHIBIT

DRAWN BY
FLAVIA PEDROSA TONIETTO

SITE
**PARK AVENUE ARMORY
NEW YORK**



KEY PLAN

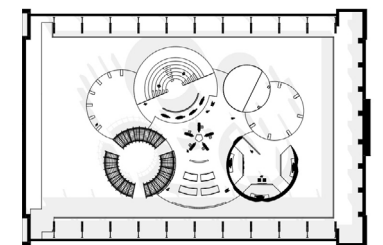

NOTES
DRAWINGS FOR
DESIGN INTENT
ONLY

DRAWING
SITE PLAN

SCALE
1"=40'

DATE
DEC.06.2023

DRAWING NO
EX3.04

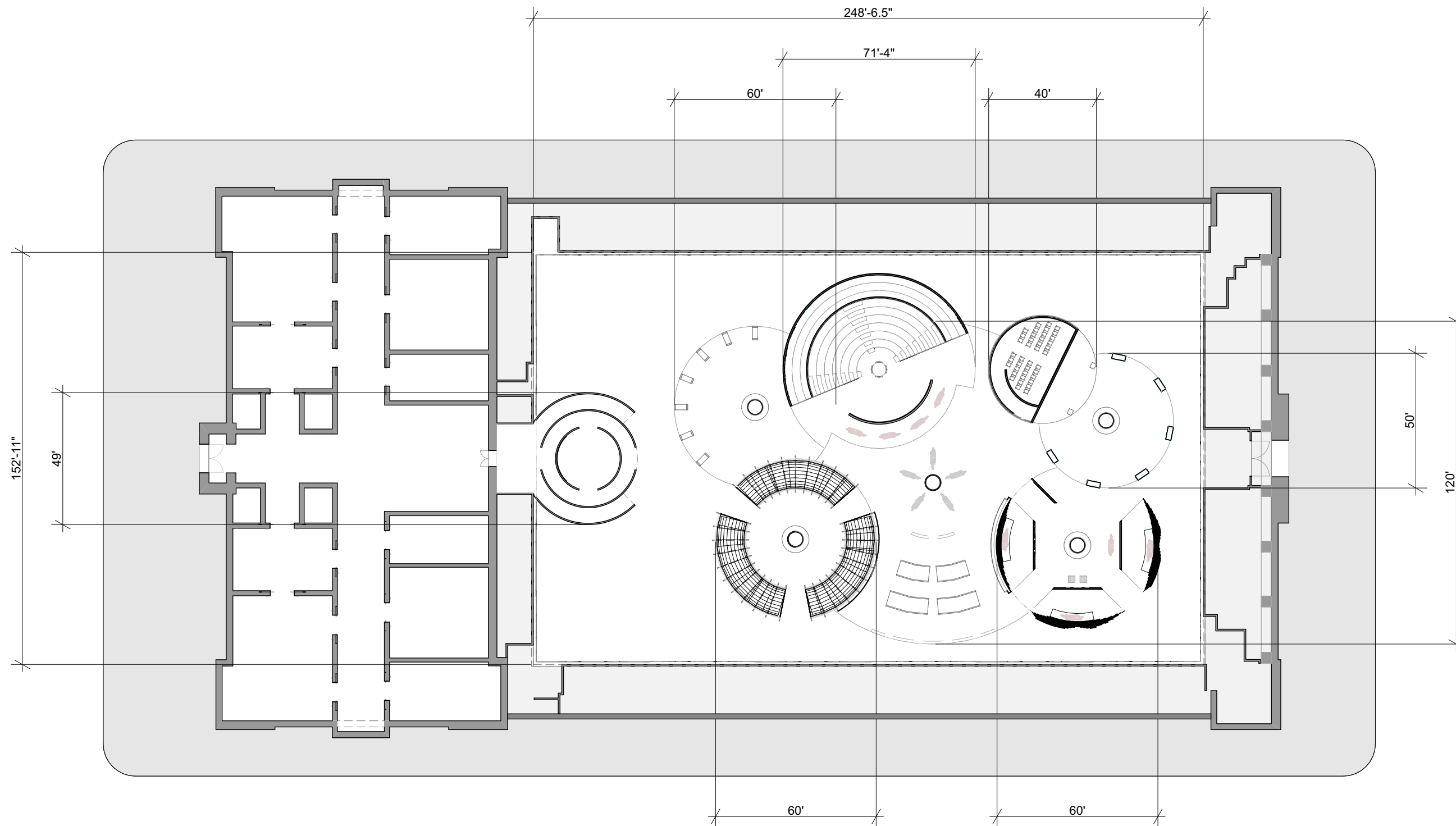

1 **SITE PLAN**
scale: 1"=40'





PROJECT
HORSECENTRISM
THESIS CAPSTONE
EXHIBIT

DRAWN BY
FLAVIA PEDROSA TONIETTO

SITE
**PARK AVENUE ARMORY
NEW YORK**



KEY PLAN

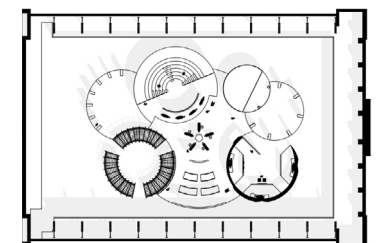

NOTES
DRAWINGS FOR
DESIGN INTENT
ONLY

DRAWING
CODED FLOOR PLAN

SCALE
1"=30'

DATE
DEC.06.2023

DRAWING NO
EX3.05

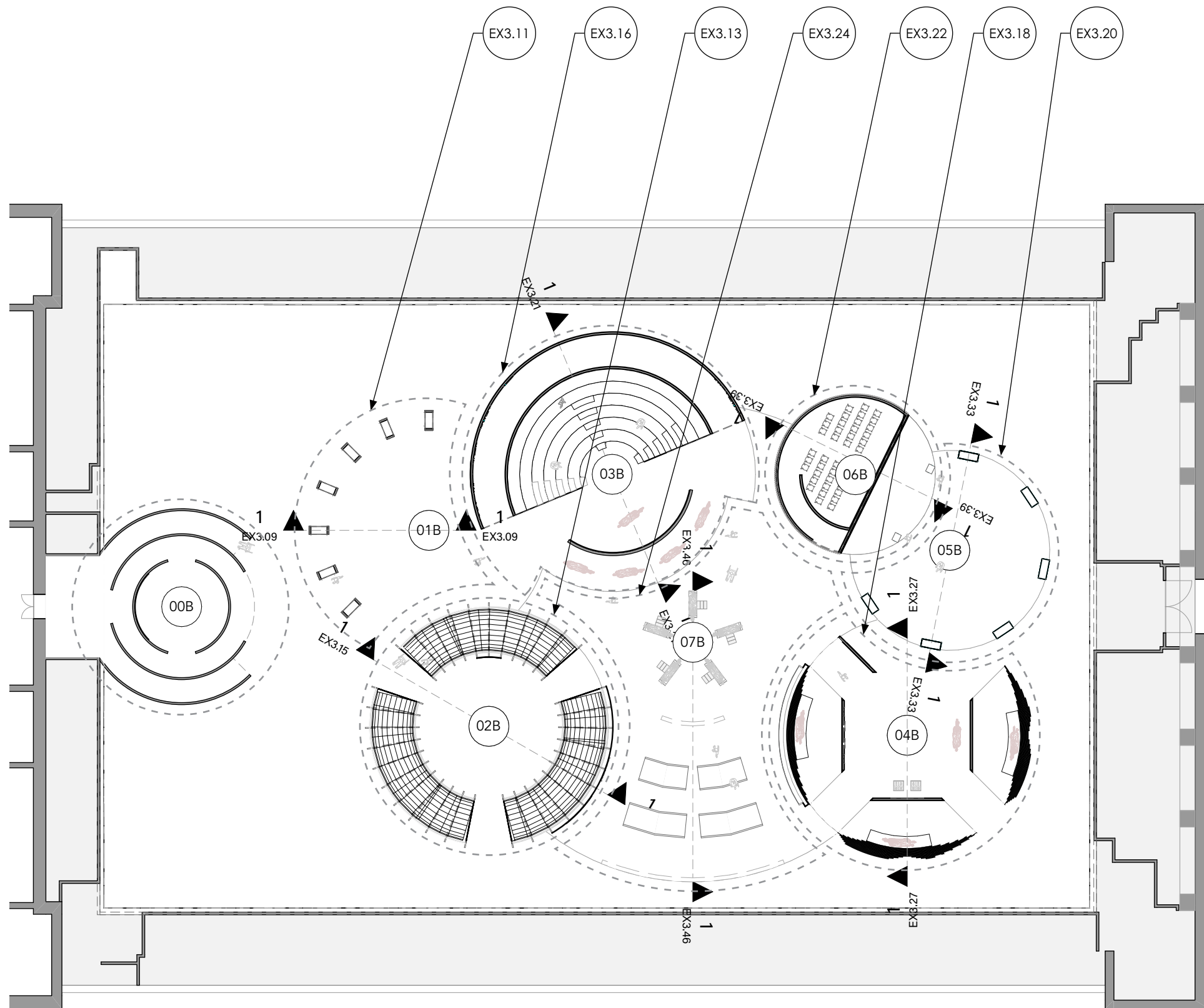

AREA LEGEND:

- 00B INTRODUCTION VIDEO
- 01B ARMIES & WARRIORS
- 02B WWI
- 03B HORSES & THE ARTS
- 04B THE EQUESTRIAN WORLD
- 05B A BILLION-DOLLAR INDUSTRY
- 06B THE EQUINE CARBON "HOOFPRINT"
- 07B EQUINE-ASSISTED THERAPY/POWER & LIFE

1 CODED FLOOR PLAN
scale: 1"=30'



PROJECT
HORSECENTRISM
THESIS CAPSTONE
EXHIBIT

DRAWN BY
FLAVIA PEDROSA TONIETTO

SITE
**PARK AVENUE ARMORY
NEW YORK**

CLIENTS



KEY PLAN

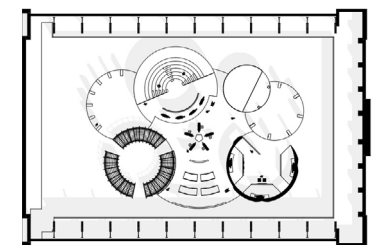

NOTES
DRAWINGS FOR
DESIGN INTENT
ONLY

DRAWING
GRAPHIC LOCATION PLAN

SCALE
1"=30'

DATE
DEC.06.2023

DRAWING NO
EX3.06

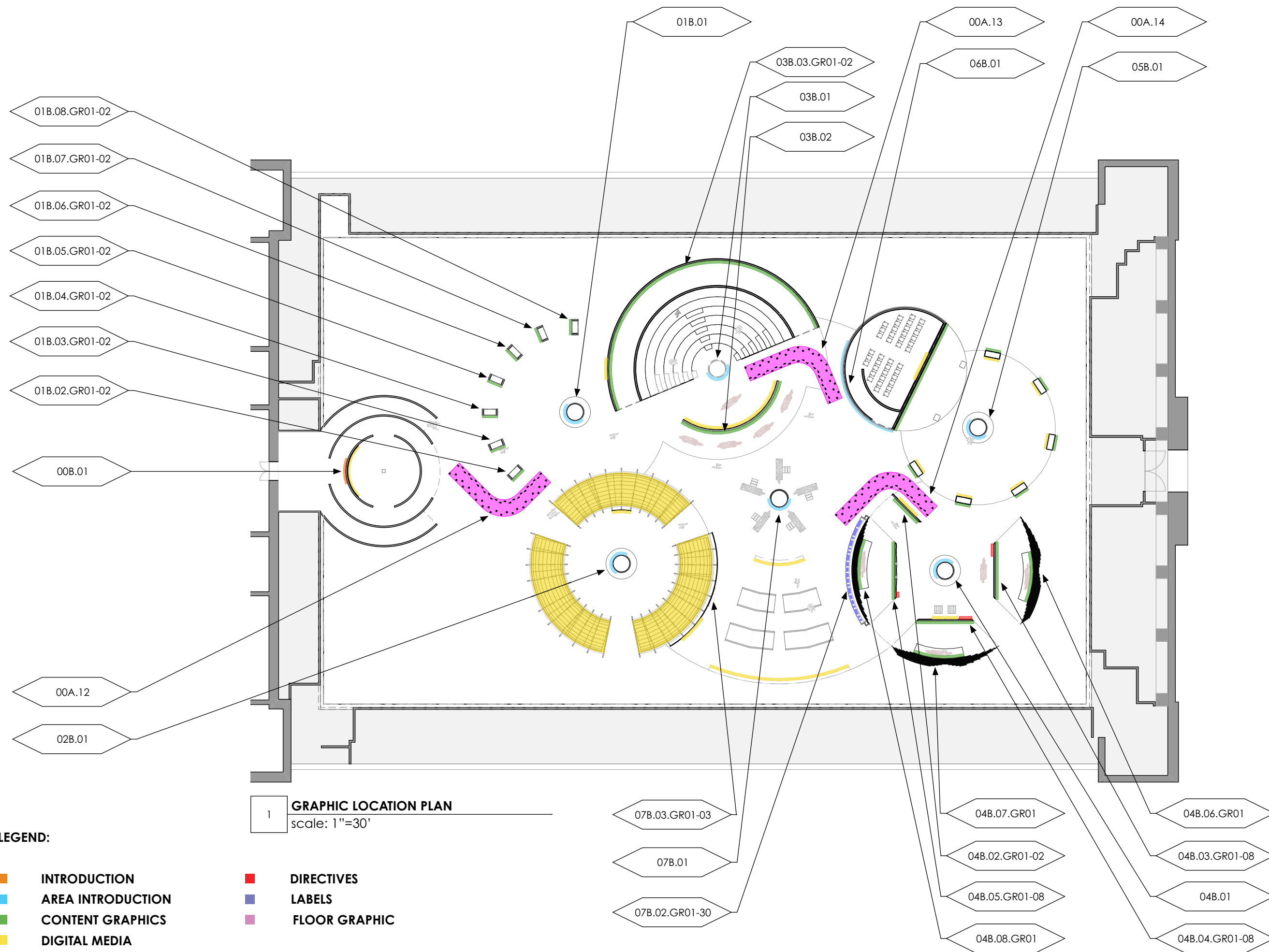



PROJECT
HORSECENTRISM
THESIS CAPSTONE
EXHIBIT

DRAWN BY
FLAVIA PEDROSA TONIETTO

SITE
**PARK AVENUE ARMORY
NEW YORK**

CLIENTS



KEY PLAN

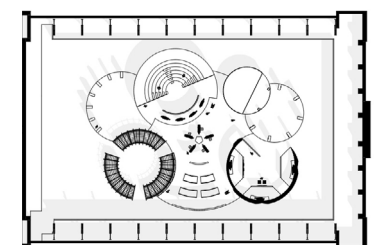

NOTES
DRAWINGS FOR
DESIGN INTENT
ONLY

DRAWING
FINISH FLOOR PLAN

SCALE
1"=30'

DATE
DEC.06.2023

DRAWING NO
ex3.07

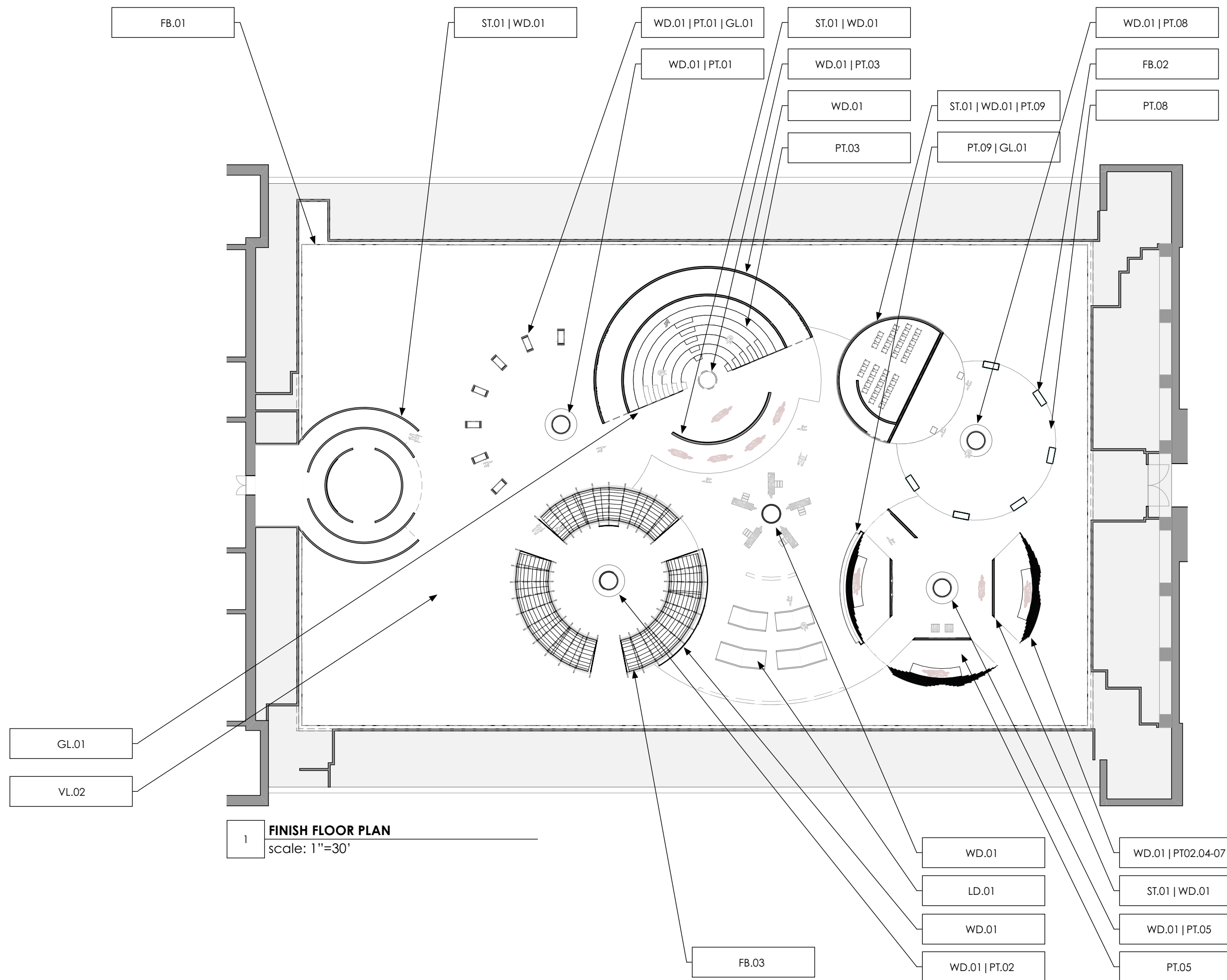



PROJECT
HORSECENTRISM
THESIS CAPSTONE
EXHIBIT

DRAWN BY
FLAVIA PEDROSA TONIETTO

SITE
**PARK AVENUE ARMORY
NEW YORK**

CLIENTS



KEY PLAN

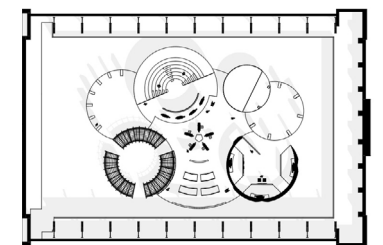

NOTES
DRAWINGS FOR
DESIGN INTENT
ONLY

DRAWING
AV PLAN

SCALE
1"=30'

DATE
DEC.06.2023

DRAWING NO
EX3.08

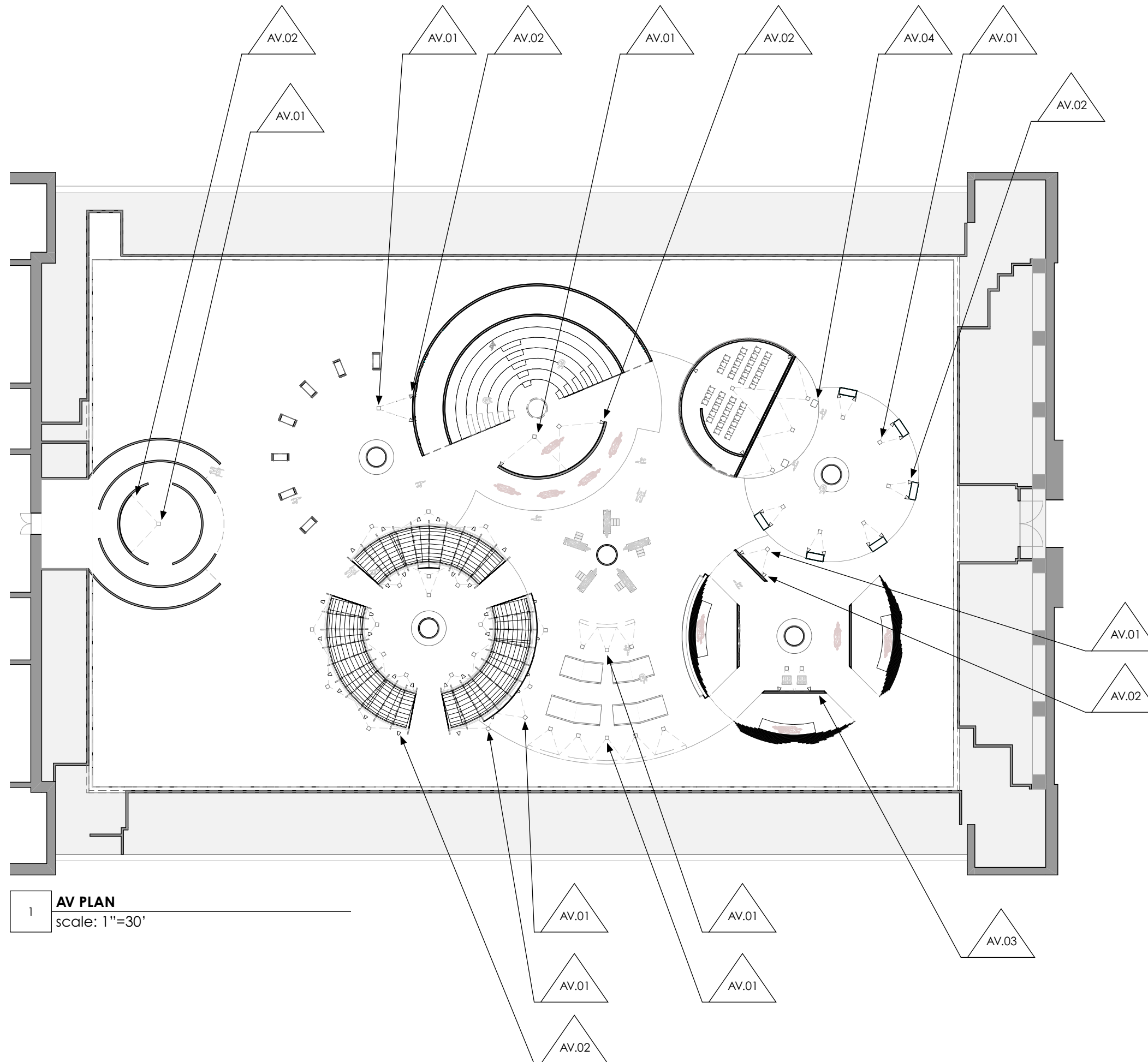

1 **AV PLAN**
scale: 1"=30'



PROJECT
HORSECENTRISM
THESIS CAPSTONE
EXHIBIT

DRAWN BY
FLAVIA PEDROSA TONIETTO

SITE
**PARK AVENUE ARMORY
NEW YORK**

CLIENTS



KEY PLAN

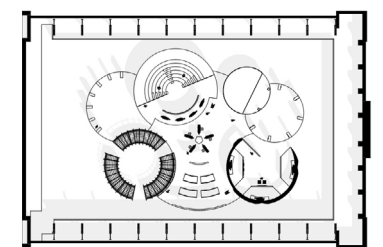

NOTES
DRAWINGS FOR
DESIGN INTENT
ONLY

DRAWING
RCP PLAN

SCALE
1"=30'

DATE
DEC.06.2023

DRAWING NO
EX3.09

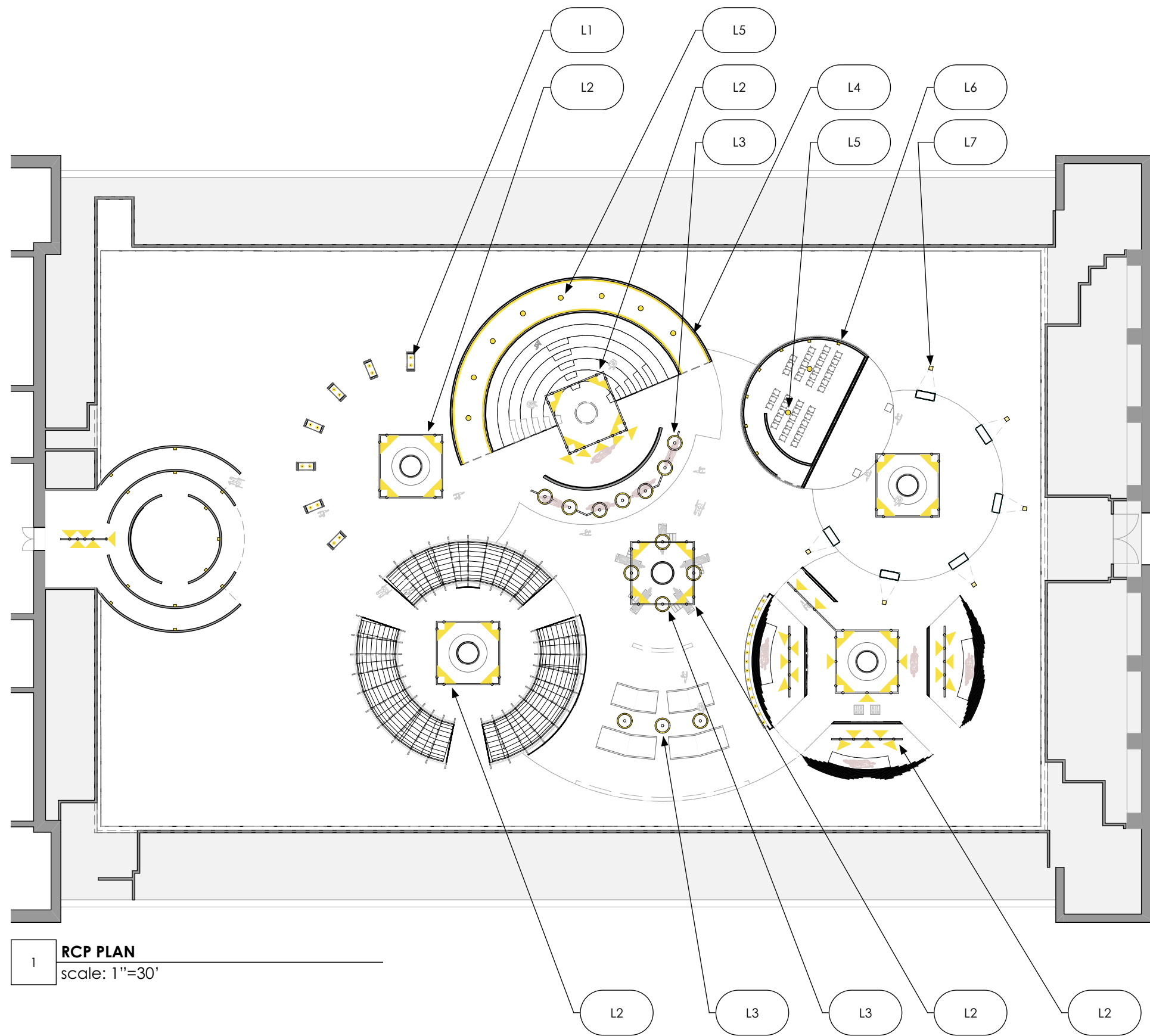



PROJECT
HORSECENTRISM
THESIS CAPSTONE
EXHIBIT

DRAWN BY
FLAVIA PEDROSA TONIETTO

SITE
**PARK AVENUE ARMORY
NEW YORK**



KEY PLAN

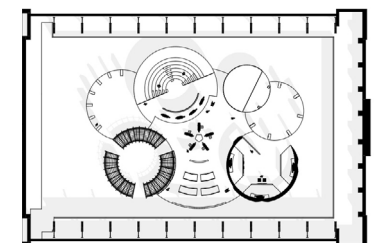

NOTES
DRAWINGS FOR
DESIGN INTENT
ONLY

DRAWING
**TRANSVERSAL & LONGITUDINAL
SECTIONS**

SCALE
1"=20'

DATE
DEC.06.2023

DRAWING NO
EX3.10

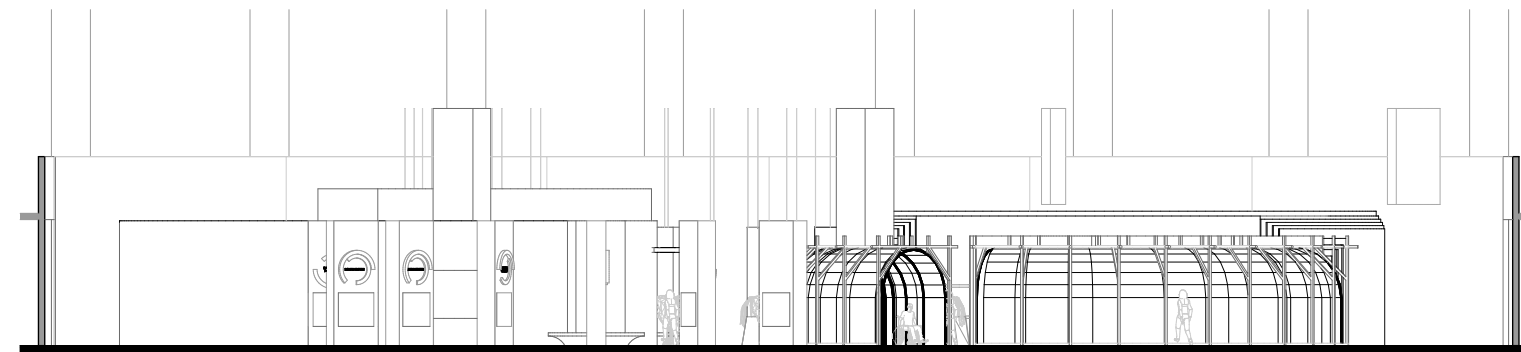

1 **TRANSVERSAL SECTION**
scale: 1"=20'

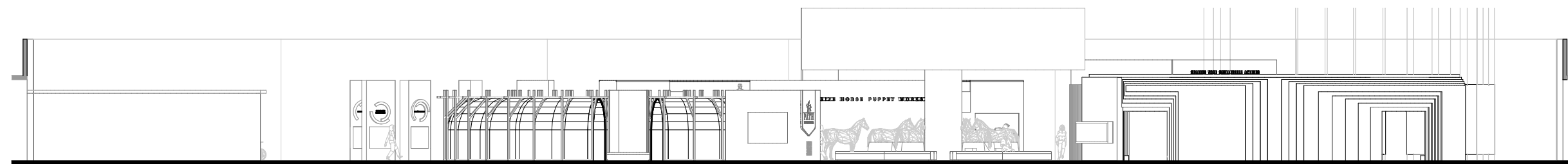

1 **LONGITUDINAL SECTION**
scale: 1"=20'



PROJECT
HORSECENTRISM
THESIS CAPSTONE
EXHIBIT

DRAWN BY
FLAVIA PEDROSA TONIETTO

SITE
**PARK AVENUE ARMORY
NEW YORK**



KEY PLAN

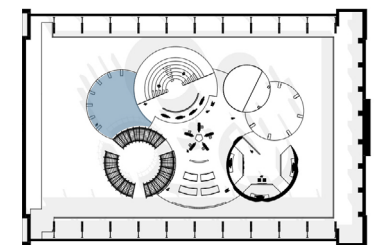

NOTES
DRAWINGS FOR
DESIGN INTENT
ONLY

DRAWING
01B DIMENSIONED PLAN

SCALE
1/8"=1'

DATE
DEC.06.2023

DRAWING NO
EX3.11

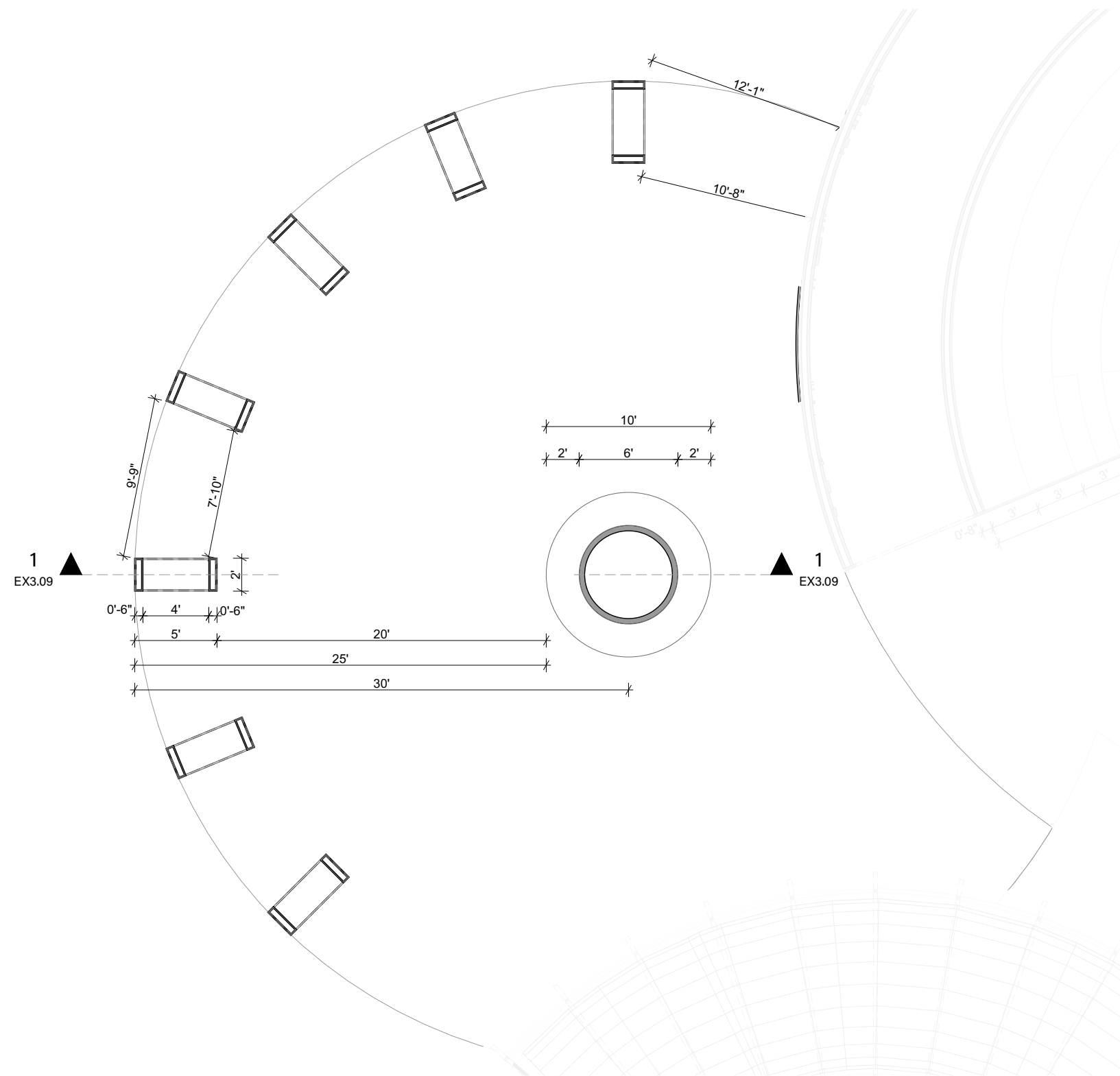

1 01B DIMENSIONED FLOOR PLAN
scale: 1/8"=1'



PROJECT
HORSECENTRISM
THESIS CAPSTONE
EXHIBIT

DRAWN BY
FLAVIA PEDROSA TONIETTO

SITE
**PARK AVENUE ARMORY
NEW YORK**



KEY PLAN

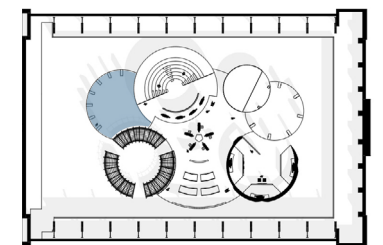

NOTES
DRAWINGS FOR
DESIGN INTENT
ONLY

DRAWING
01B SECTION

SCALE
1/4"=1'

DATE
DEC.06.2023

DRAWING NO
EX3.12

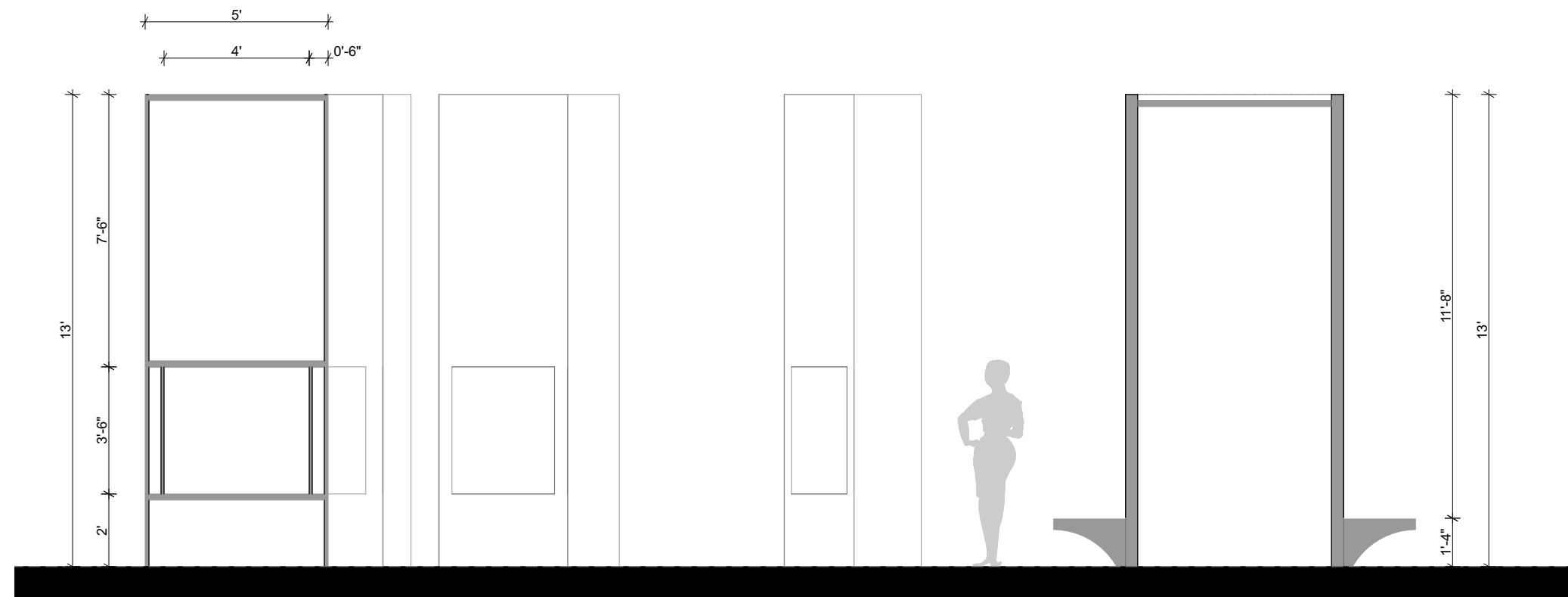

1 01B SECTION
scale: 1/4"=1'

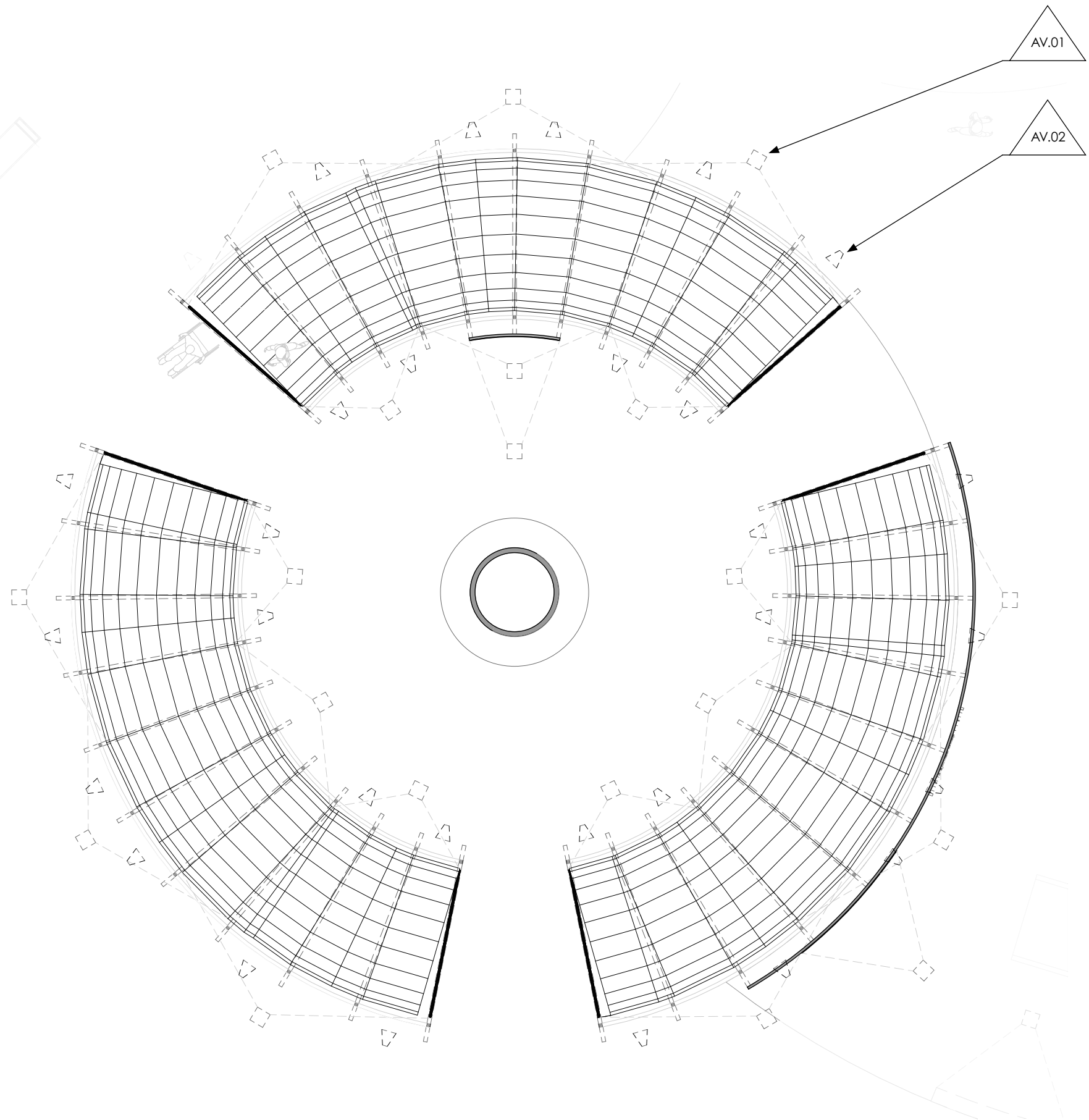

1 **02B AV PLAN**
scale: 1/8"=1'



PROJECT
HORSECENTRISM
THESIS CAPSTONE
EXHIBIT

DRAWN BY
FLAVIA PEDROSA TONIETTO

SITE
**PARK AVENUE ARMORY
NEW YORK**



KEY PLAN

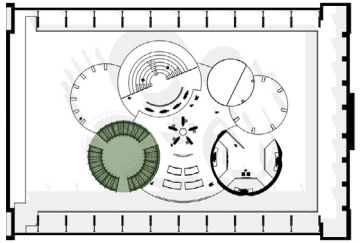

NOTES
DRAWINGS FOR
DESIGN INTENT
ONLY

DRAWING
02B AV PLAN

SCALE
1/8"=1'

DATE
DEC.06.2023

DRAWING NO
EX3.14



PROJECT
HORSECENTRISM
THESIS CAPSTONE
EXHIBIT

DRAWN BY
FLAVIA PEDROSA TONIETTO

SITE
**PARK AVENUE ARMORY
NEW YORK**



KEY PLAN

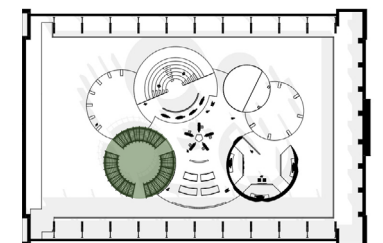

NOTES
DRAWINGS FOR
DESIGN INTENT
ONLY

DRAWING
02B SECTION

SCALE
3/16"=1'

DATE
DEC.06.2023

DRAWING NO
EX3.15

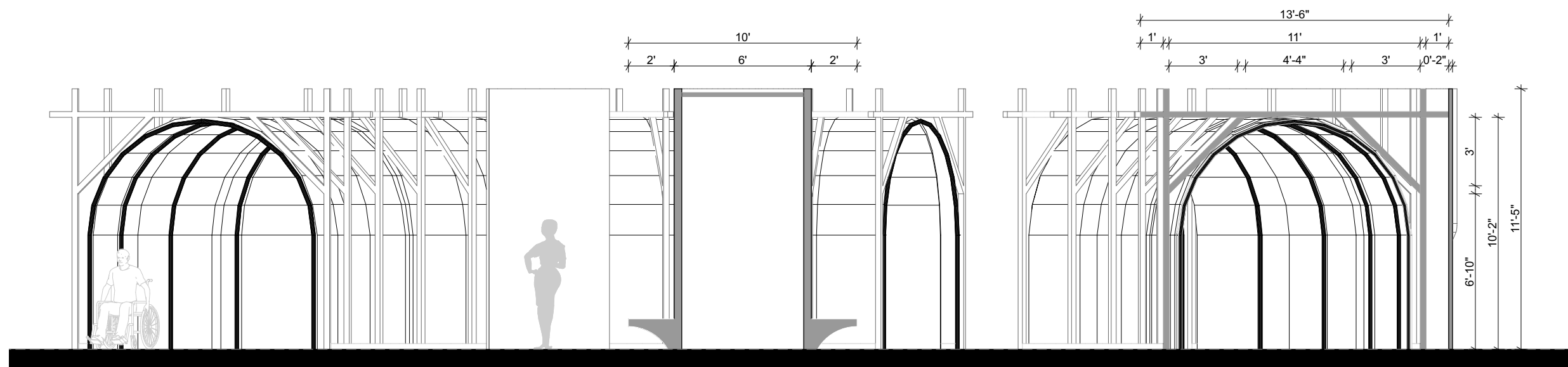

1 **02B SECTION**
scale: 3/16"=1'



PROJECT
HORSECENTRISM
THESIS CAPSTONE
EXHIBIT

DRAWN BY
FLAVIA PEDROSA TONIETTO

SITE
**PARK AVENUE ARMORY
NEW YORK**

CLIENTS



KEY PLAN

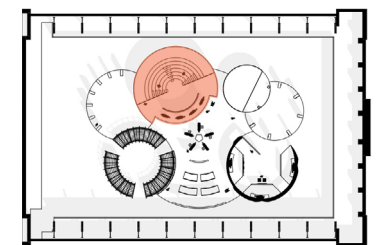

NOTES
DRAWINGS FOR
DESIGN INTENT
ONLY

DRAWING
03B DIMENSIONED PLAN

SCALE
1/8"=1'

DATE
DEC.06.2023

DRAWING NO
EX3.16

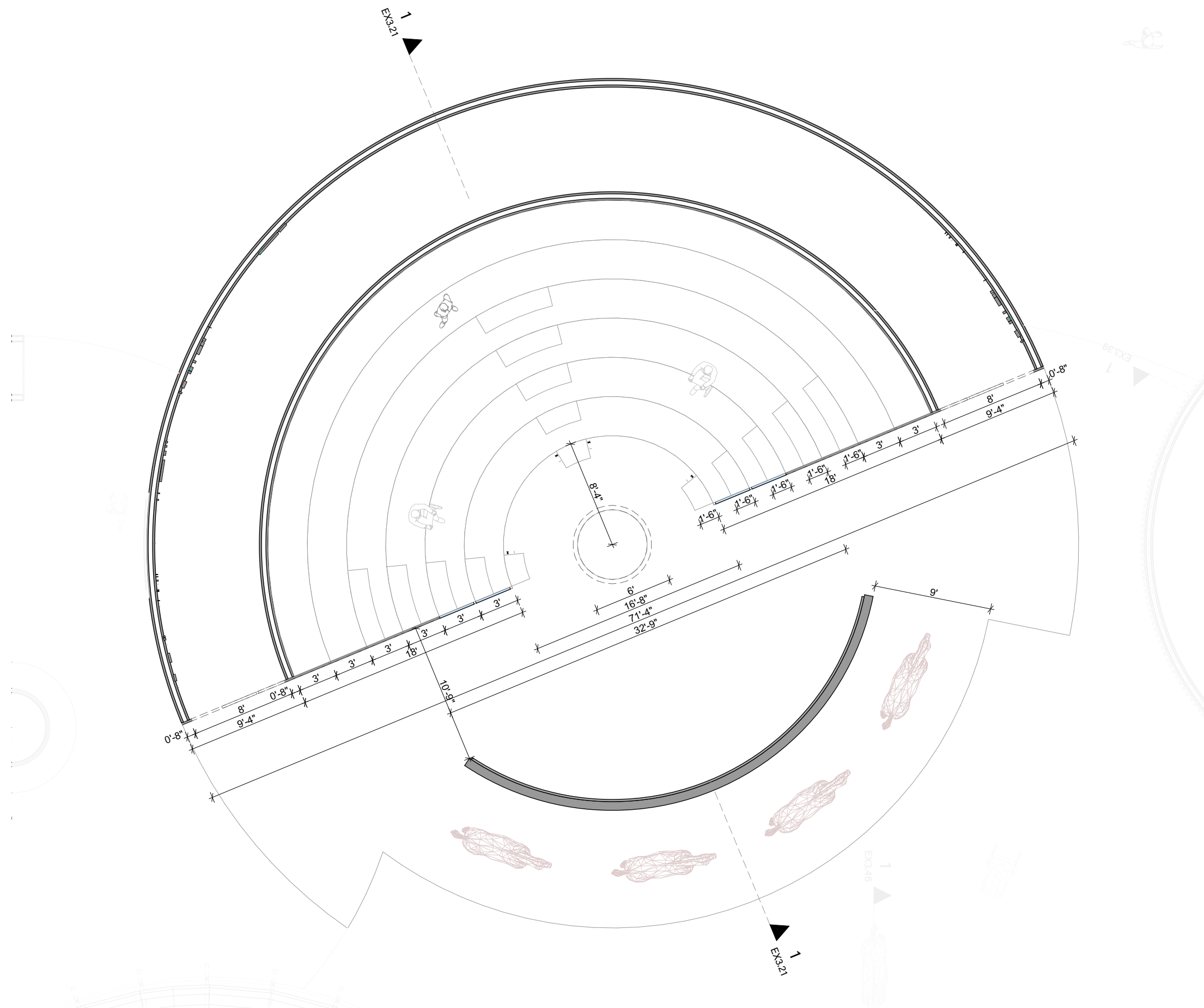

1 03B DIMENSIONED FLOOR PLAN
scale: 1/8"=1'



PROJECT
HORSECENTRISM
THESIS CAPSTONE
EXHIBIT

DRAWN BY
FLAVIA PEDROSA TONIETTO

SITE
**PARK AVENUE ARMORY
NEW YORK**



KEY PLAN

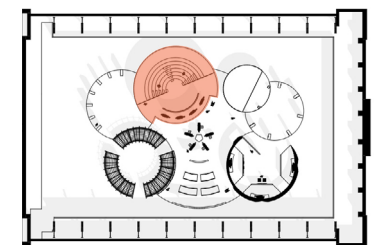

NOTES
DRAWINGS FOR
DESIGN INTENT
ONLY

DRAWING
03B SECTION

SCALE
3/16"=1'

DATE
DEC.06.2023

DRAWING NO
EX3.17

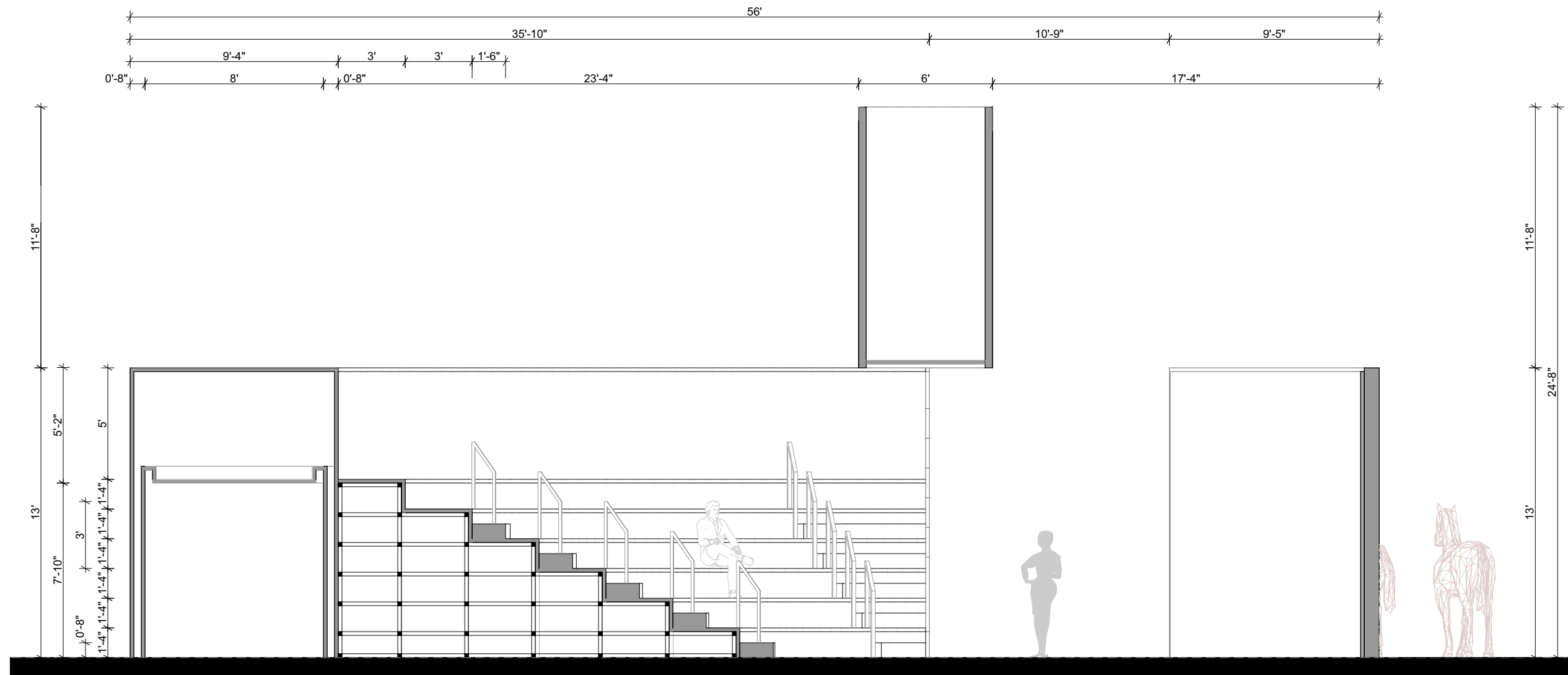

1 03B SECTION
scale: 3/16"=1'



PROJECT
HORSECENTRISM
THESIS CAPSTONE
EXHIBIT

DRAWN BY
FLAVIA PEDROSA TONIETTO

SITE
**PARK AVENUE ARMORY
NEW YORK**



KEY PLAN

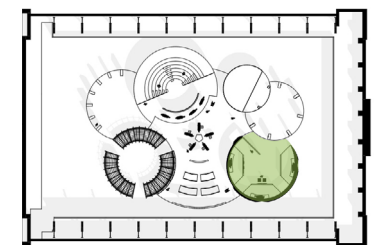

NOTES
DRAWINGS FOR
DESIGN INTENT
ONLY

DRAWING
04B DIMENSIONED PLAN

SCALE
1/8"=1'

DATE
DEC.06.2023

DRAWING NO
EX3.18

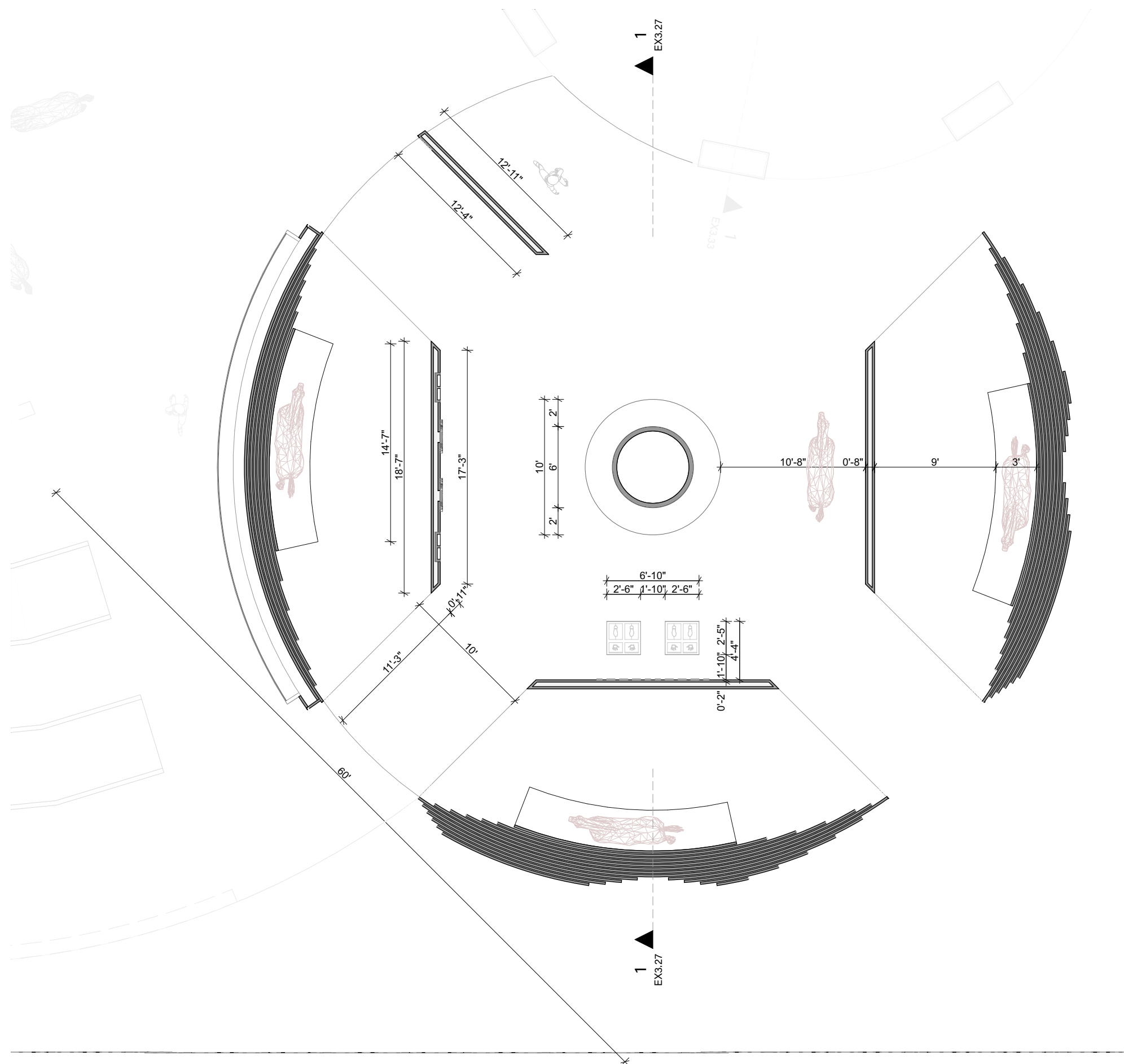

1 04B DIMENSIONED FLOOR PLAN
scale: 1/8"=1'



PROJECT
HORSECENTRISM
THESIS CAPSTONE
EXHIBIT

DRAWN BY
FLAVIA PEDROSA TONIETTO

SITE
**PARK AVENUE ARMORY
NEW YORK**



KEY PLAN

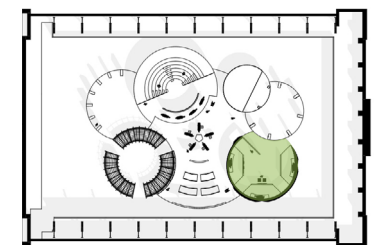

NOTES
DRAWINGS FOR
DESIGN INTENT
ONLY

DRAWING
04B SECTION

SCALE
3/16"=1'

DATE
DEC.06.2023

DRAWING NO
EX3.19

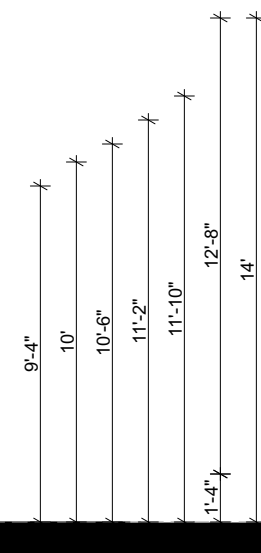
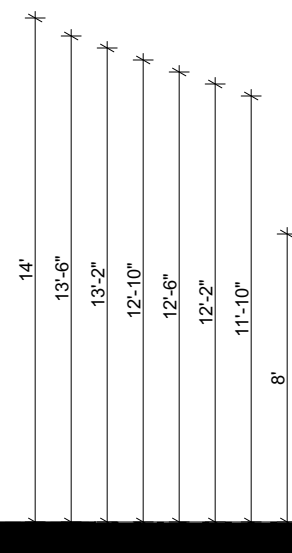
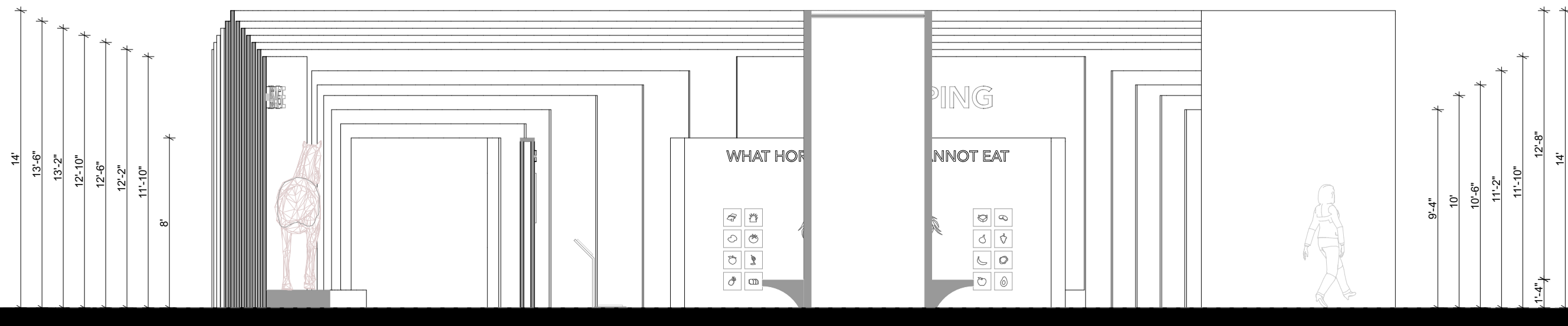
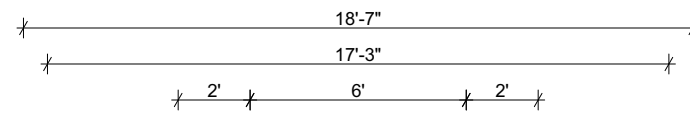

04B SECTION
scale: 3/16"=1'



PROJECT
HORSECENTRISM
THESIS CAPSTONE
EXHIBIT

DRAWN BY
FLAVIA PEDROSA TONIETTO

SITE
**PARK AVENUE ARMORY
NEW YORK**



KEY PLAN

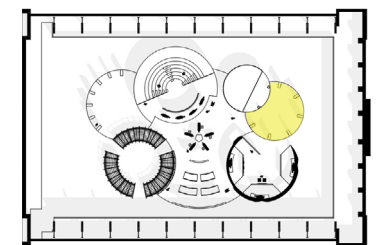

NOTES
DRAWINGS FOR
DESIGN INTENT
ONLY

DRAWING
05B DIMENSIONED PLAN

SCALE
1/8"=1'

DATE
DEC.06.2023

DRAWING NO
EX3.20

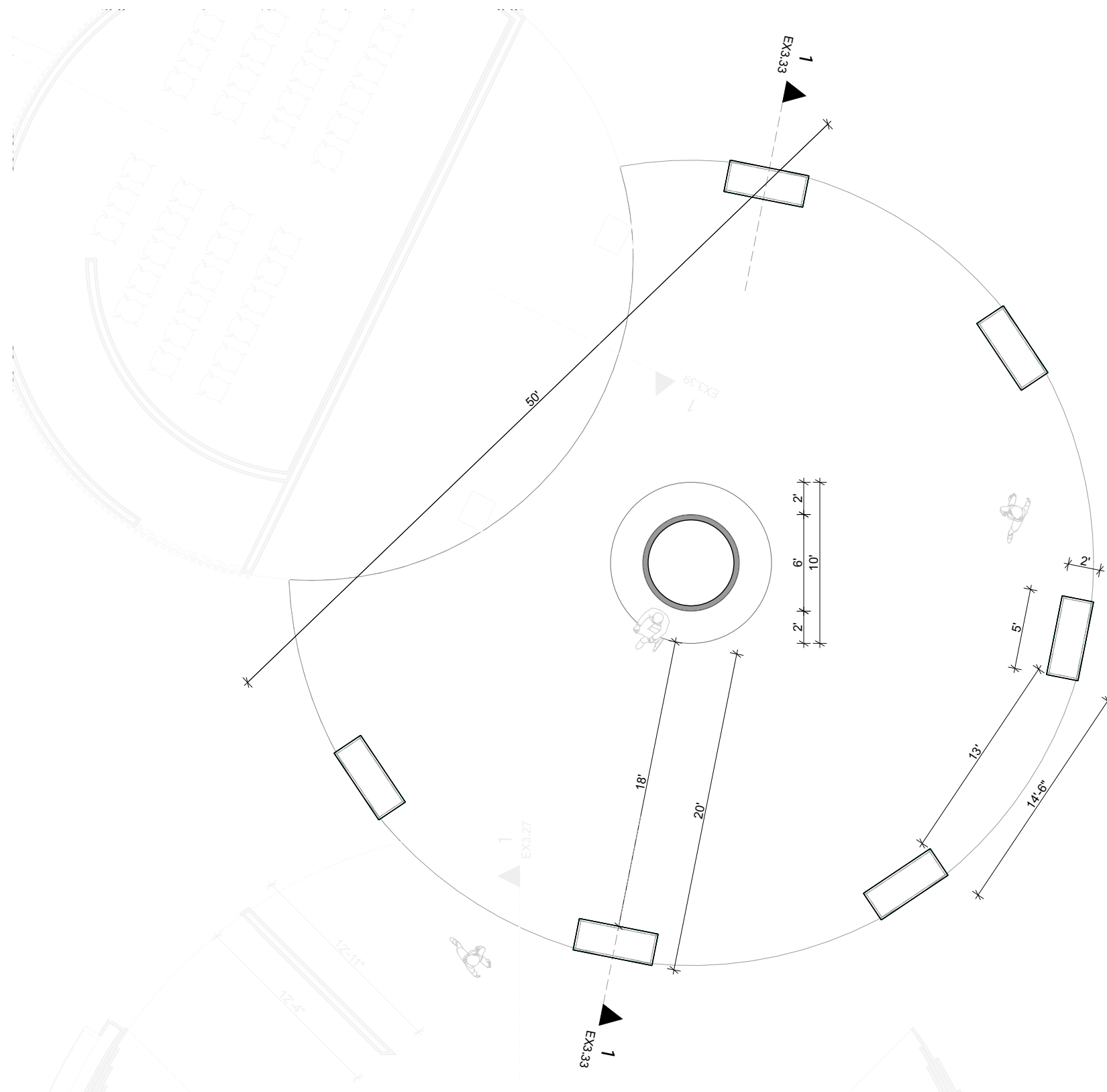

1 **05B DIMENSIONED FLOOR PLAN**
scale: 1/8"=1'



PROJECT
HORSECENTRISM
THESIS CAPSTONE
EXHIBIT

DRAWN BY
FLAVIA PEDROSA TONIETTO

SITE
**PARK AVENUE ARMORY
NEW YORK**



KEY PLAN

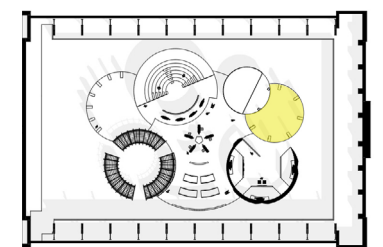

NOTES
DRAWINGS FOR
DESIGN INTENT
ONLY

DRAWING
05B SECTION

SCALE
3/16"=1'

DATE
DEC.06.2023

DRAWING NO
EX3.21

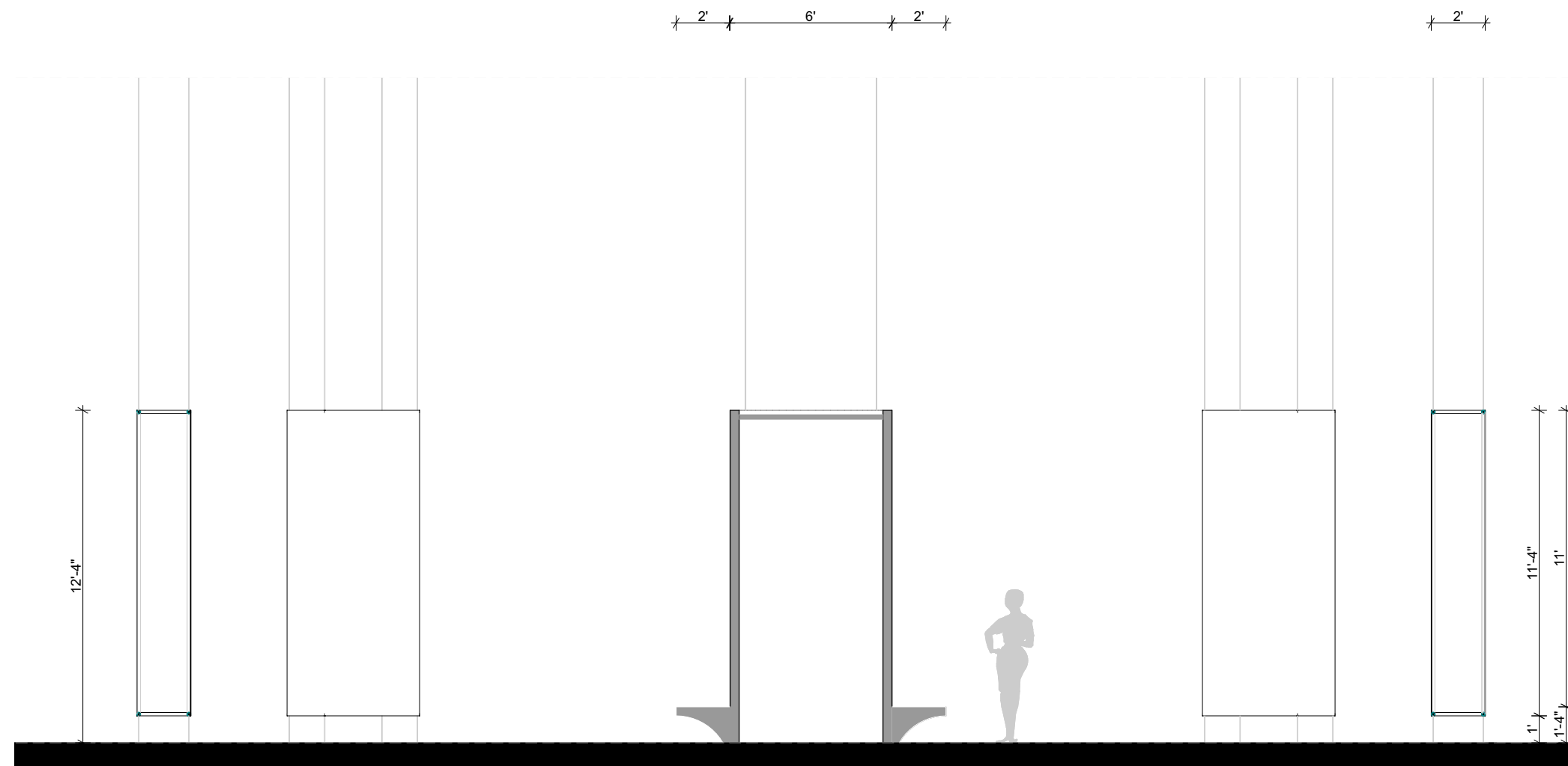

05B SECTION
scale: 3/16"=1'



PROJECT
HORSECENTRISM
THESIS CAPSTONE
EXHIBIT

DRAWN BY
FLAVIA PEDROSA TONIETTO

SITE
**PARK AVENUE ARMORY
NEW YORK**



KEY PLAN

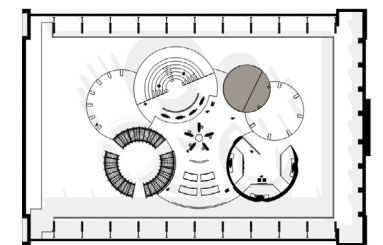

NOTES
DRAWINGS FOR
DESIGN INTENT
ONLY

DRAWING
06B DIMENSIONED PLAN

SCALE
1/8"=1'

DATE
DEC.06.2023

DRAWING NO
EX3.22

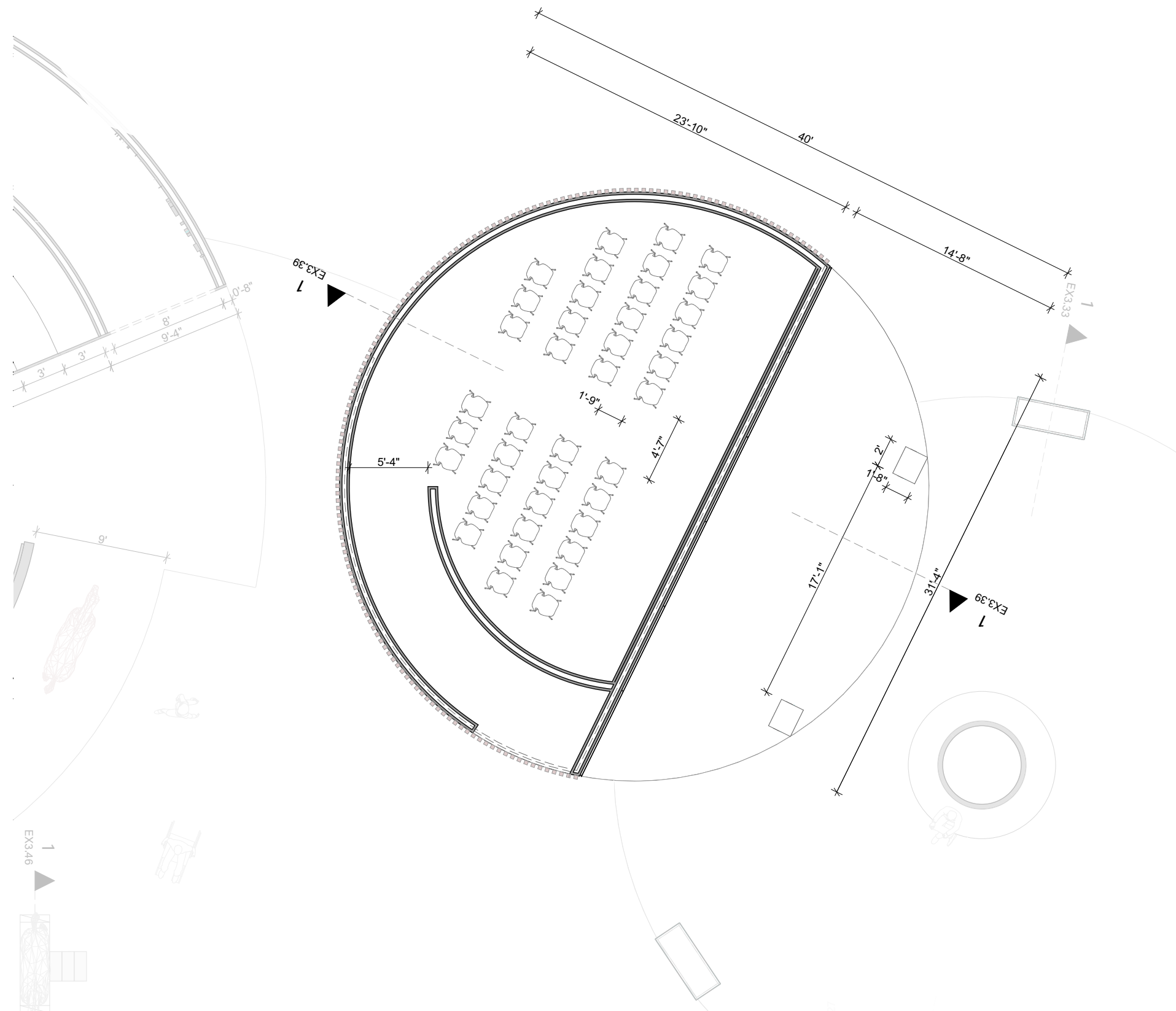

1 **06B DIMENSIONED FLOOR PLAN**
scale: 1/8"=1'



PROJECT
HORSECENTRISM
THESIS CAPSTONE
EXHIBIT

DRAWN BY
FLAVIA PEDROSA TONIETTO

SITE
**PARK AVENUE ARMORY
NEW YORK**



KEY PLAN

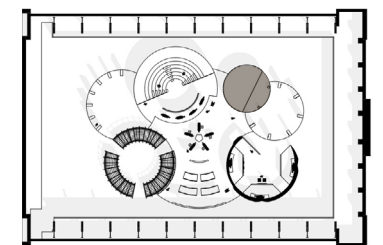

NOTES
DRAWINGS FOR
DESIGN INTENT
ONLY

DRAWING
06B SECTION

SCALE
3/16"=1'

DATE
DEC.06.2023

DRAWING NO
EX3.23

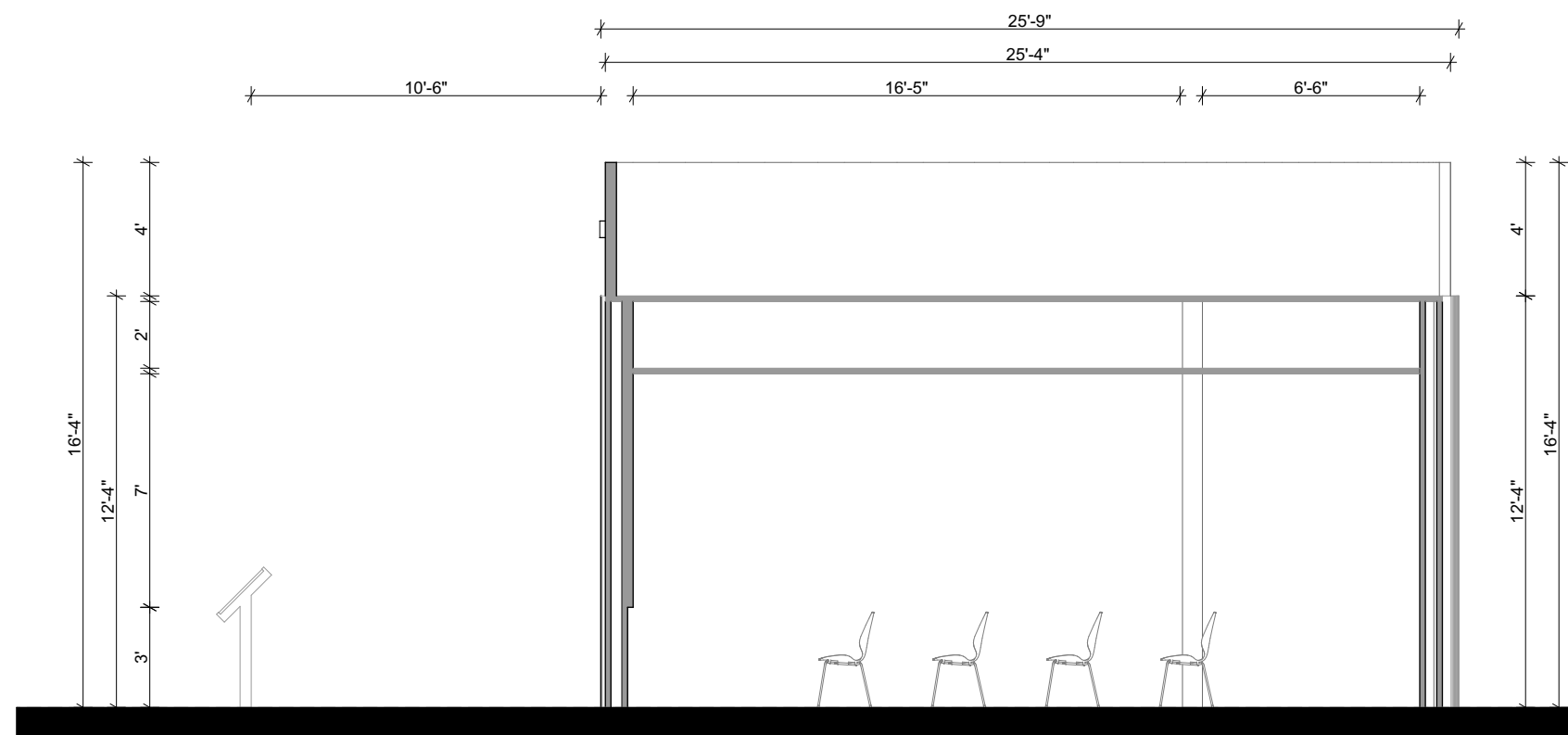

06B SECTION
scale: 3/16"=1'



PROJECT
HORSECENTRISM
THESIS CAPSTONE
EXHIBIT

DRAWN BY
FLAVIA PEDROSA TONIETTO

SITE
**PARK AVENUE ARMORY
NEW YORK**



KEY PLAN

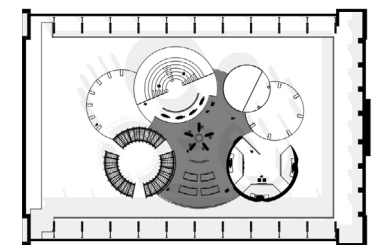

NOTES
DRAWINGS FOR
DESIGN INTENT
ONLY

DRAWING
07B DIMENSIONED PLAN

SCALE
3/32"=1'

DATE
DEC.06.2023

DRAWING NO
EX3.24

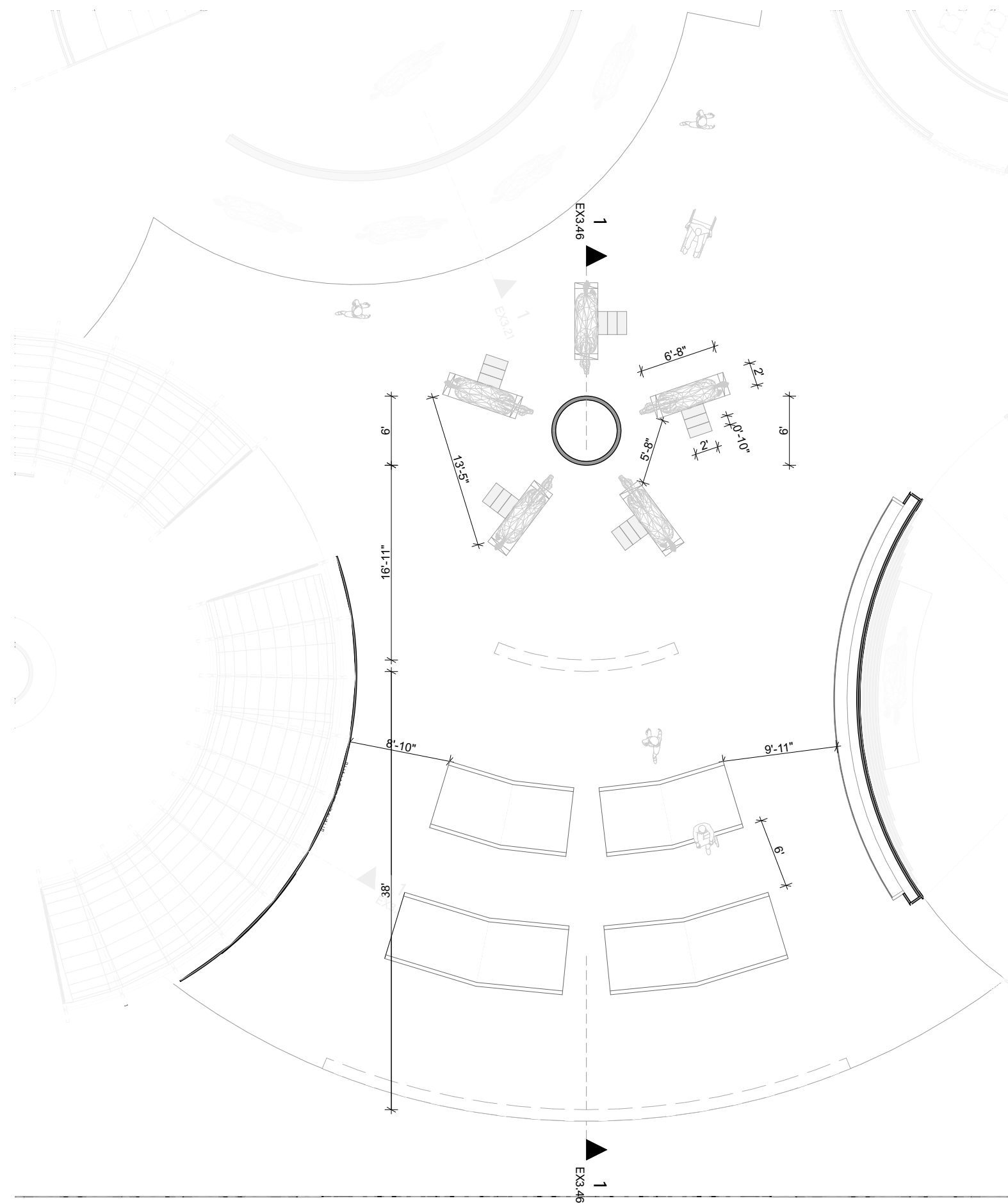

1 07B DIMENSIONED FLOOR PLAN
scale: 3/32"=1'



PROJECT
HORSECENTRISM
THESIS CAPSTONE
EXHIBIT

DRAWN BY
FLAVIA PEDROSA TONIETTO

SITE
**PARK AVENUE ARMORY
NEW YORK**



KEY PLAN

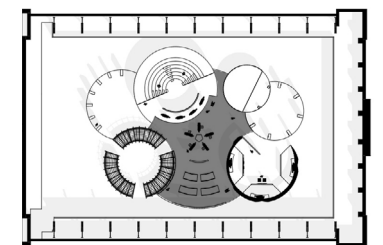

NOTES
DRAWINGS FOR
DESIGN INTENT
ONLY

DRAWING
07B OBJECT PLAN

SCALE
1/8"=1'

DATE
DEC.06.2023

DRAWING NO
EX3.25

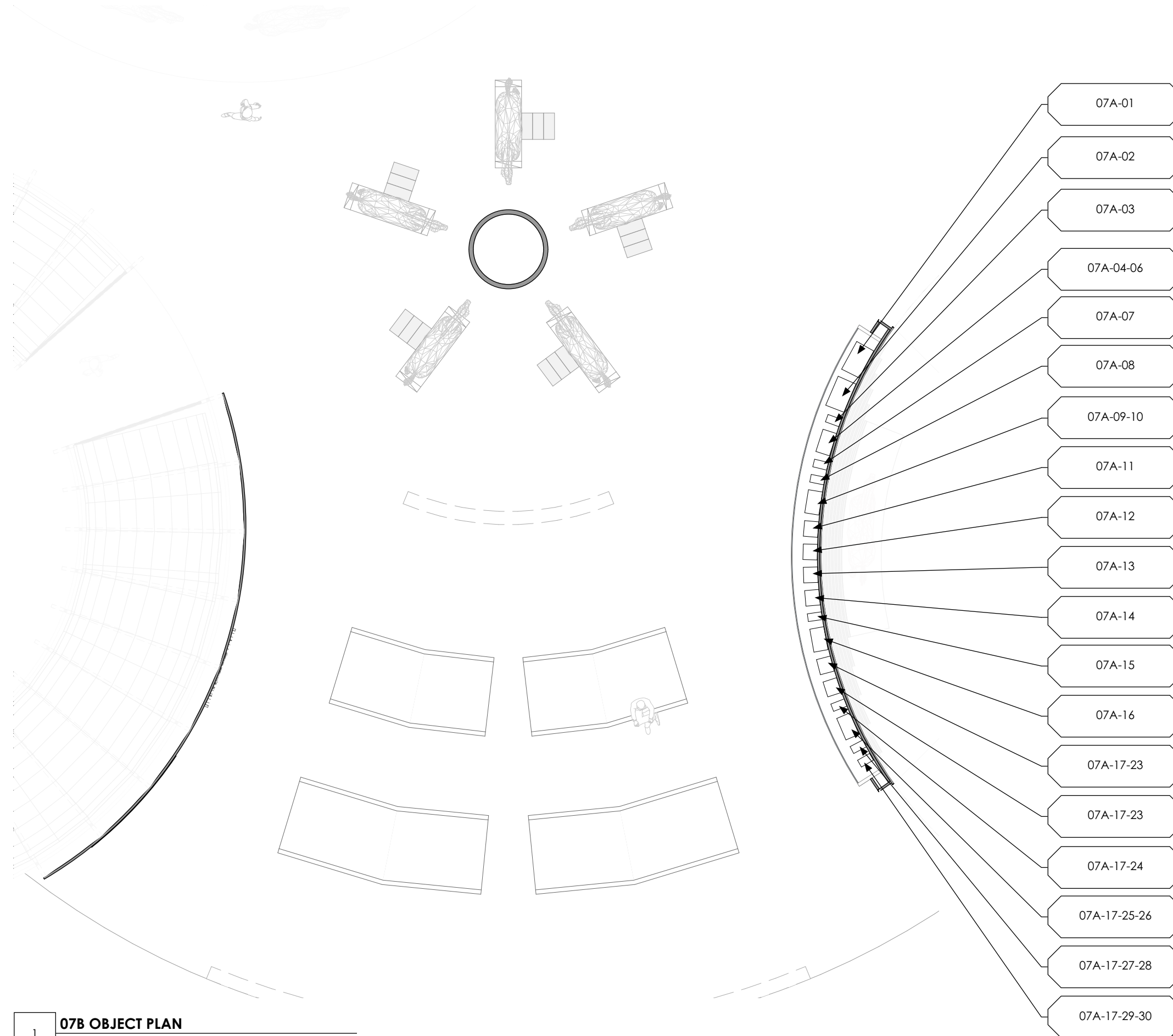

1 07B OBJECT PLAN
scale: 1/8"=1'



PROJECT
HORSECENTRISM
THESIS CAPSTONE
EXHIBIT

DRAWN BY
FLAVIA PEDROSA TONIETTO

SITE
**PARK AVENUE ARMORY
NEW YORK**



KEY PLAN

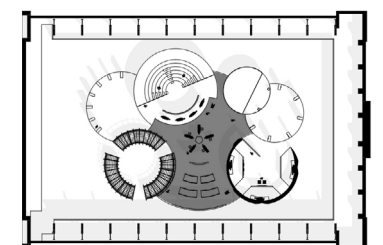

NOTES
DRAWINGS FOR
DESIGN INTENT
ONLY

DRAWING
07B SECTION

SCALE
1/8"=1'

DATE
DEC.06.2023

DRAWING NO
EX3.26

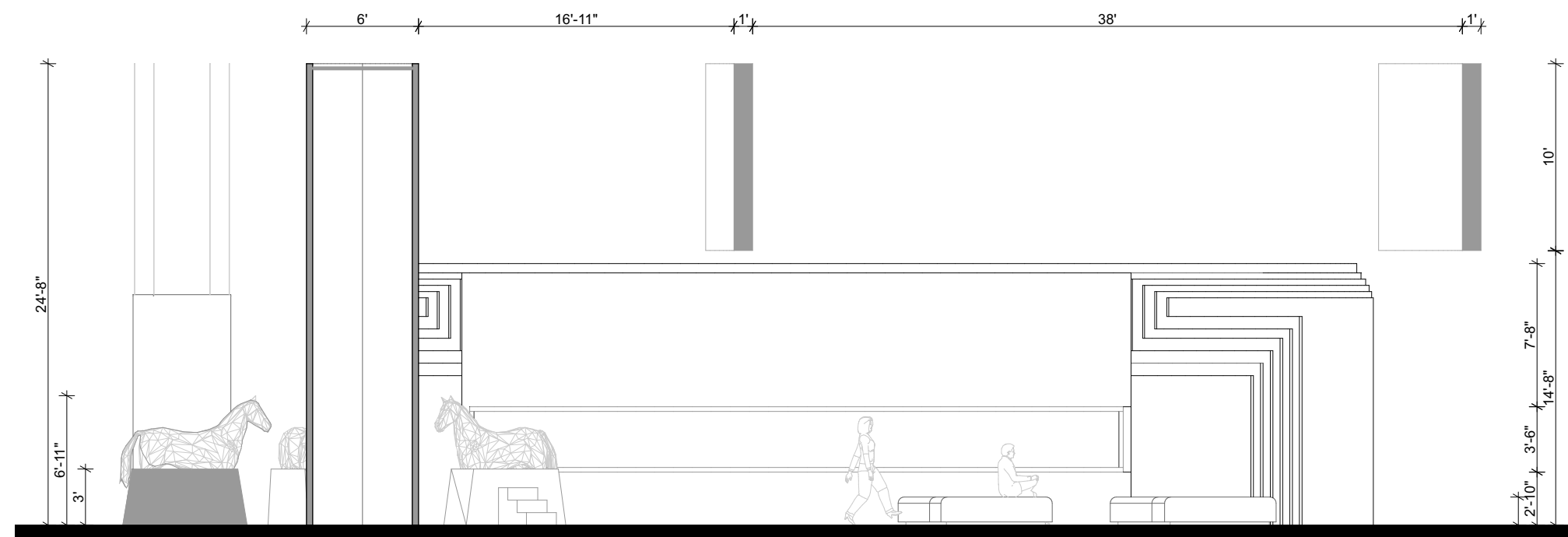

1 **07B SECTION**
scale: 1/8"=1'

GRAPHICS

GRAPHIC LOOK/FEEL

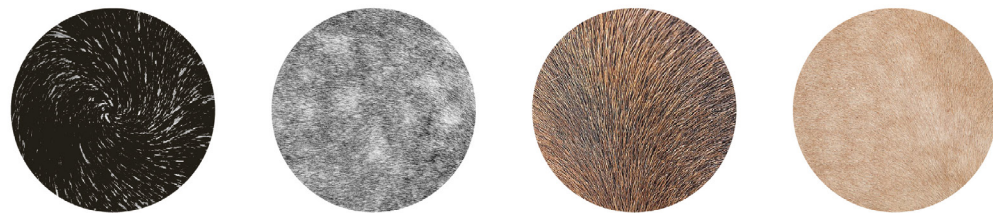

HORSECENTRISM

A relationship of mutual benefit between man and horse

Lorem ipsum dolor sit amet, consectetur adipiscing elit, sed diam nonummy nibh euismod tincidunt ut laoreet dolore magna aliquam erat volutpat. Ut wisi enim ad minim veniam, quis nostrud exerci tation ullamcorper suscipit lobortis nisl ut aliquip ex ea commodo consequat. Duis autem vel eum iriure dolor in hendrerit in vulputate velit esse molestie consequat, vel illum dolore eu feugiat nulla facilisis at vero eros et accumsan et iusto odio dignissim qui blandit praesent luptatum zzril delenit augue dui dolore te feugait nulla facilisi.

Lorem ipsum dolor sit amet, consectetur adipiscing elit, sed diam nonummy nibh euismod tincidunt ut laoreet dolore magna aliquam erat volutpat. Ut wisi enim ad minim veniam, quis nostrud exerci tation ullamcorper suscipit lobortis nisl ut aliquip ex ea commodo consequat.



PROJECT
HORSECENTRISM
THESIS CAPSTONE EXHIBIT

DRAWN BY
FLAVIA PEDROSA TONIETTO

SITE
**PARK AVENUE ARMORY
NEW YORK**



KEY PLAN

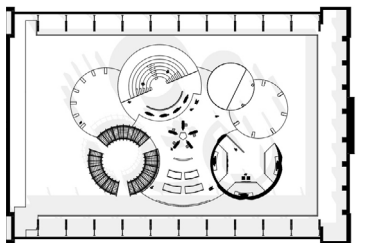

NOTES
DRAWINGS FOR
DESIGN INTENT
ONLY

DRAWING
GRAPHIC LOOK / FEEL

SCALE
NTS

DATE
DEC.06.2023

DRAWING NO
ex4.01

GRAPHIC IDENTITY

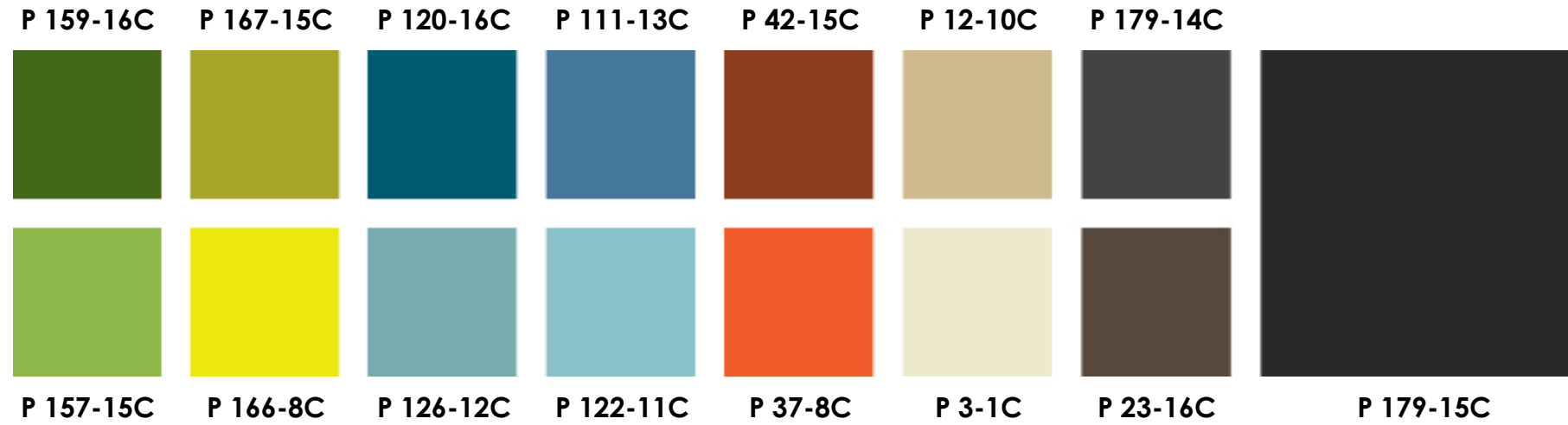

Century Gothic Pro Bold

abcdefghijklmnopqrstuvwxyz
 ABCDEFGHIJKLMNOPQRSTUVWXYZ
 1234567890

Century Gothic Pro Regular

abcdefghijklmnopqrstuvwxyz
 ABCDEFGHIJKLMNOPQRSTUVWXYZ
 1234567890



PROJECT
HORSECENTRISM
 THESIS CAPSTONE EXHIBIT

DRAWN BY
FLAVIA PEDROSA TONIETTO

SITE
**PARK AVENUE ARMORY
 NEW YORK**

CLIENTS



KEY PLAN

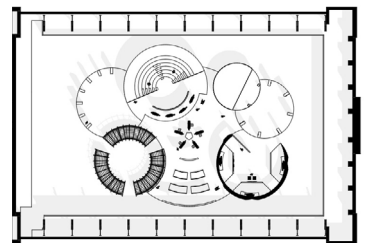

NOTES
 DRAWINGS FOR
 DESIGN INTENT
 ONLY

DRAWING
GRAPHIC IDENTITY

SCALE
 NTS

DRAWING NO
ex4.02

DATE
DEC.06.2023



PROJECT
HORSECENTRISM
THESIS CAPSTONE
EXHIBIT

DRAWN BY
FLAVIA PEDROSA TONIETTO

SITE
**PARK AVENUE ARMORY
NEW YORK**

CLIENTS



KEY PLAN

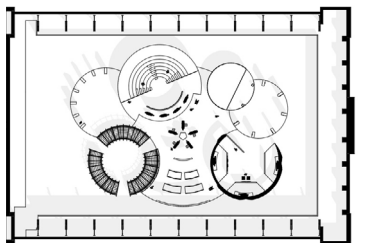

NOTES
DRAWINGS FOR
DESIGN INTENT
ONLY

DRAWING
LOGO

SCALE
NTS

DRAWING NO
EX4.03

DATE
DEC.06.2023



PROJECT
HORSECENTRISM
THESIS CAPSTONE
EXHIBIT

DRAWN BY
FLAVIA PEDROSA TONIETTO

SITE
**PARK AVENUE ARMORY
NEW YORK**



KEY PLAN

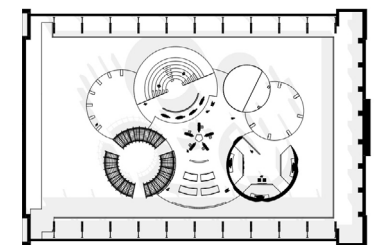

NOTES
DRAWINGS FOR
DESIGN INTENT
ONLY

DRAWING
COLLATERAL

SCALE
NTS

DRAWING NO
EX4.04

DATE
DEC.06.2023





PROJECT
HORSECENTRISM
THESIS CAPSTONE
EXHIBIT

DRAWN BY
FLAVIA PEDROSA TONIETTO

SITE
**PARK AVENUE ARMORY
NEW YORK**

CLIENTS



KEY PLAN

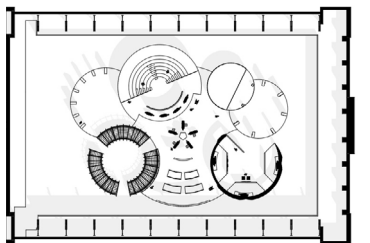

NOTES
DRAWINGS FOR
DESIGN INTENT
ONLY

DRAWING
POSTER

SCALE
NTS

DRAWING NO
EX4.05

DATE
DEC.06.2023

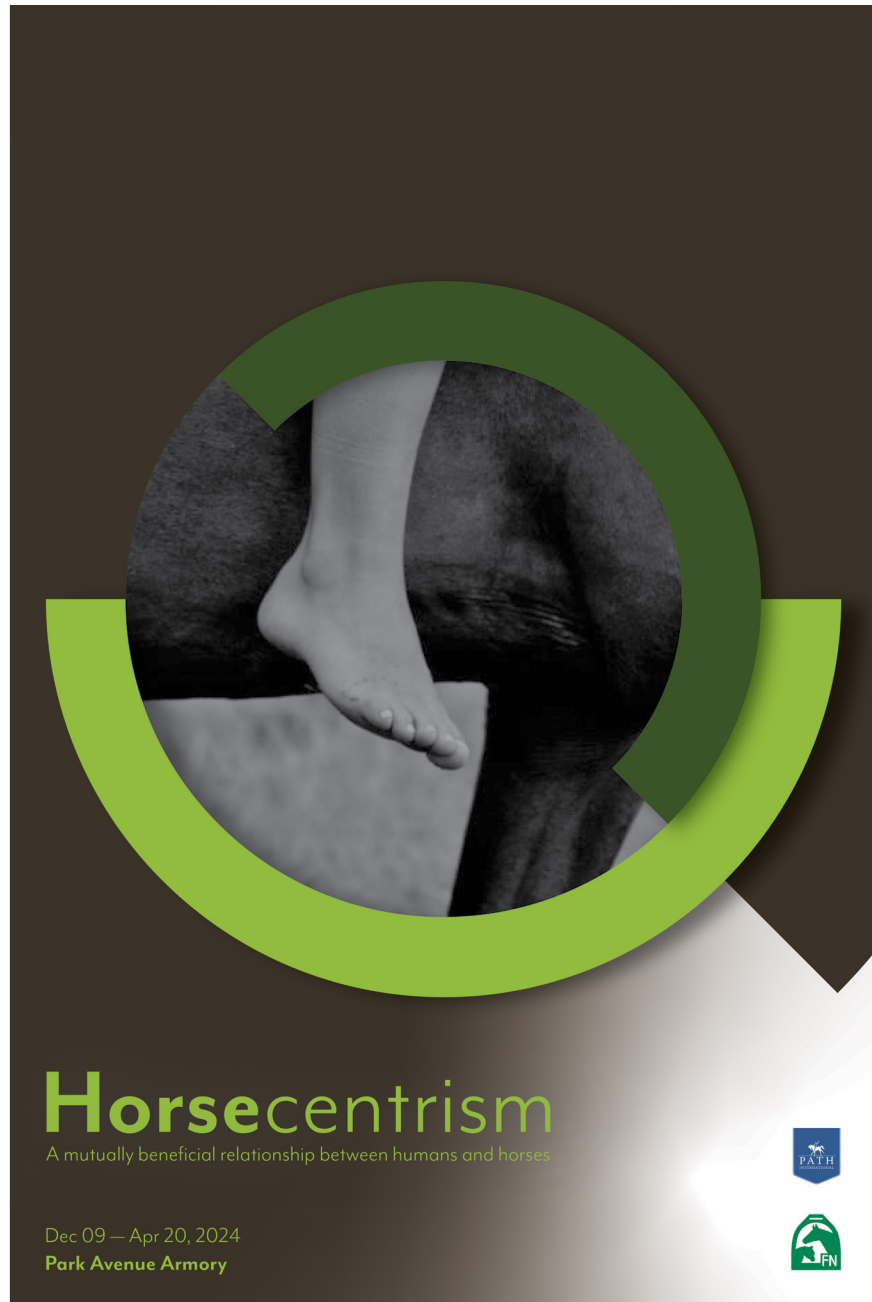
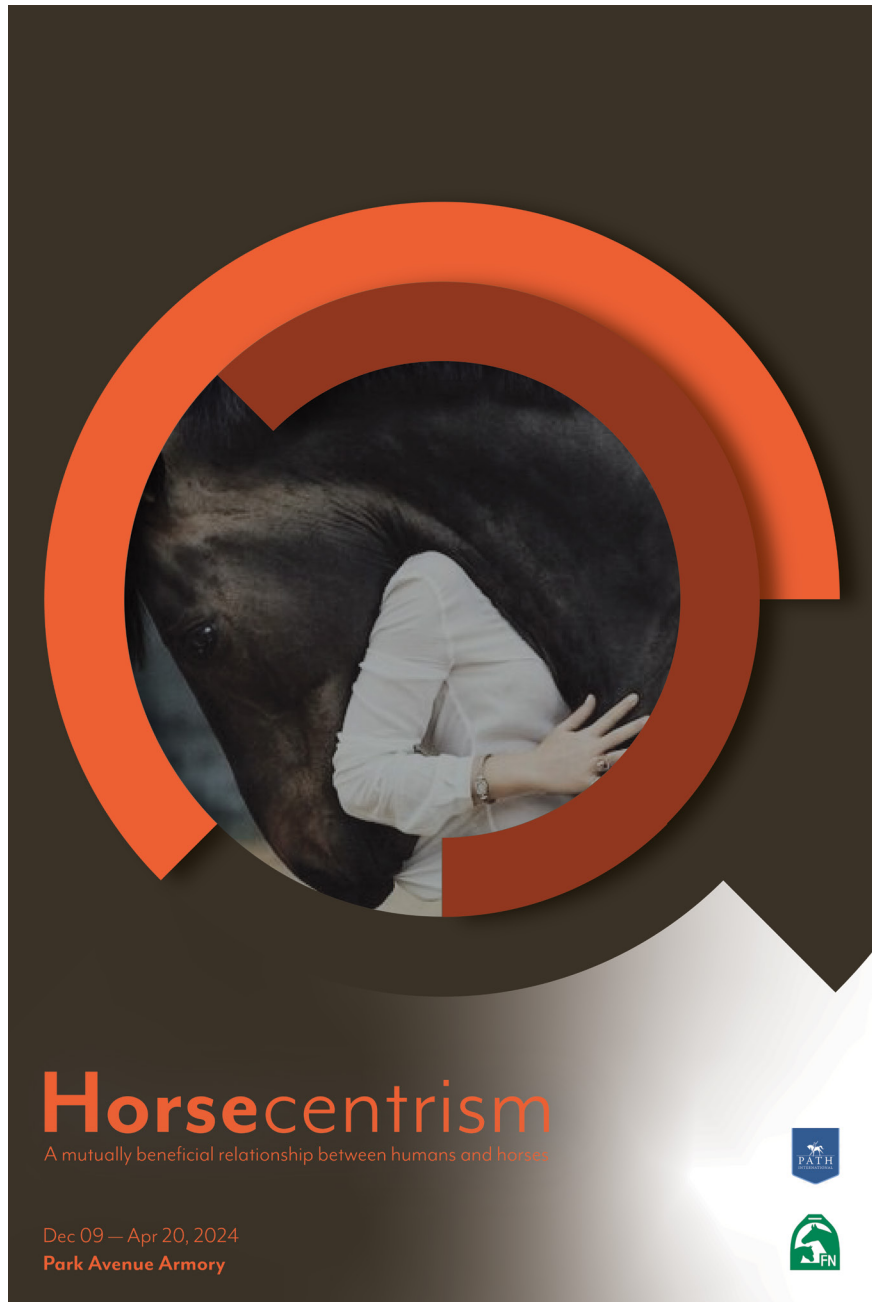



PROJECT
HORSECENTRISM
THESIS CAPSTONE
EXHIBIT

DRAWN BY
FLAVIA PEDROSA TONIETTO

SITE
**PARK AVENUE ARMORY
NEW YORK**



KEY PLAN

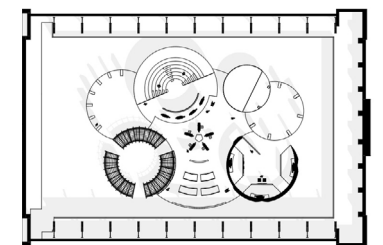

NOTES
DRAWINGS FOR
DESIGN INTENT
ONLY

DRAWING
POSTER APPLIED

SCALE
NTS

DRAWING NO
EX4.06

DATE
DEC.06.2023





PROJECT
HORSECENTRISM
THESIS CAPSTONE
EXHIBIT

DRAWN BY
FLAVIA PEDROSA TONIETTO

SITE
**PARK AVENUE ARMORY
NEW YORK**

CLIENTS



KEY PLAN

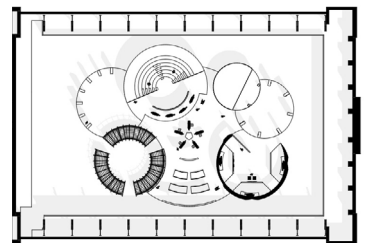

NOTES
DRAWINGS FOR
DESIGN INTENT
ONLY

DRAWING
POSTER APPLIED
CONT'D

SCALE
NTS

DRAWING NO
ex4.07

DATE
DEC.06.2023



PROJECT
HORSECENTRISM
THESIS CAPSTONE
EXHIBIT

DRAWN BY
FLAVIA PEDROSA TONIETTO

SITE
**PARK AVENUE ARMORY
NEW YORK**



KEY PLAN

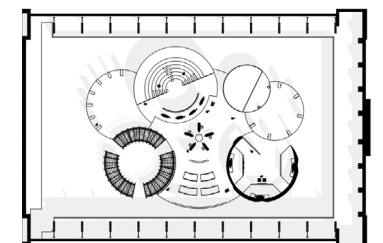

NOTES
DRAWINGS FOR
DESIGN INTENT
ONLY

DRAWING
POSTER APPLIED
CONT'D

SCALE
NTS

DRAWING NO
ex4.08

DATE
DEC.06.2023





PROJECT
HORSECENTRISM
THESIS CAPSTONE
EXHIBIT

DRAWN BY
FLAVIA PEDROSA TONIETTO

SITE
**PARK AVENUE ARMORY
NEW YORK**

CLIENTS



KEY PLAN

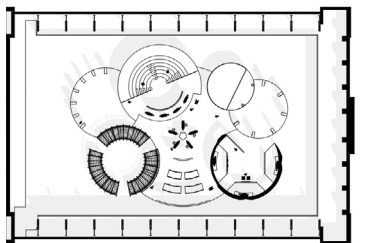

NOTES
DRAWINGS FOR
DESIGN INTENT
ONLY

DRAWING
POSTER APPLIED
CONT'D

SCALE
NTS

DRAWING NO
ex4.09

DATE
DEC.06.2023



PROJECT
HORSECENTRISM
THESIS CAPSTONE
EXHIBIT

DRAWN BY
FLAVIA PEDROSA TONIETTO

SITE
**PARK AVENUE ARMORY
NEW YORK**

CLIENTS



KEY PLAN

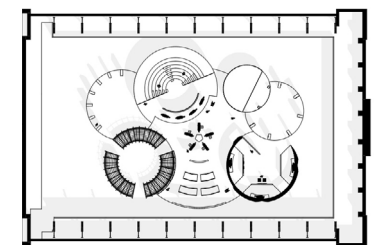

NOTES
DRAWINGS FOR
DESIGN INTENT
ONLY

DRAWING
WAYFINDING

SCALE
AS NOTED

DATE
DEC.06.2023

DRAWING NO
EX4.10

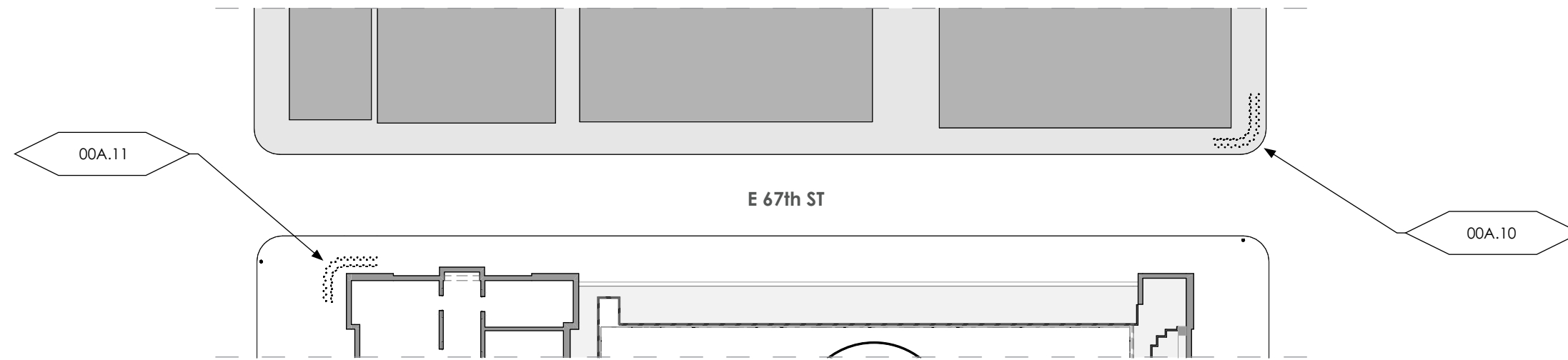

1 **TOP VIEW STREET LEVEL 00A.09-00A.11**
scale: 1/64"=1'

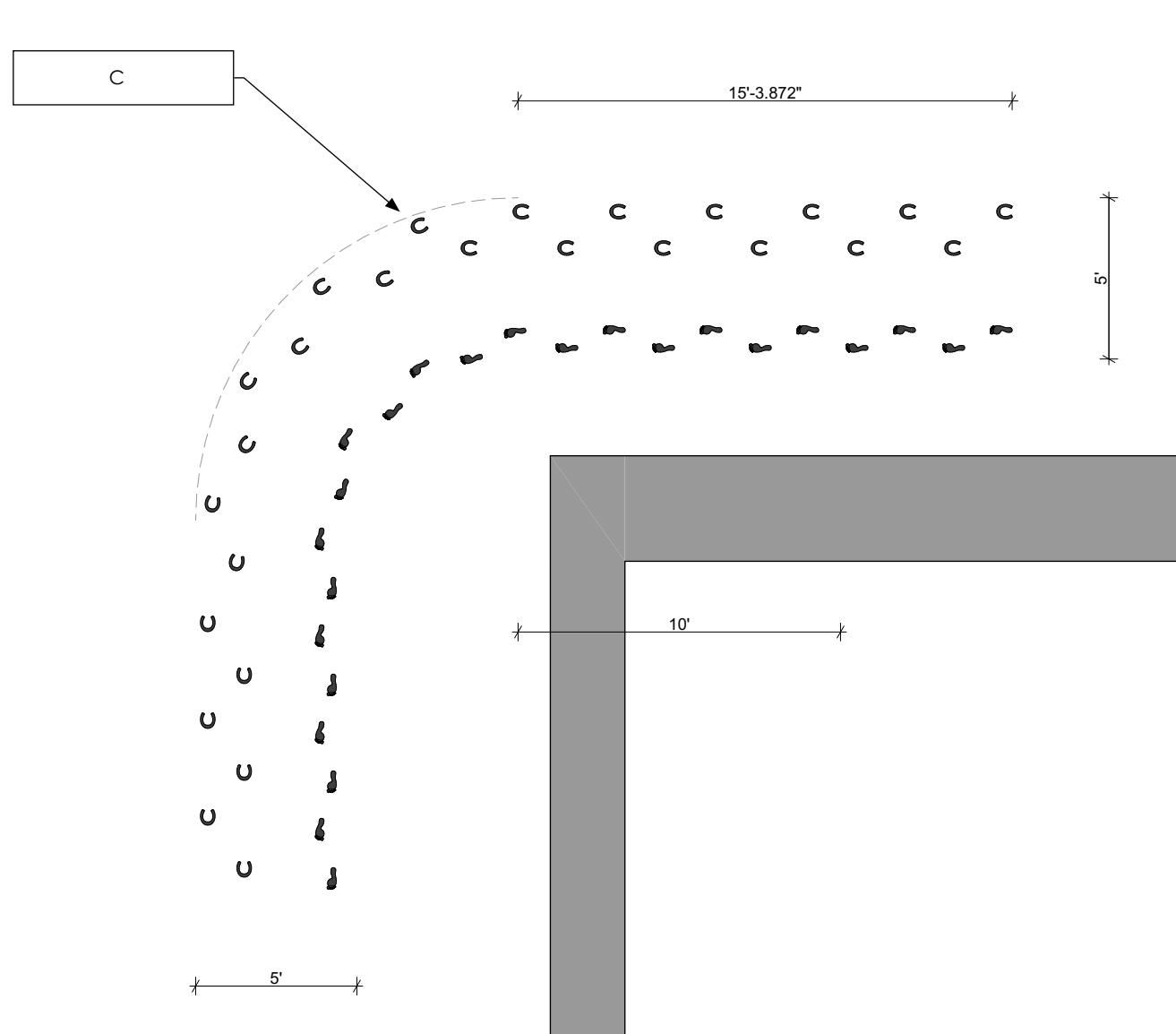

1 **DETAIL 00A.11**
scale: 3/16"=1'

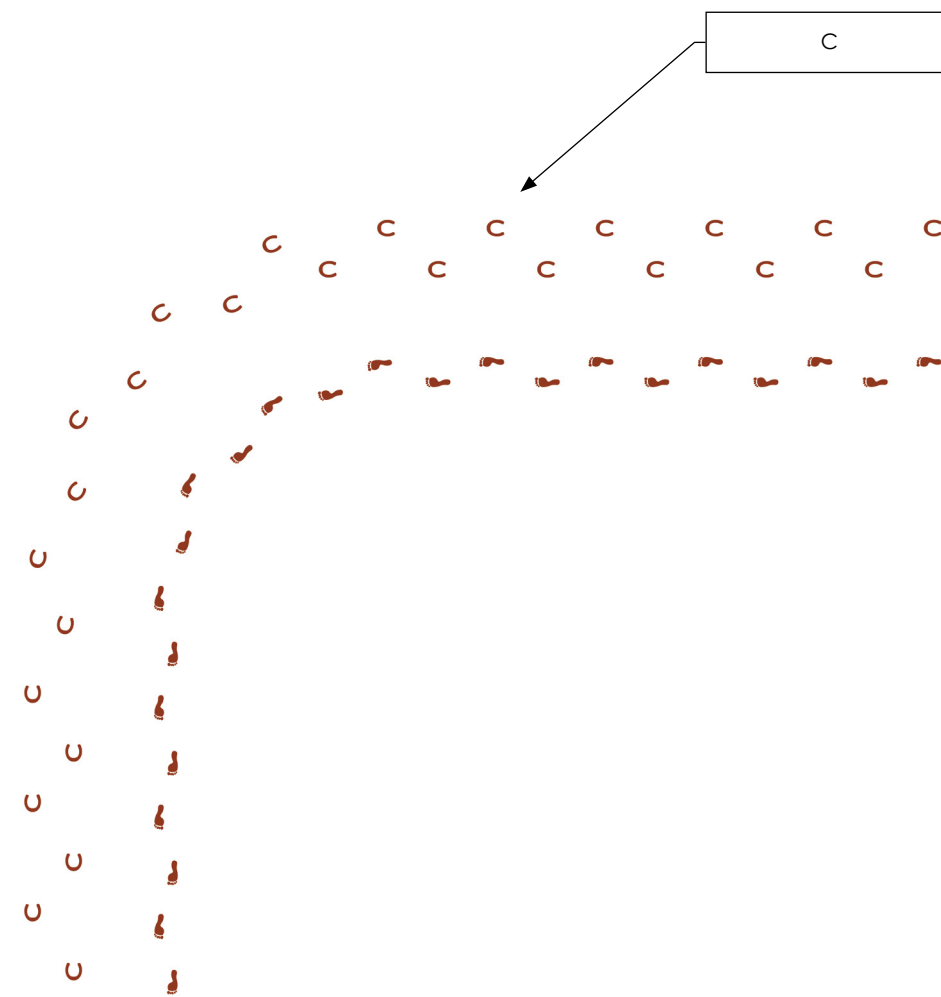

1 **DETAIL 00A.11 COLORED - P 42-15C**
scale: 3/16"=1'



PROJECT
HORSECENTRISM
THESIS CAPSTONE
EXHIBIT

DRAWN BY
FLAVIA PEDROSA TONIETTO

SITE
**PARK AVENUE ARMORY
NEW YORK**



KEY PLAN

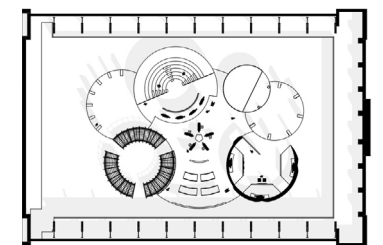

NOTES
DRAWINGS FOR
DESIGN INTENT
ONLY

DRAWING
WAYFINDING CONT'D

SCALE
1"=1'

DATE
DEC.06.2023

DRAWING NO
EX4.11

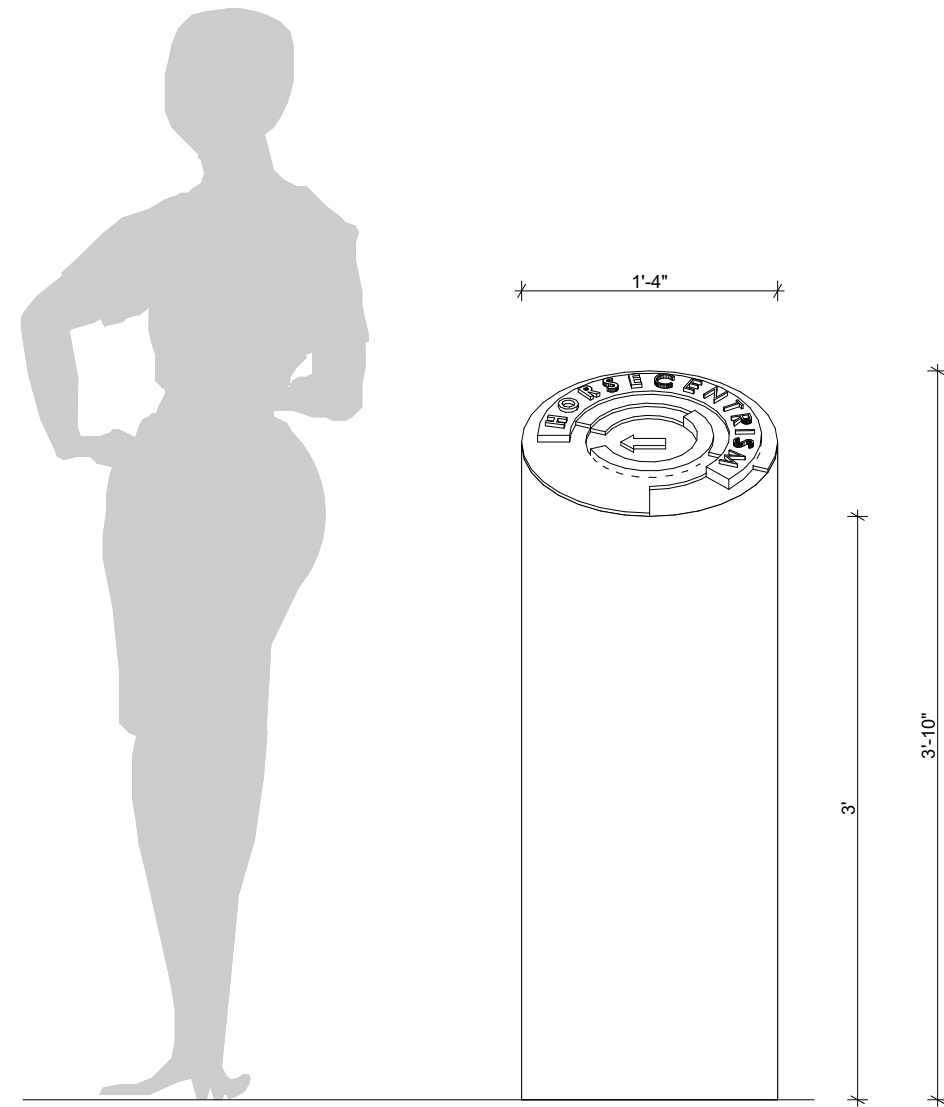

1 **FRONT VIEW 00A.05-00A.08**
scale: 1"=1'

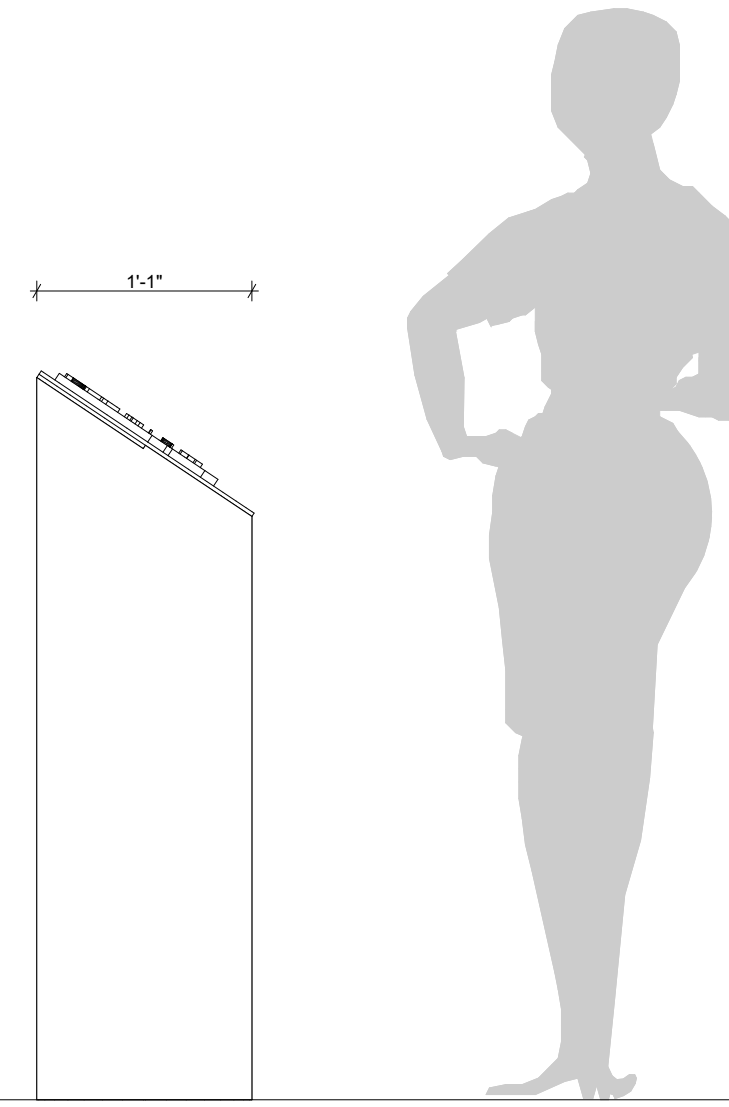

1 **SIDE VIEW 00A.05-00A.08**
scale: 1"=1'

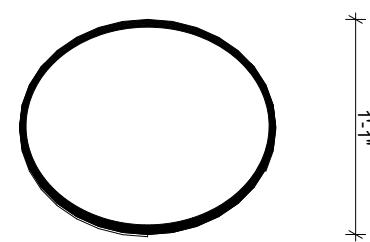

1 **PLAN 00A.05-00A.08**
scale: 1"=1'

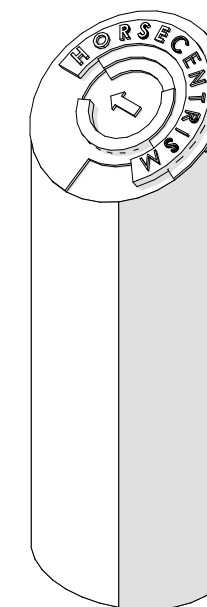

1 **AXONOMETRIC 00A.05-00A.08**



PROJECT
HORSECENTRISM
THESIS CAPSTONE
EXHIBIT

DRAWN BY
FLAVIA PEDROSA TONIETTO

SITE
**PARK AVENUE ARMORY
NEW YORK**



KEY PLAN

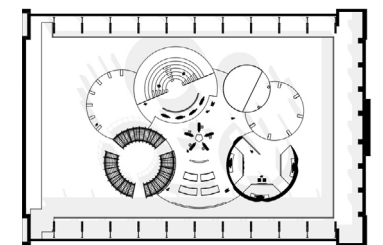

NOTES
DRAWINGS FOR
DESIGN INTENT
ONLY

DRAWING
WAYFINDING CONT'D

SCALE
1/4"=1'

DATE
DEC.06.2023

DRAWING NO
EX4.12



1 **FRONT VIEW 00A.01-00A.04**
scale: 1/4"=1'

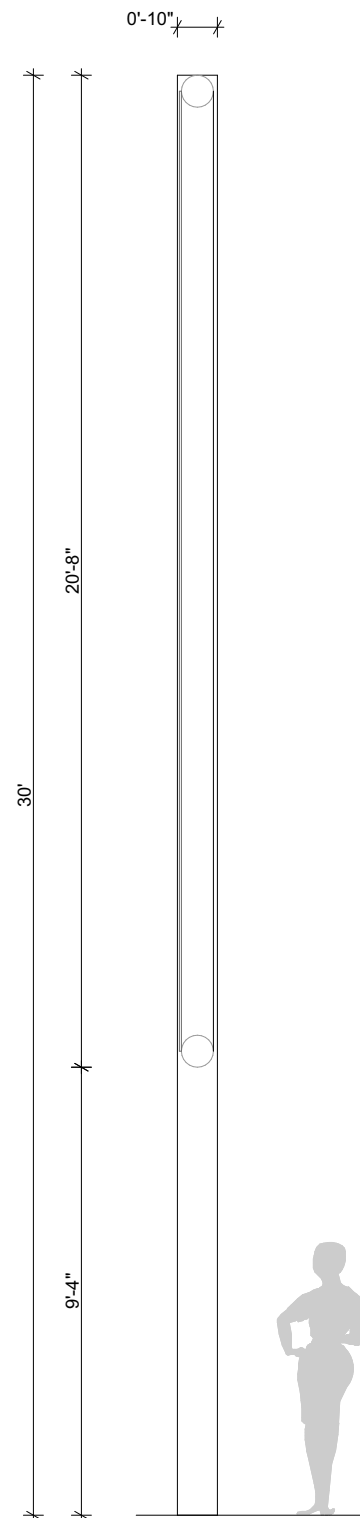

1 **SIDE VIEW 00A.01-00A.04**
scale: 1/4"=1'



1 **AXONOMETRIC 00A.01-00A.04**

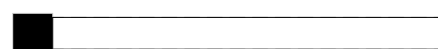
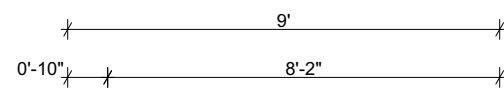

1 **PLAN 00A.01-00A.04**
scale: 1/4"=1'



PROJECT
HORSECENTRISM
THESIS CAPSTONE
EXHIBIT

DRAWN BY
FLAVIA PEDROSA TONIETTO

SITE
**PARK AVENUE ARMORY
NEW YORK**



KEY PLAN

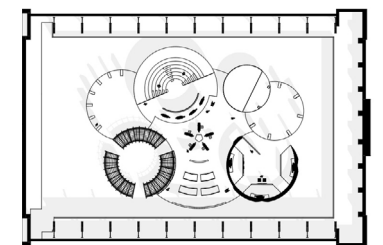

NOTES
DRAWINGS FOR
DESIGN INTENT
ONLY

DRAWING
INTRODUCTION GRAPHIC

SCALE
3/4"=1'

DATE
DEC.06.2023

DRAWING NO
EX4.13

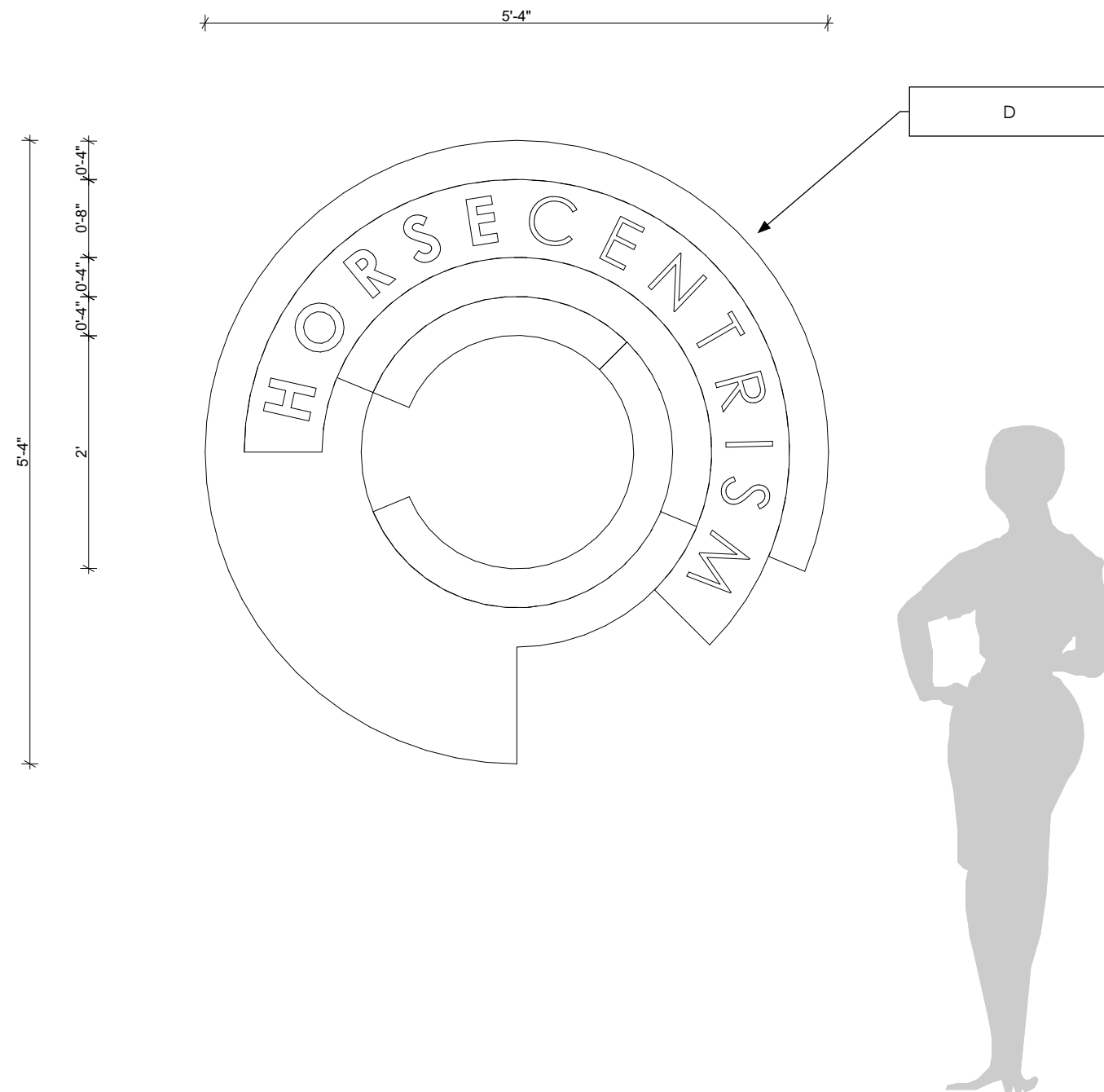

1 **FRONT VIEW 00B.01**
scale: 3/4"=1'

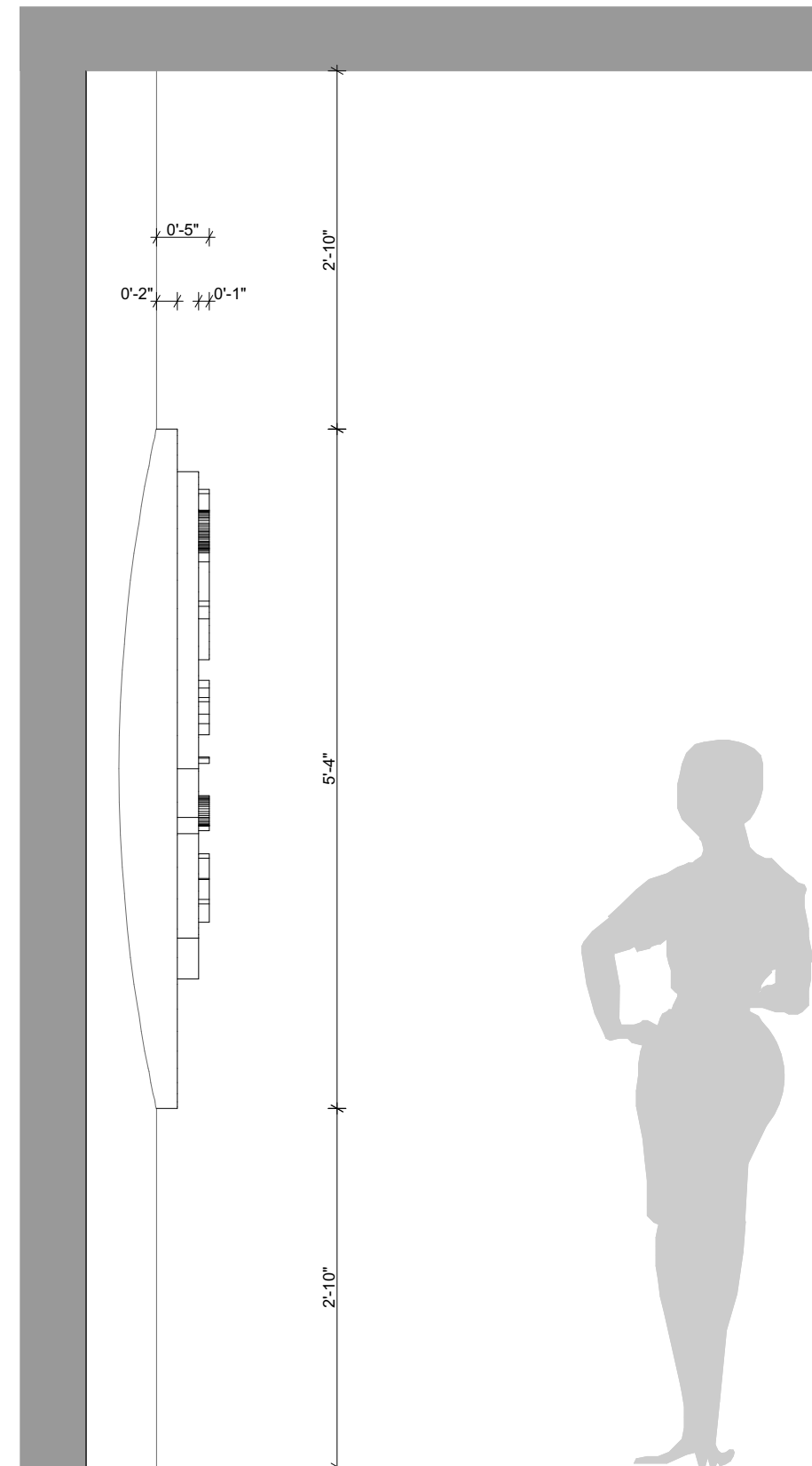

1 **SIDE VIEW 00B.01**
scale: 3/4"=1'



PROJECT
HORSECENTRISM
THESIS CAPSTONE
EXHIBIT

DRAWN BY
FLAVIA PEDROSA TONIETTO

SITE
**PARK AVENUE ARMORY
NEW YORK**



KEY PLAN

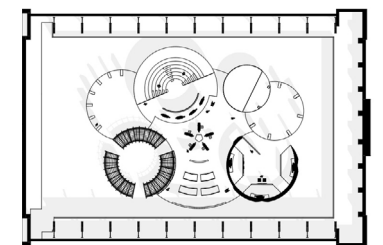

NOTES
DRAWINGS FOR
DESIGN INTENT
ONLY

DRAWING
AREA INTRODUCTION
GRAPHIC

SCALE
3/8"=1'

DATE
DEC.06.2023

DRAWING NO
EX4.14

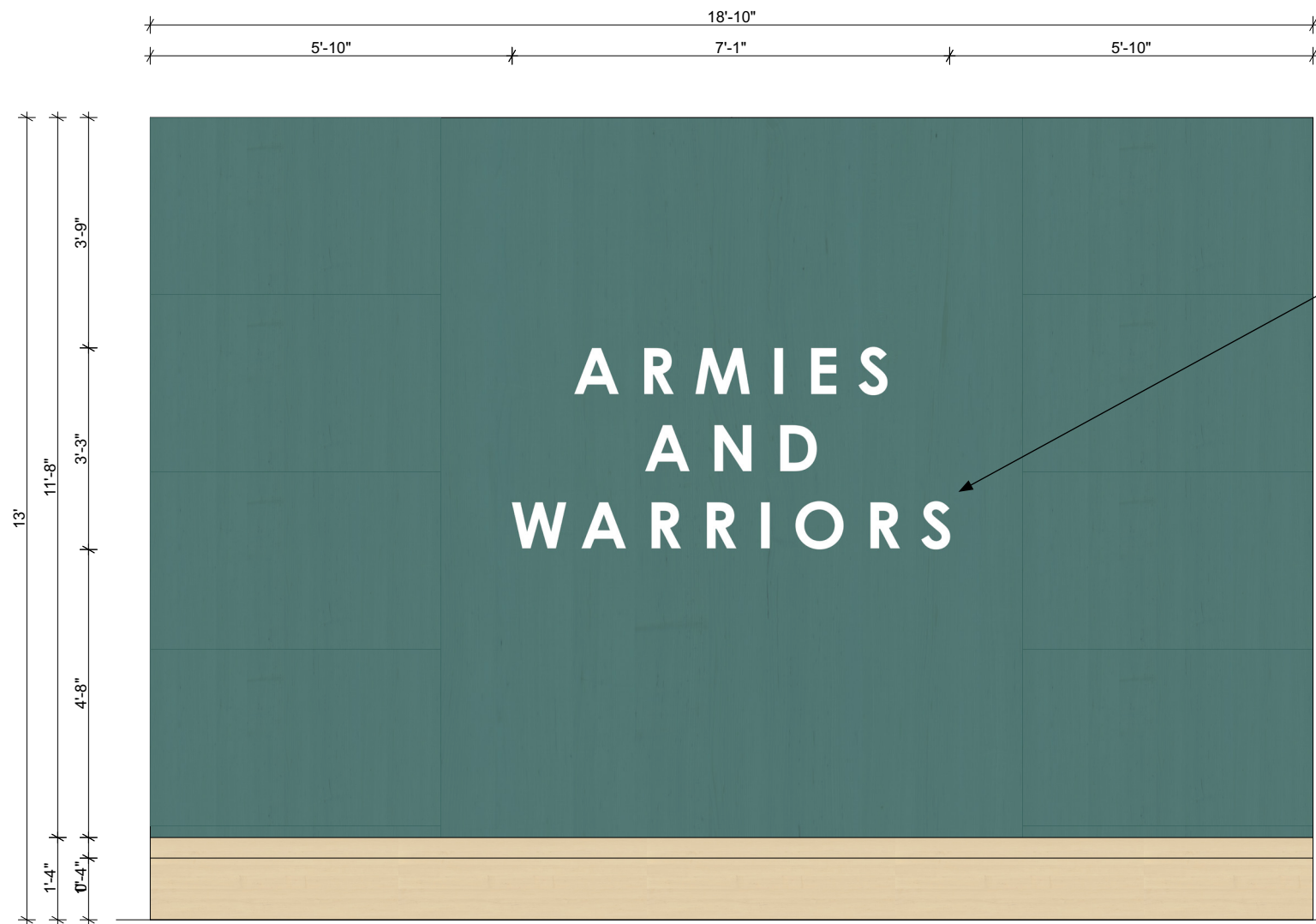

1 UNFOLDED ELEVATION 01B.01
scale: 3/8"=1'

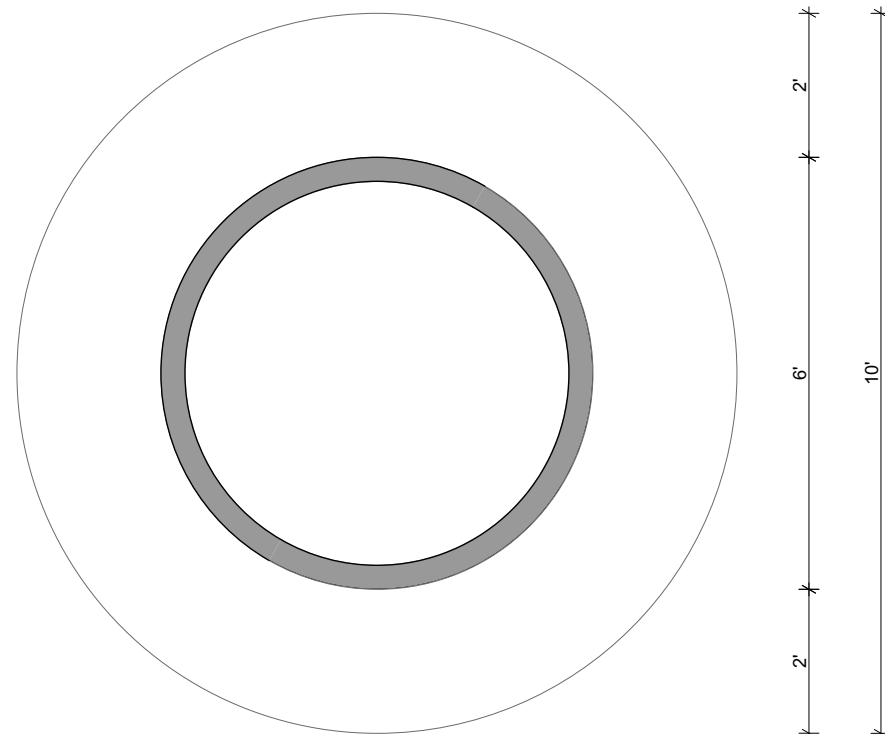

1 PLAN 01B.01
scale: 3/8"=1'

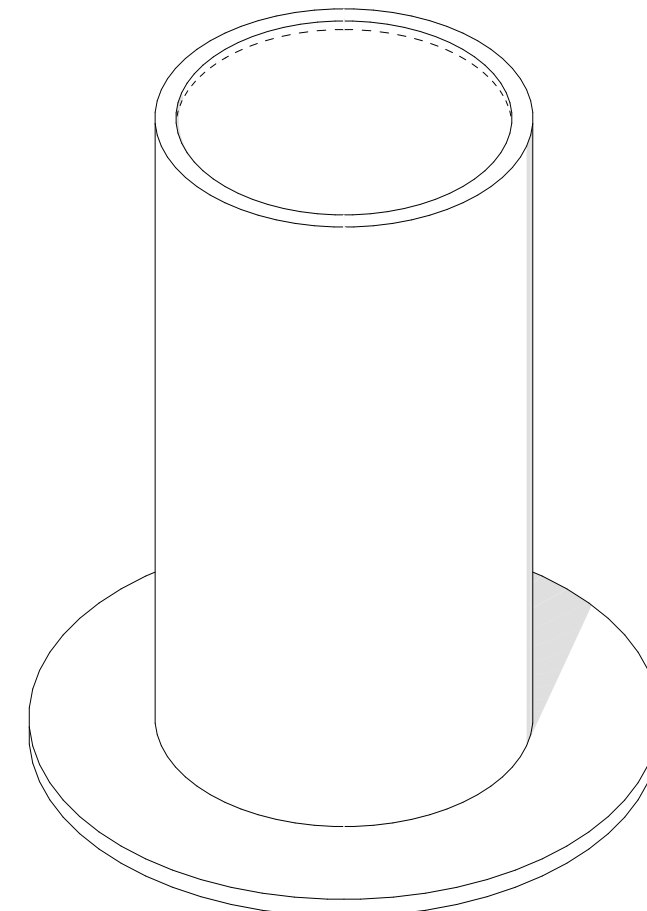

1 AXONOMETRIC 01B.01



PROJECT
HORSECENTRISM
THESIS CAPSTONE
EXHIBIT

DRAWN BY
FLAVIA PEDROSA TONIETTO

SITE
**PARK AVENUE ARMORY
NEW YORK**

CLIENTS



KEY PLAN

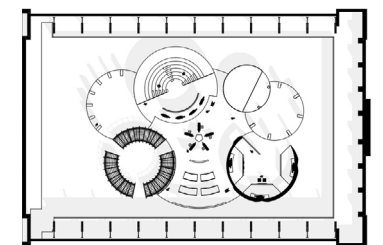

NOTES
DRAWINGS FOR
DESIGN INTENT
ONLY

DRAWING
AREA INTRODUCTION
GRAPHIC CONT'D

SCALE
1/4"=1'

DATE
DEC.06.2023

DRAWING NO
EX4.15

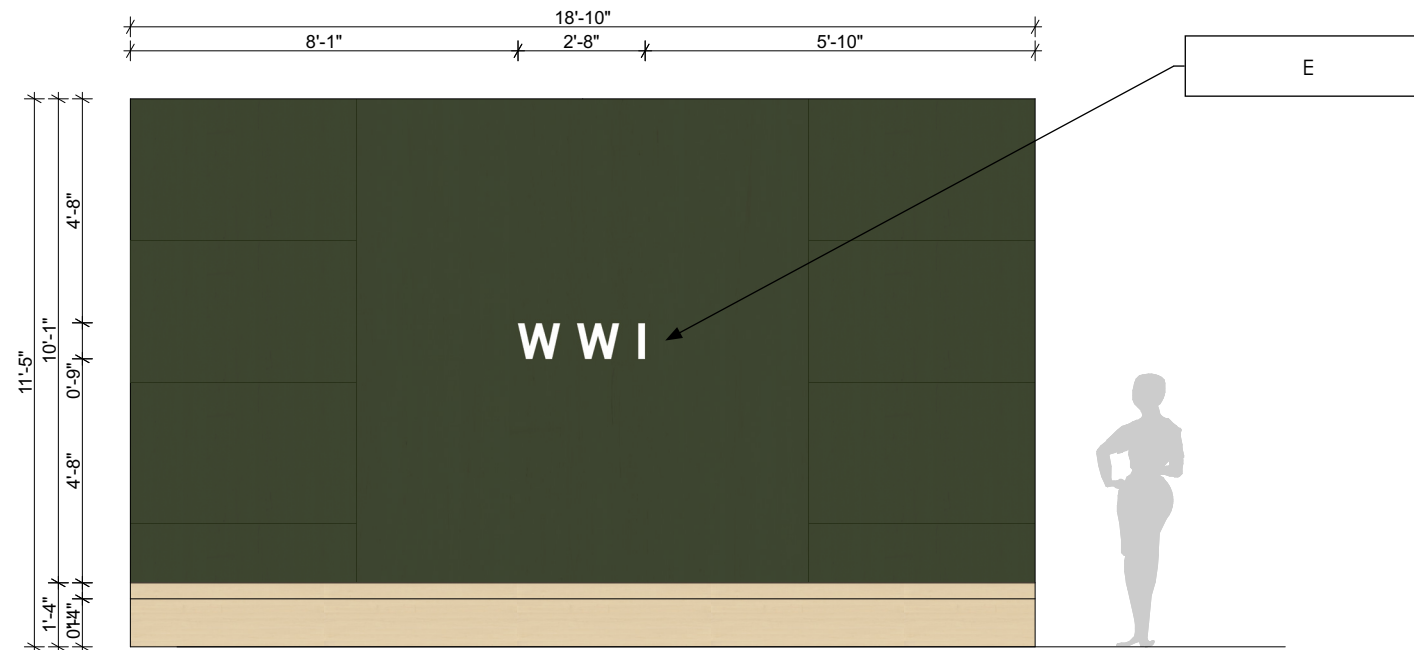

1 UNFOLDED ELEVATION 02B.01
scale: 1/4"=1'

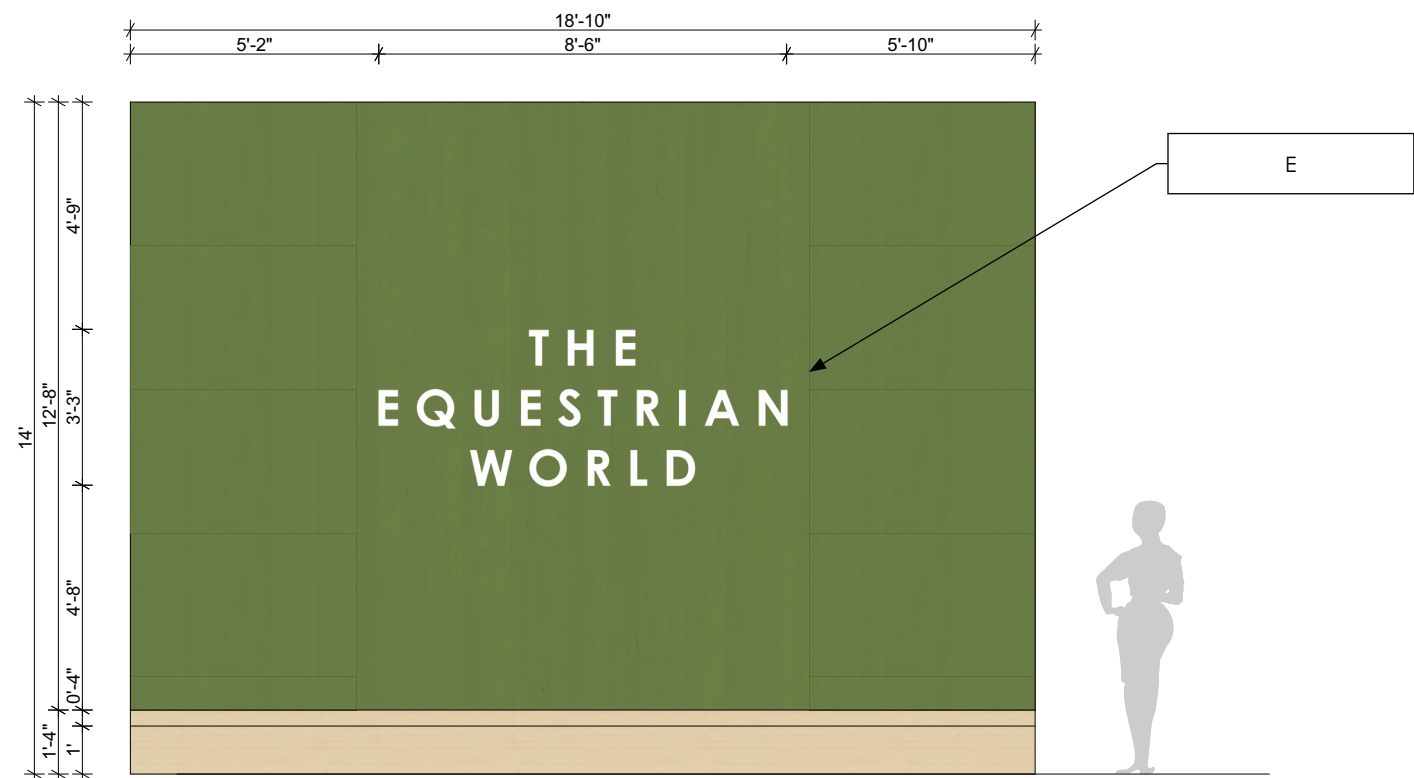

1 UNFOLDED ELEVATION 04B.01
scale: 1/4"=1'

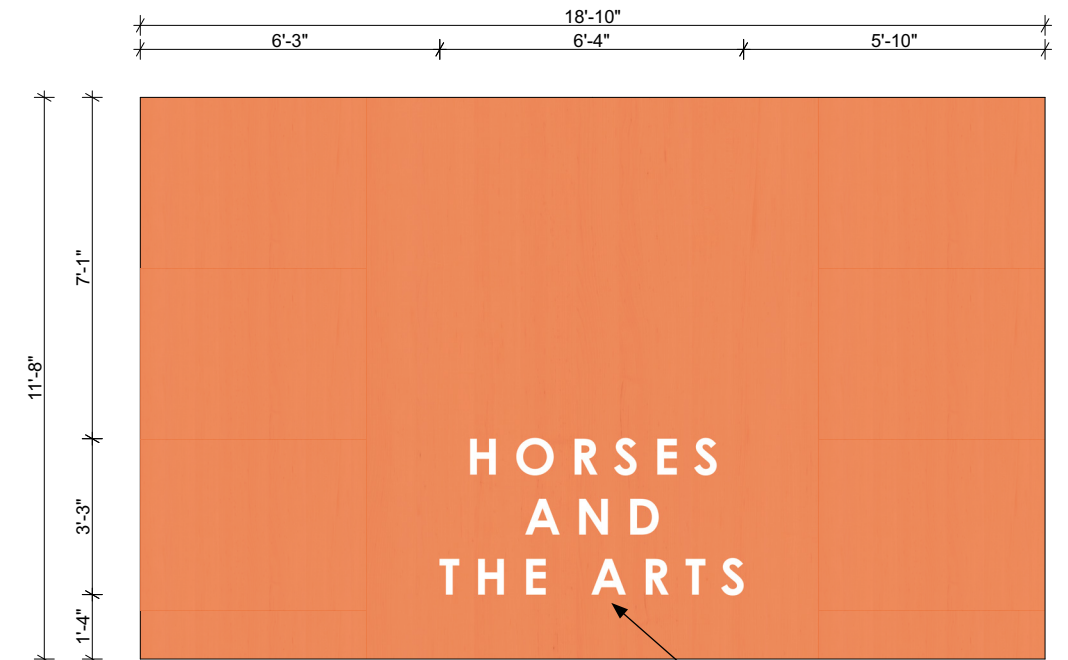

1 UNFOLDED ELEVATION 03B.01
scale: 1/4"=1'



PROJECT
HORSECENTRISM
THESIS CAPSTONE
EXHIBIT

DRAWN BY
FLAVIA PEDROSA TONIETTO

SITE
**PARK AVENUE ARMORY
NEW YORK**



KEY PLAN

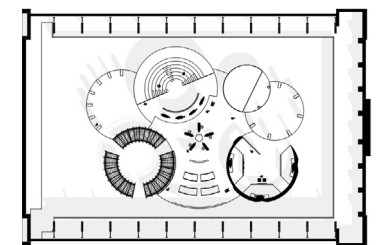

NOTES
DRAWINGS FOR
DESIGN INTENT
ONLY

DRAWING
AREA INTRODUCTION
GRAPHIC CONT'D

SCALE
1/4"=1'

DATE
DEC.06.2023

DRAWING NO
EX4.16

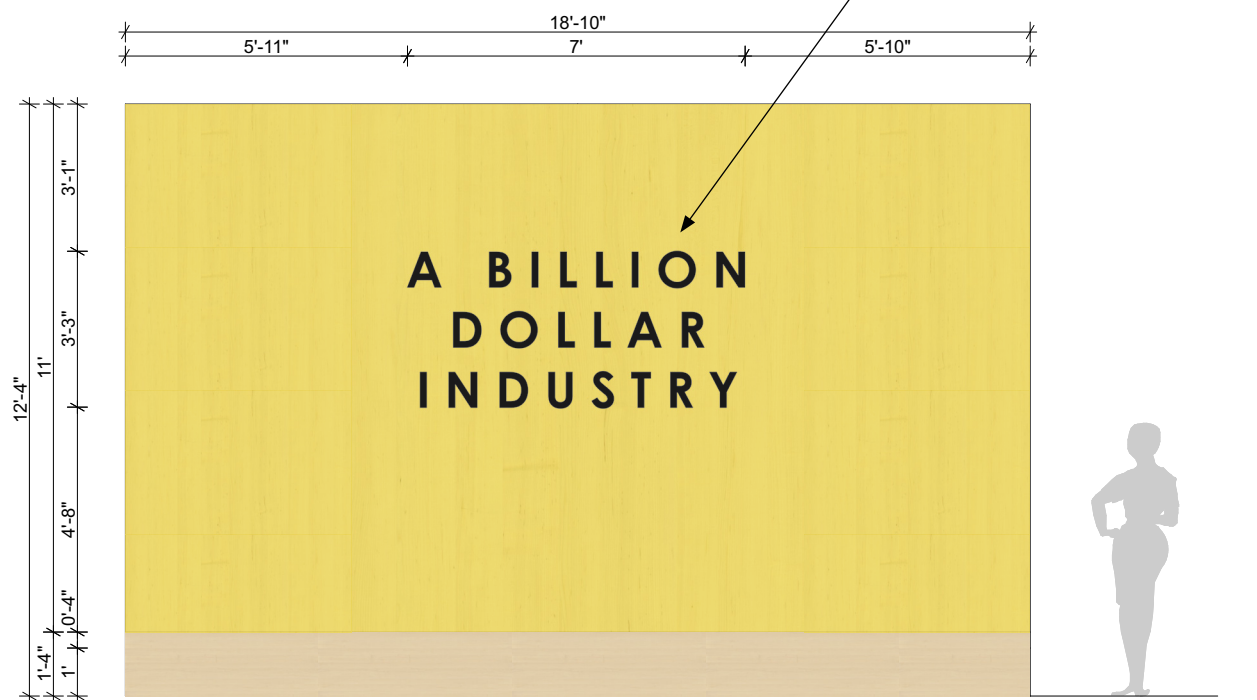

1 UNFOLDED ELEVATION 05B.01
scale: 1/4"=1'

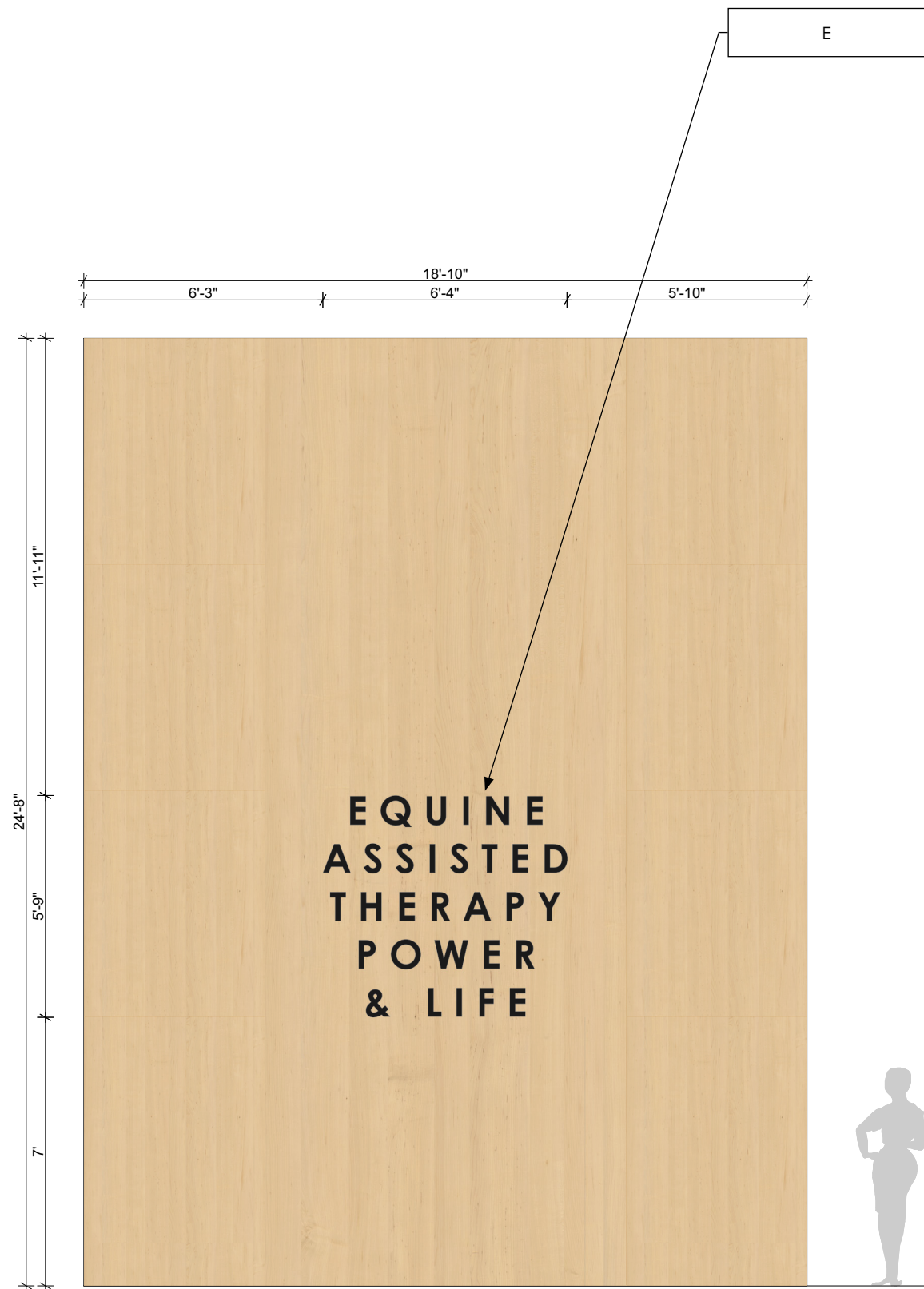

1 UNFOLDED ELEVATION 07B.01
scale: 1/4"=1'



PROJECT
HORSECENTRISM
THESIS CAPSTONE
EXHIBIT

DRAWN BY
FLAVIA PEDROSA TONIETTO

SITE
**PARK AVENUE ARMORY
NEW YORK**



KEY PLAN

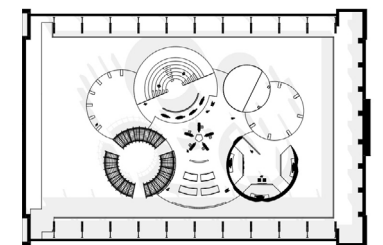

NOTES
DRAWINGS FOR
DESIGN INTENT
ONLY

DRAWING
AREA INTRODUCTION
GRAPHIC CONT'D

SCALE
1/4"=1'

DRAWING NO
EX4.17

DATE
DEC.06.2023

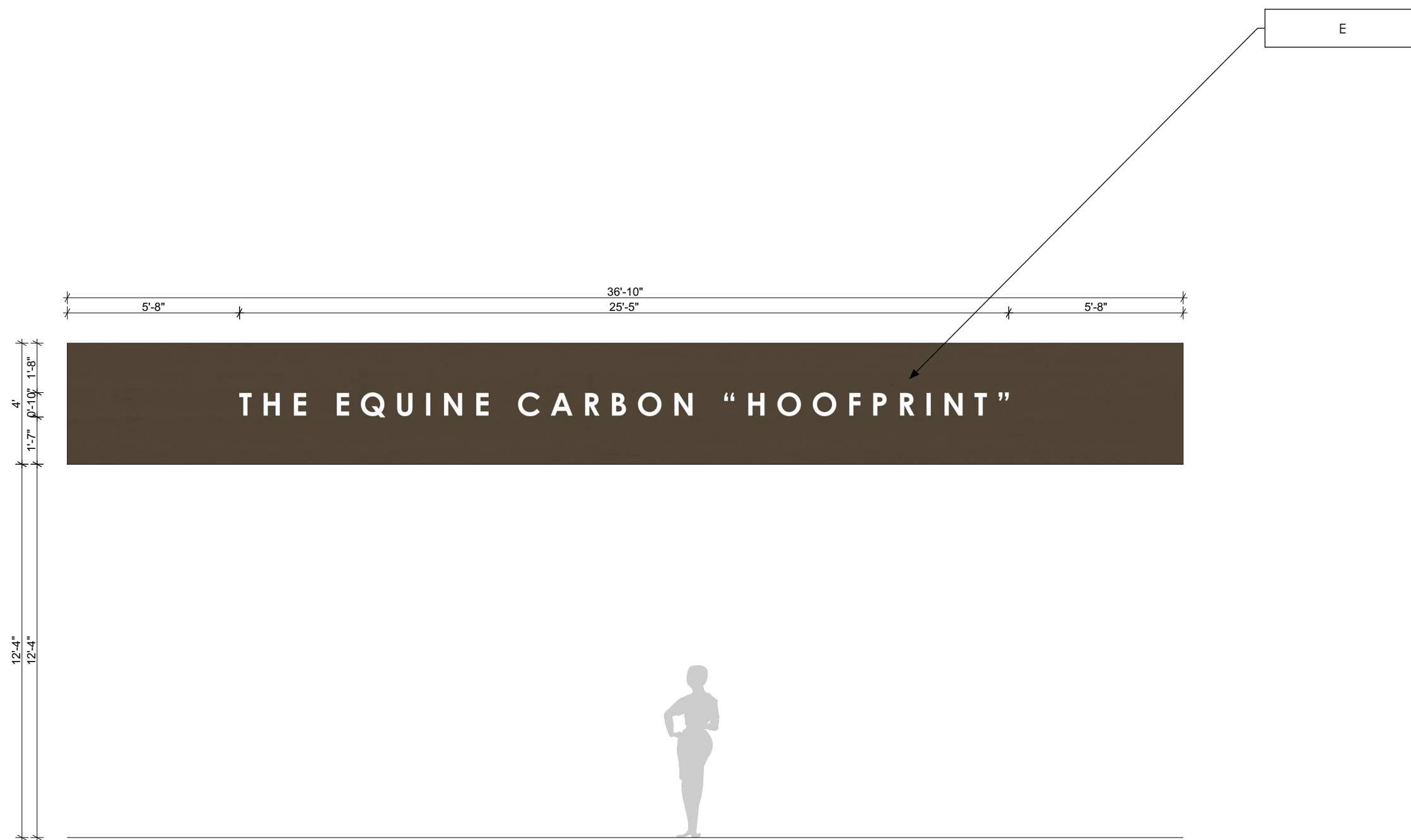

1 **UNFOLDED ELEVATION 06B.01**
scale: 1/4"=1'



PROJECT
HORSECENTRISM
THESIS CAPSTONE
EXHIBIT

DRAWN BY
FLAVIA PEDROSA TONIETTO

SITE
**PARK AVENUE ARMORY
NEW YORK**



KEY PLAN

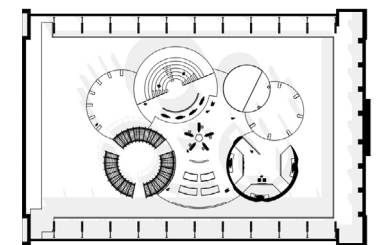

NOTES
DRAWINGS FOR
DESIGN INTENT
ONLY

DRAWING
CONTENT GRAPHICS

SCALE
3/8"=1'

DATE
DEC.06.2023

DRAWING NO
EX4.18

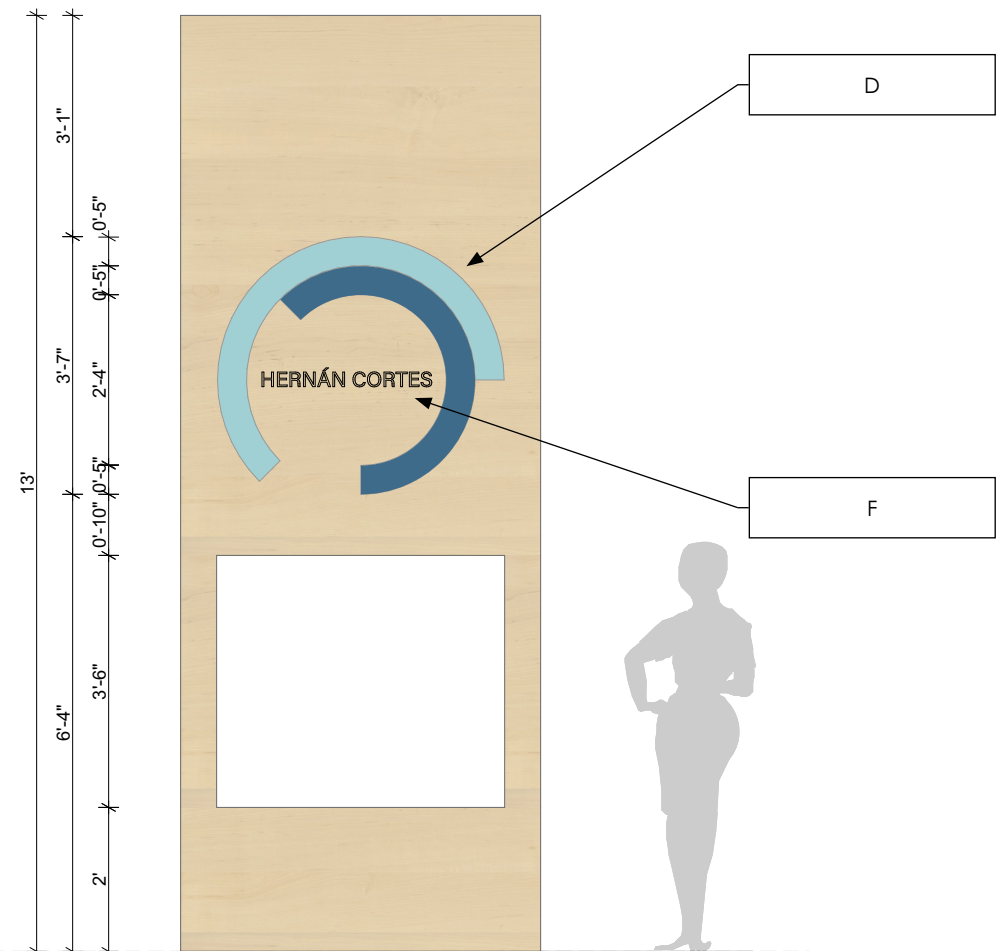
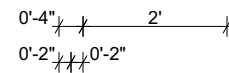
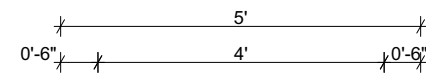

1 **FRONT VIEW** 01B.02.GR01-02
scale: 3/8"=1' 01B.04.GR01-02
01B.06.GR01-02

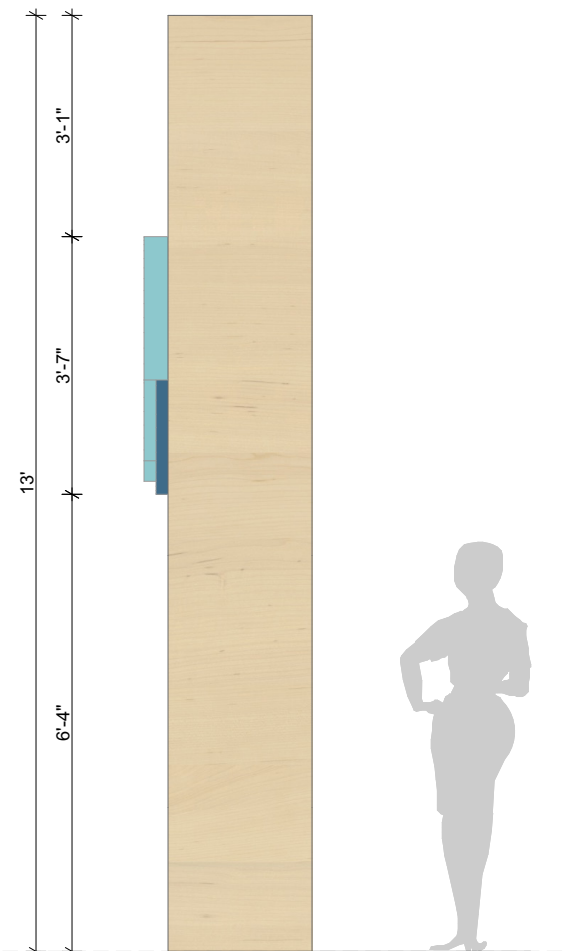

1 **SIDE VIEW** 01B.02.GR01-02
scale: 3/8"=1' 01B.04.GR01-02
01B.06.GR01-02

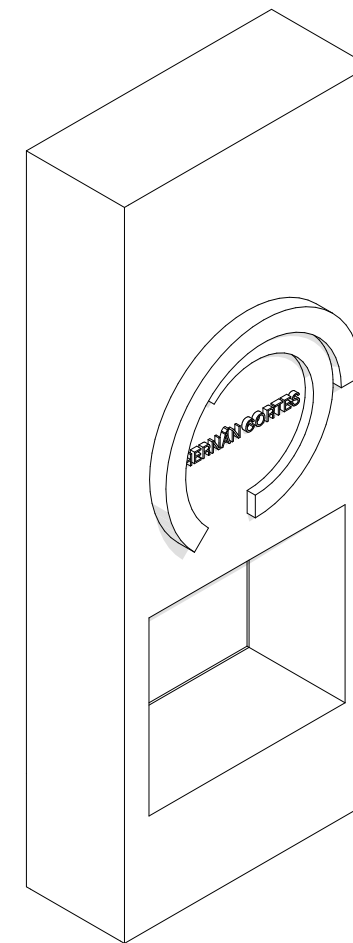

1 **AXONOMETRIC** 01B.02.GR01-02
01B.04.GR01-02
01B.06.GR01-02



PROJECT
HORSECENTRISM
THESIS CAPSTONE
EXHIBIT

DRAWN BY
FLAVIA PEDROSA TONIETTO

SITE
**PARK AVENUE ARMORY
NEW YORK**



KEY PLAN

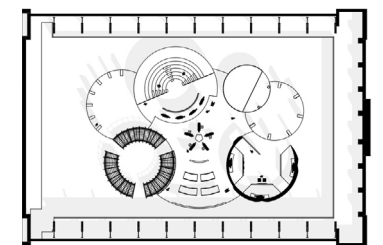

NOTES
DRAWINGS FOR
DESIGN INTENT
ONLY

DRAWING
CONTENT GRAPHICS
CONT'D

SCALE
3/8"=1'

DATE
DEC.06.2023

DRAWING NO
EX4.19

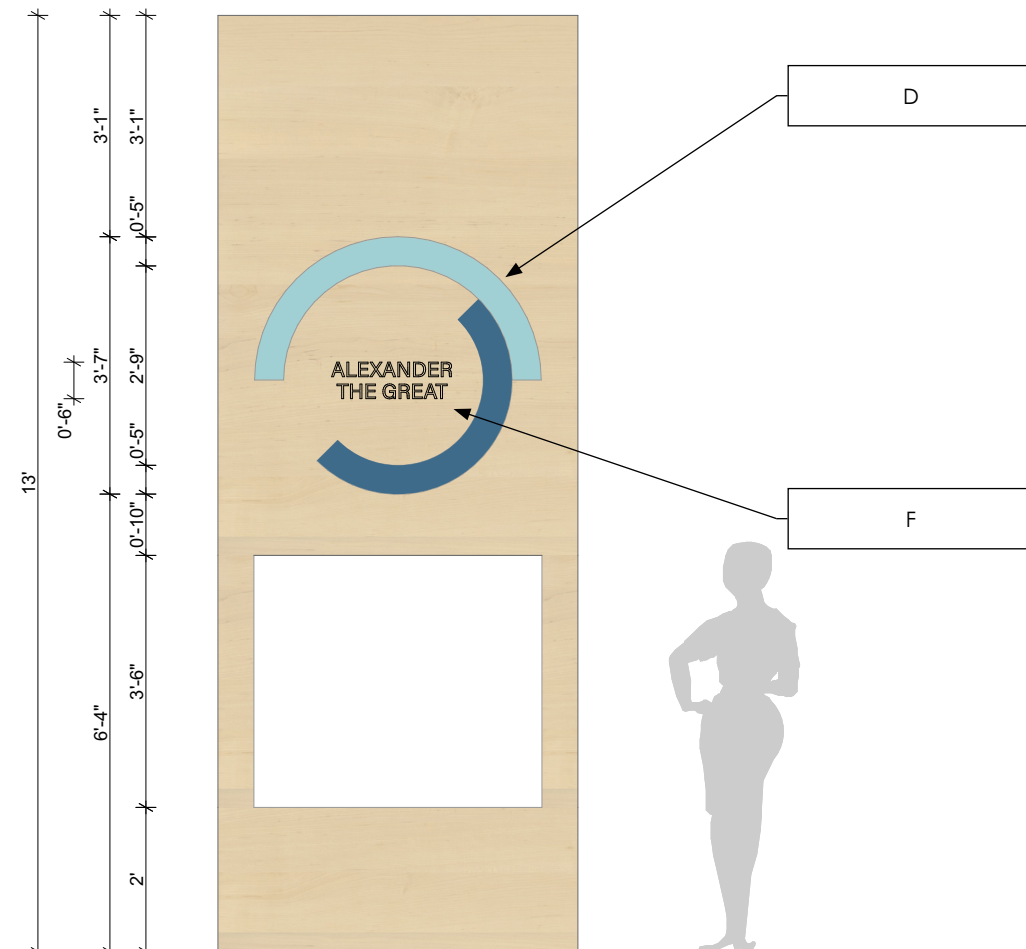
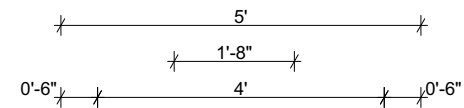

1 **FRONT VIEW** **01B.03.GR01-02**
scale: 3/8"=1' **01B.08.GR01-02**

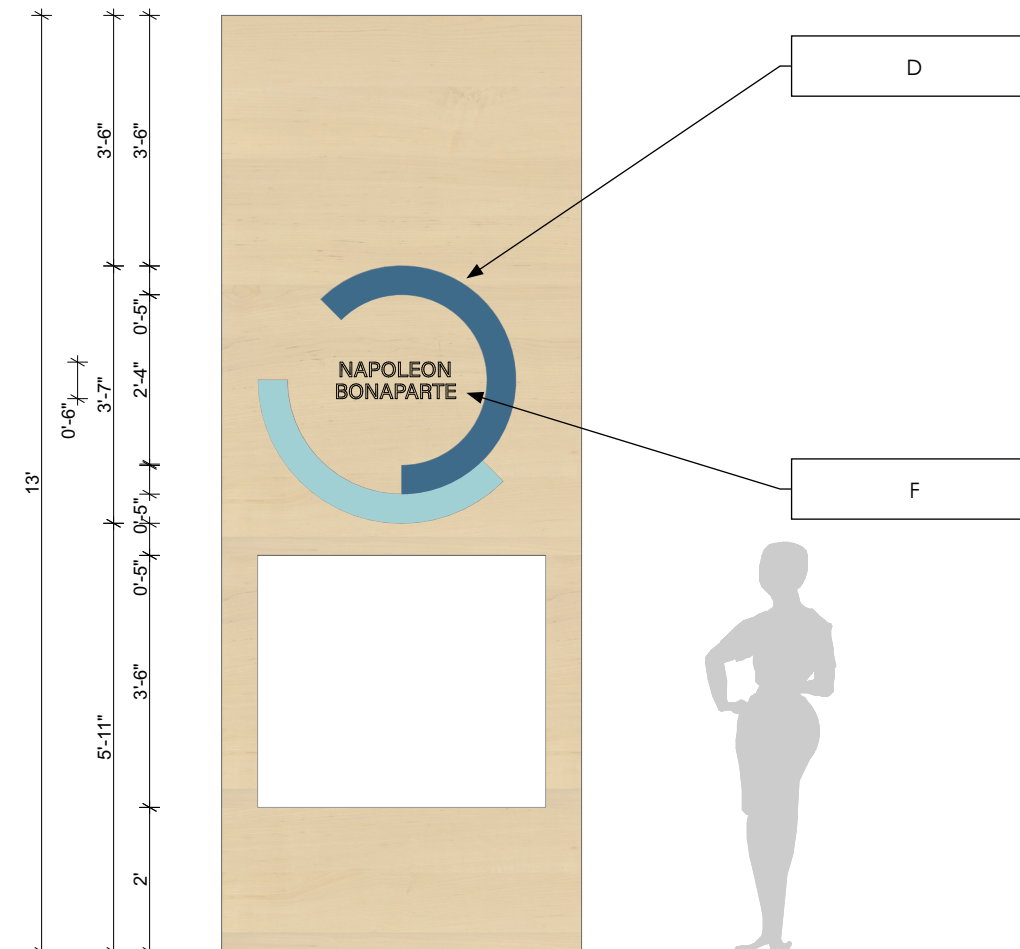
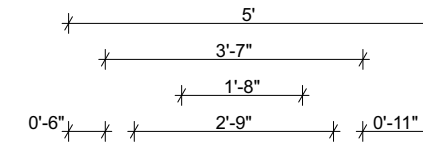

1 **SIDE VIEW** **01B.05.GR01-02**
scale: 3/8"=1' **01B.07.GR01-02**



PROJECT
HORSECENTRISM
THESIS CAPSTONE
EXHIBIT

DRAWN BY
FLAVIA PEDROSA TONIETTO

SITE
**PARK AVENUE ARMORY
NEW YORK**

CLIENTS



KEY PLAN

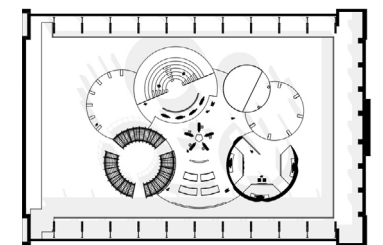

NOTES
DRAWINGS FOR
DESIGN INTENT
ONLY

DRAWING
CONTENT GRAPHICS
CONT'D

SCALE
3/8"=1'

DATE
DEC.06.2023

DRAWING NO
EX4.20

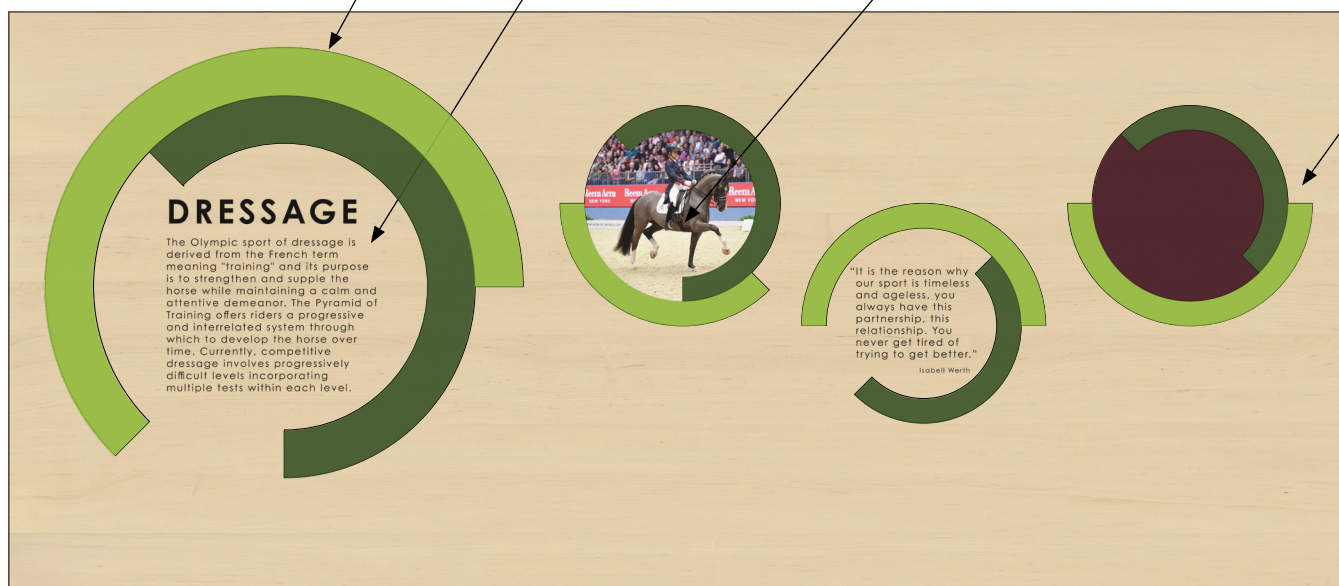
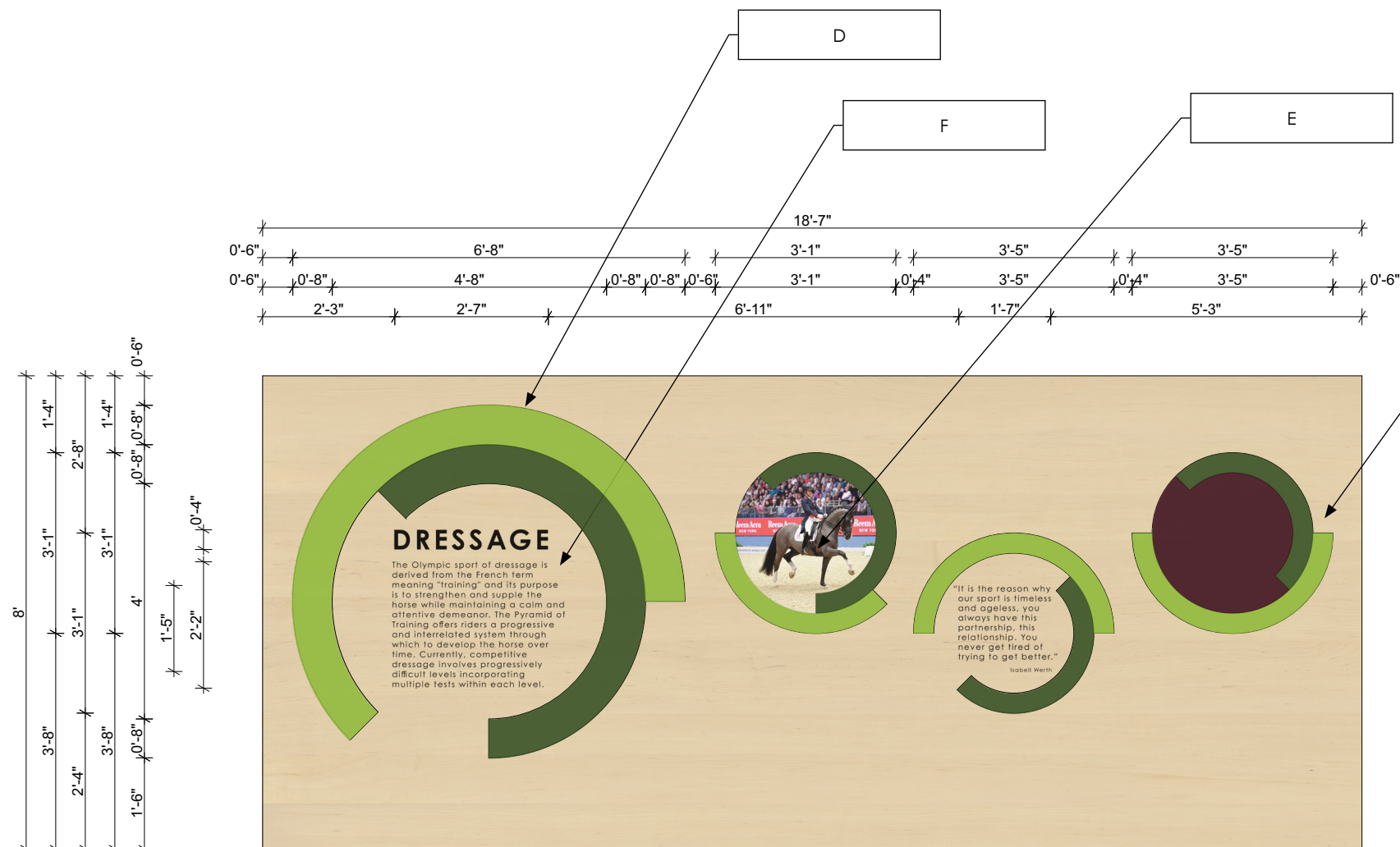

1 **FRONT VIEW** 04B.03.GR01-08
scale: 3/8"=1'

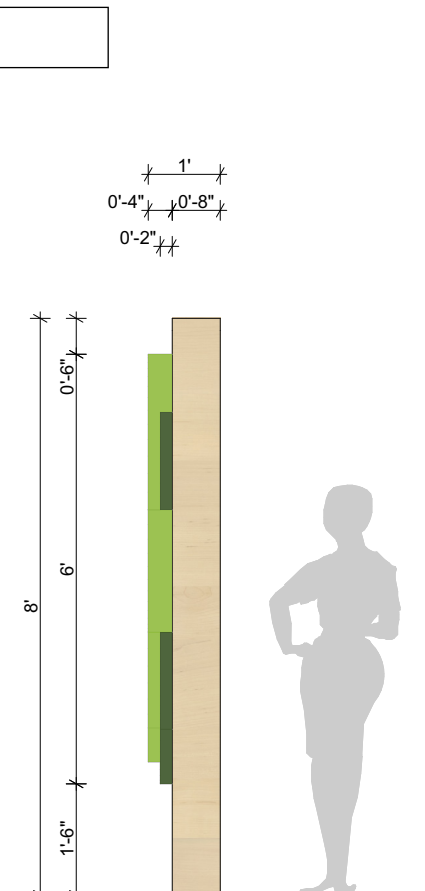

1 **SIDE VIEW** 04B.03.GR01-08
scale: 3/8"=1'

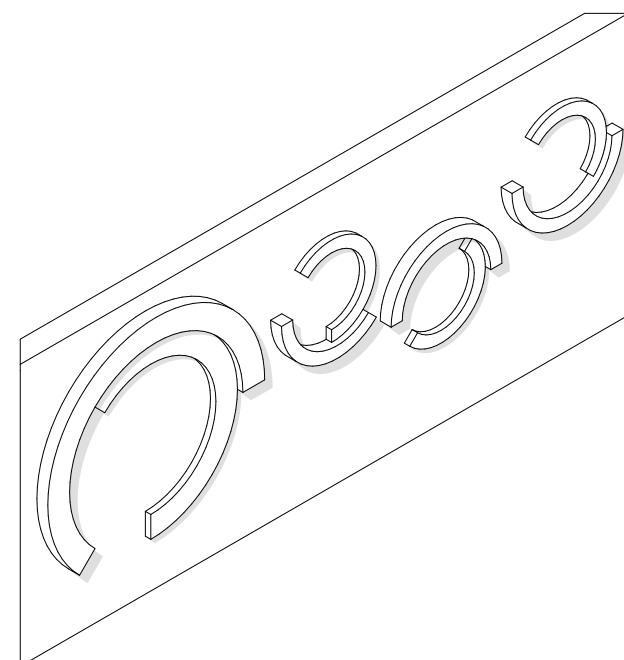

1 **AXONOMETRIC** 04B.03.GR01-08
scale: 3/8"=1'



PROJECT
HORSECENTRISM
THESIS CAPSTONE
EXHIBIT

DRAWN BY
FLAVIA PEDROSA TONIETTO

SITE
**PARK AVENUE ARMORY
NEW YORK**

CLIENTS



KEY PLAN

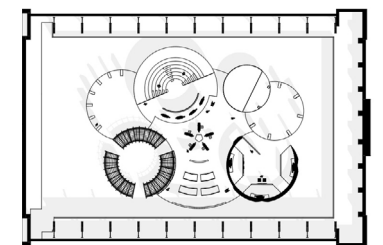

NOTES
DRAWINGS FOR
DESIGN INTENT
ONLY

DRAWING
CONTENT GRAPHICS
CONT'D

SCALE
3/8"=1'

DATE
DEC.06.2023

DRAWING NO
EX4.21

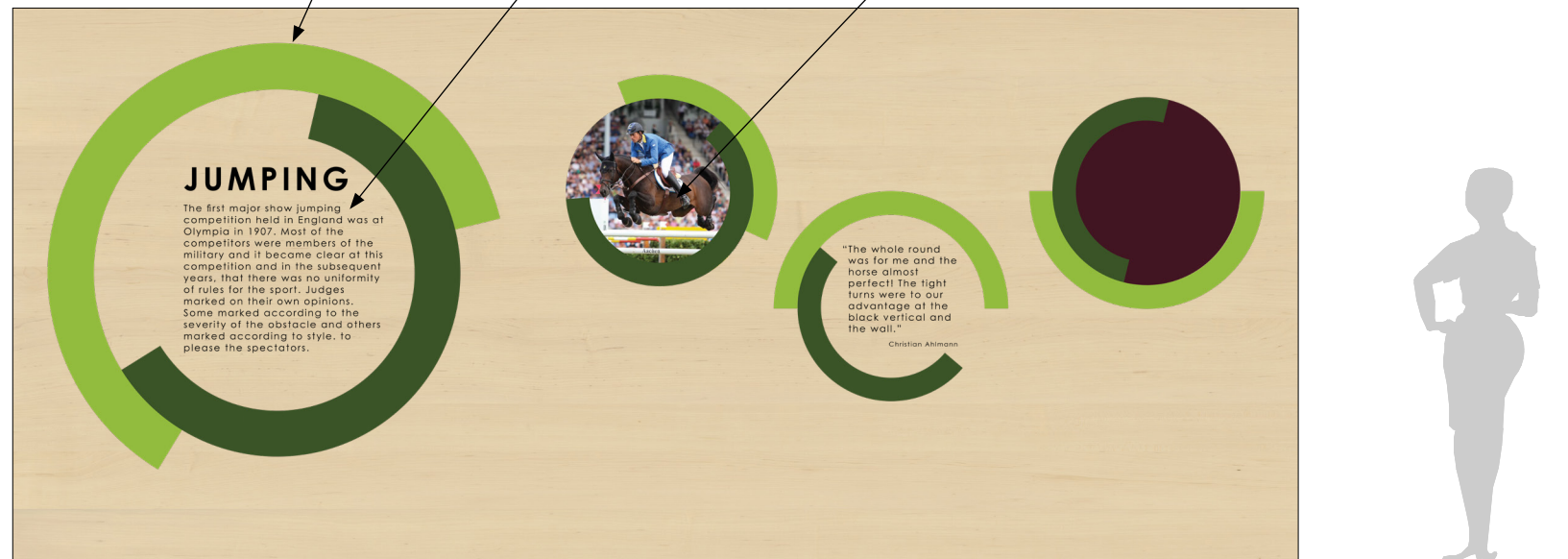
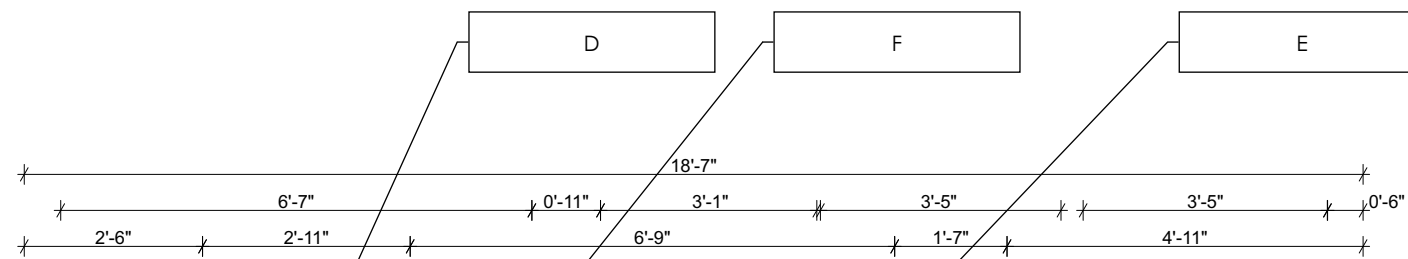

1 FRONT VIEW 04B.04.GR01-08
scale: 3/8"=1'

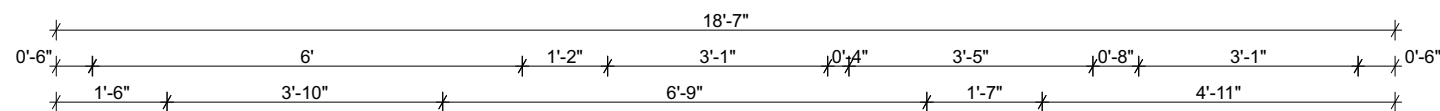

1 FRONT VIEW 04B.05.GR01-08
scale: 3/8"=1'

DETAILS



PROJECT
HORSECENTRISM
THESIS CAPSTONE
EXHIBIT

DRAWN BY
FLAVIA PEDROSA TONIETTO

SITE
**PARK AVENUE ARMORY
NEW YORK**



KEY PLAN

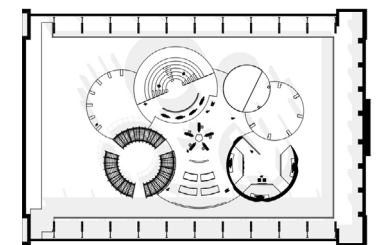

NOTES
DRAWINGS FOR
DESIGN INTENT
ONLY

DRAWING
**04B EXTERNAL WALL
FLOOR PLAN**

SCALE
1/8"=1'

DATE
DEC.06.2023

DRAWING NO
EX5.01

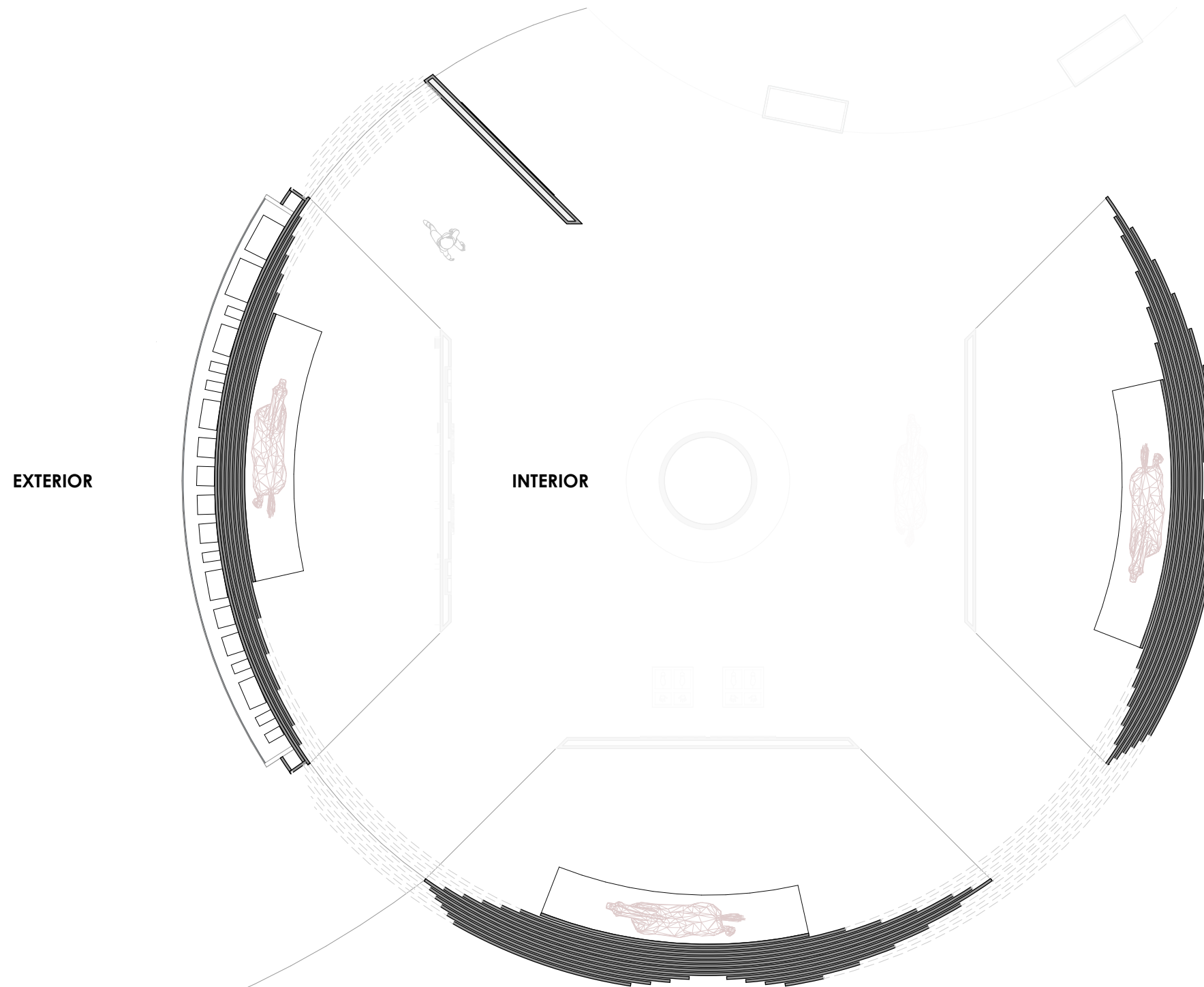

1 **04B EXTERNAL WALL FLOOR PLAN**
scale: 1/8"=1'



PROJECT
HORSECENTRISM
THESIS CAPSTONE
EXHIBIT

DRAWN BY
FLAVIA PEDROSA TONIETTO

SITE
**PARK AVENUE ARMORY
NEW YORK**



KEY PLAN

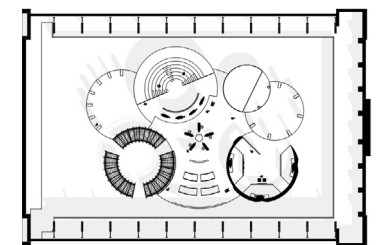

NOTES
DRAWINGS FOR
DESIGN INTENT
ONLY

DRAWING
**04B EXTERNAL WALL
UNFOLDED ELEVATIONS**

SCALE
AS NOTED

DATE
DEC.06.2023

DRAWING NO
EX5.02

EXCERPT A

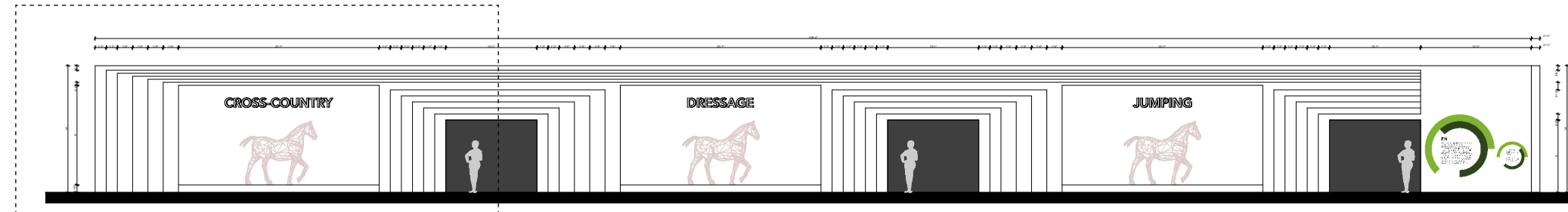

1 **04B INTERIOR UNFOLDED WALL ELEVATION**
scale: 1/16"=1'

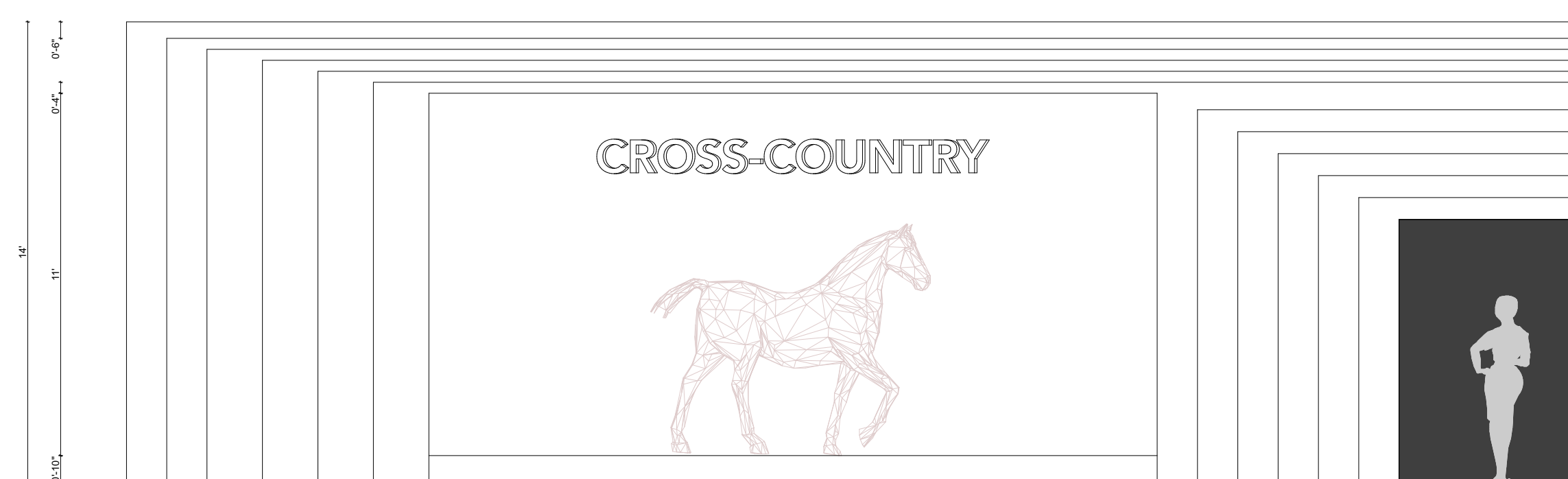

1 **EXCERPT A**
scale: 1/4"=1'



PROJECT
HORSECENTRISM
THESIS CAPSTONE
EXHIBIT

DRAWN BY
FLAVIA PEDROSA TONIETTO

SITE
**PARK AVENUE ARMORY
NEW YORK**



KEY PLAN

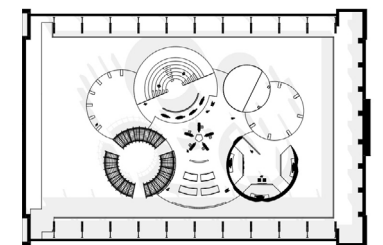

NOTES
DRAWINGS FOR
DESIGN INTENT
ONLY

DRAWING
**04B EXTERNAL WALL
UNFOLDED ELEVATIONS**

SCALE
AS NOTED

DRAWING NO
EX5.03

DATE
DEC.06.2023

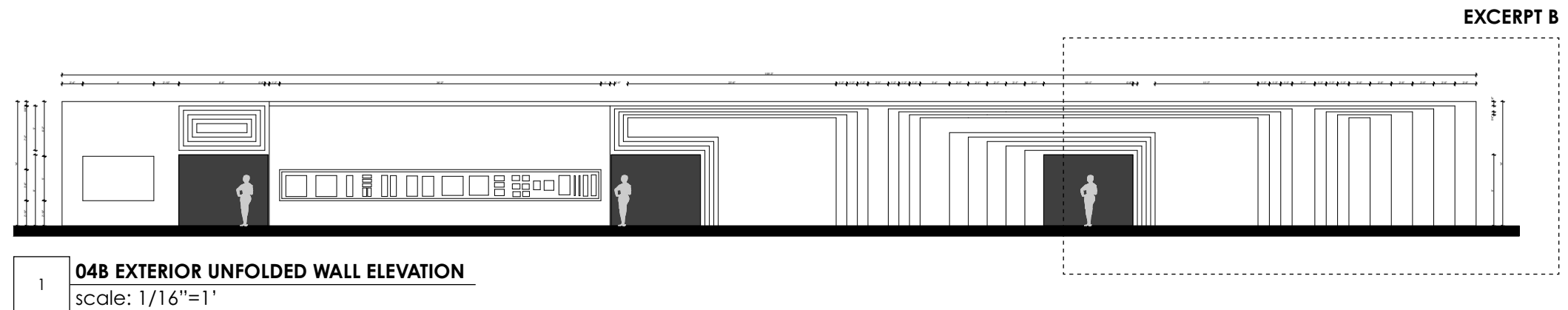

1 **04B EXTERIOR UNFOLDED WALL ELEVATION**
scale: 1/16"=1'

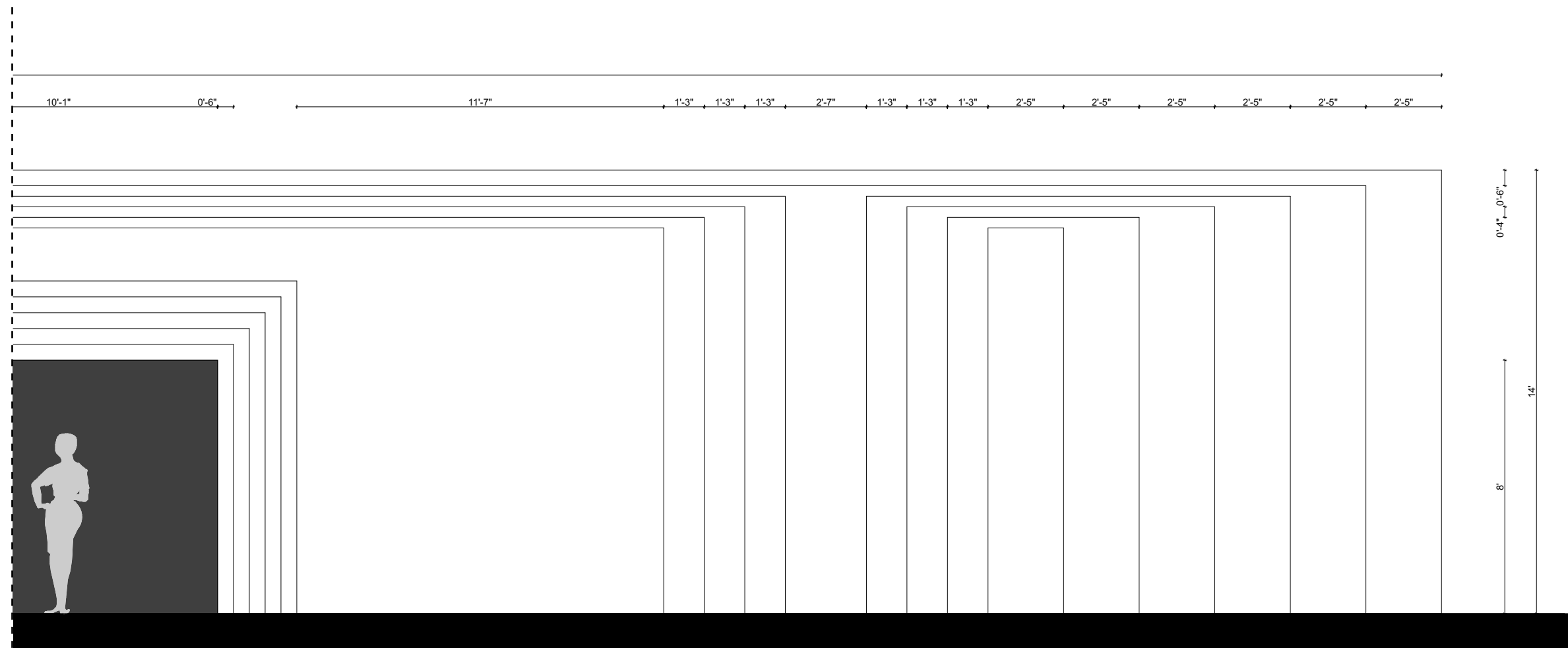

1 **EXCERPT B**
scale: 1/4"=1'



PROJECT
HORSECENTRISM
THESIS CAPSTONE
EXHIBIT

DRAWN BY
FLAVIA PEDROSA TONIETTO

SITE
**PARK AVENUE ARMORY
NEW YORK**



KEY PLAN

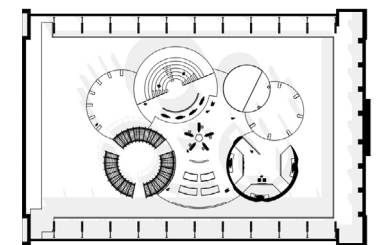

NOTES
DRAWINGS FOR
DESIGN INTENT
ONLY

DRAWING
**04B FLOOR PLAN
EXTERNAL WALL**

SCALE
1/8"=1'

DATE
DEC.06.2023

DRAWING NO
EX5.04

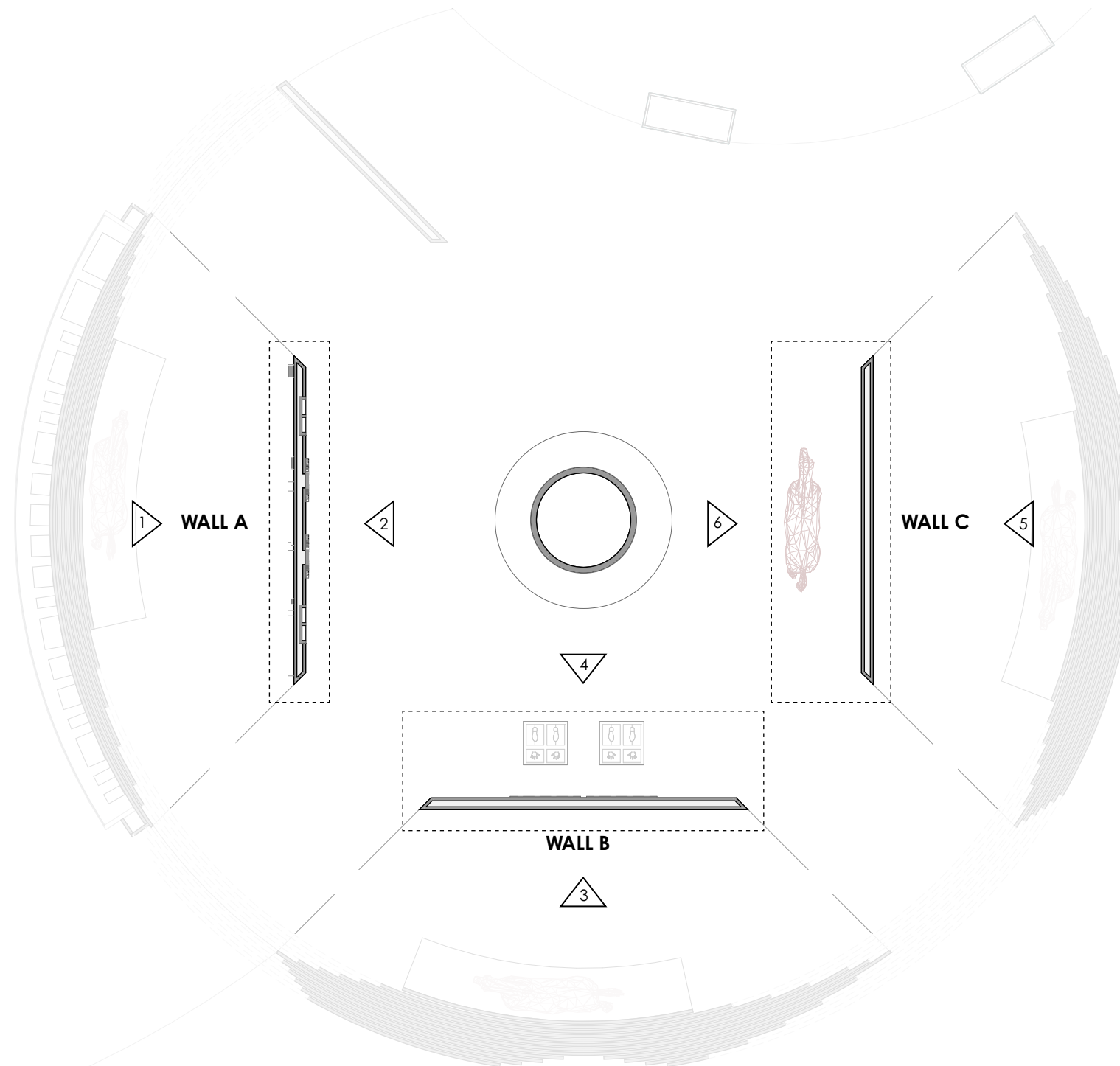

1 **04B CENTRAL WALLS FLOOR PLAN**
scale: 1/8"=1'



PROJECT
HORSECENTRISM
THESIS CAPSTONE
EXHIBIT

DRAWN BY
FLAVIA PEDROSA TONIETTO

SITE
**PARK AVENUE ARMORY
NEW YORK**

CLIENTS



KEY PLAN

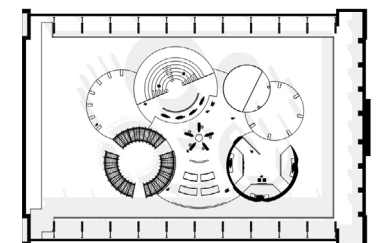

NOTES
DRAWINGS FOR
DESIGN INTENT
ONLY

DRAWING
**04B FLOOR PLAN
CENTRAL WALL A**

SCALE
1/4"=1'

DATE
DEC.06.2023

DRAWING NO
EX5.05

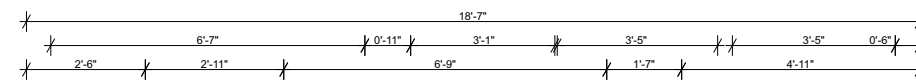

04B ELEVATION 1
scale: 1/4"=1'

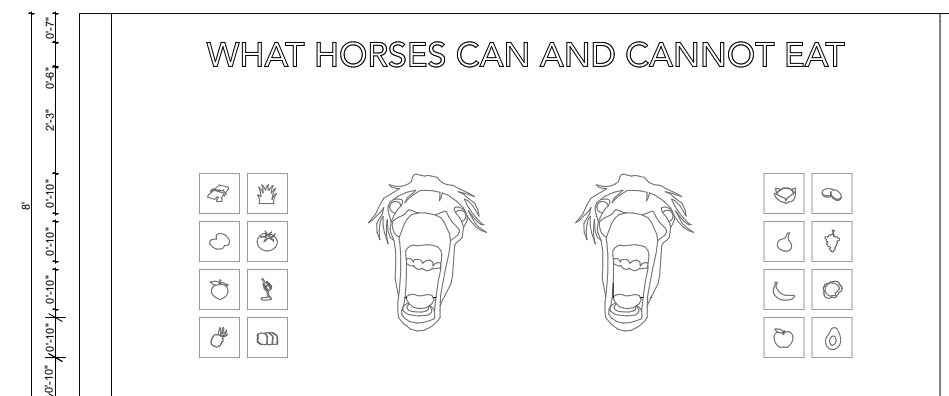
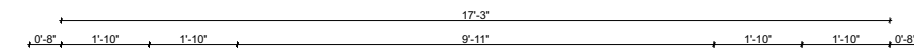

04B ELEVATION 2
scale: 1/4"=1'

SECTION 1

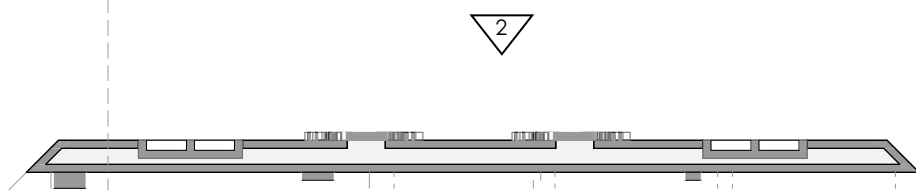

04B WALL A FLOOR PLAN
scale: 1/4"=1'

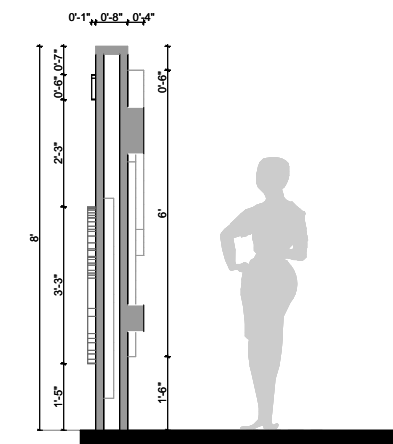

04B SECTION 1
scale: 1/4"=1'



PROJECT
HORSECENTRISM
THESIS CAPSTONE
EXHIBIT

DRAWN BY
FLAVIA PEDROSA TONIETTO

SITE
**PARK AVENUE ARMORY
NEW YORK**

CLIENTS



KEY PLAN

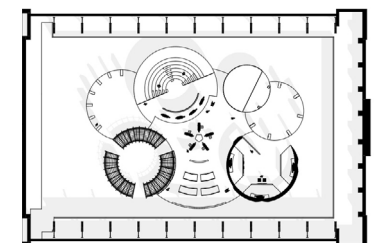

NOTES
DRAWINGS FOR
DESIGN INTENT
ONLY

DRAWING
**04B FLOOR PLAN
CENTRAL WALL B**

SCALE
1/4"=1'

DATE
DEC.06.2023

DRAWING NO
EX5.06

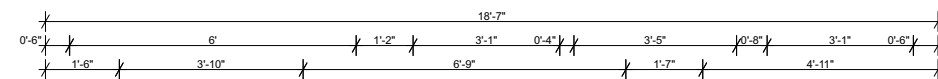

1 **04B ELEVATION 3**
scale: 1/4"=1'

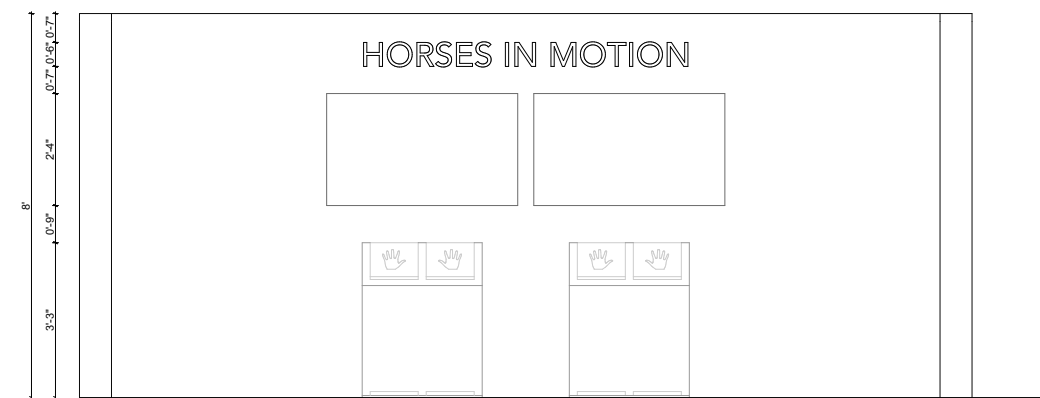
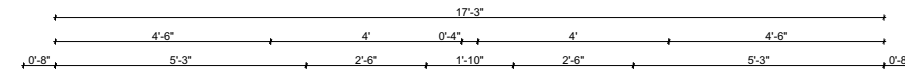

1 **04B ELEVATION 4**
scale: 1/4"=1'

SECTION 2

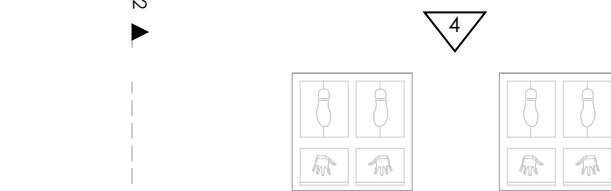

1 **04B WALL B FLOOR PLAN**
scale: 1/4"=1'

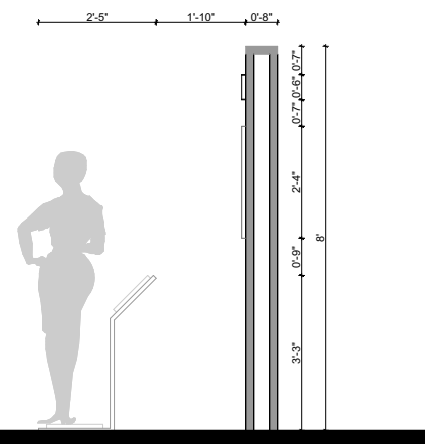

1 **04B SECTION 2**
scale: 1/4"=1'



PROJECT
HORSECENTRISM
THESIS CAPSTONE EXHIBIT

DRAWN BY
FLAVIA PEDROSA TONIETTO

SITE
**PARK AVENUE ARMORY
NEW YORK**

CLIENTS



KEY PLAN

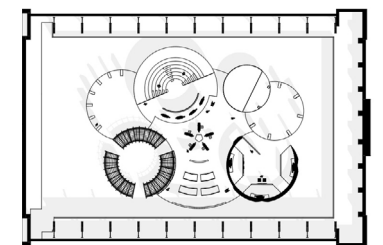

NOTES
DRAWINGS FOR
DESIGN INTENT
ONLY

DRAWING
**04B FLOOR PLAN
CENTRAL WALL C**

SCALE
1/4"=1'

DATE
DEC.06.2023

DRAWING NO
EX5.07

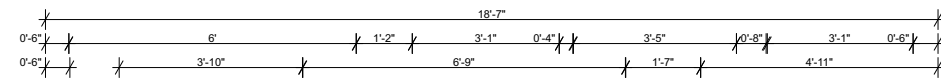

1 **04B ELEVATION 5**
scale: 1/4"=1'

GROOMING THE HORSE

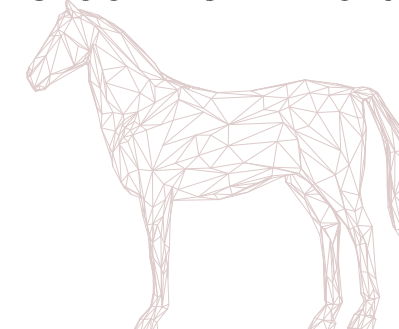

1 **04B ELEVATION 6**
scale: 1/4"=1'

SECTION 3

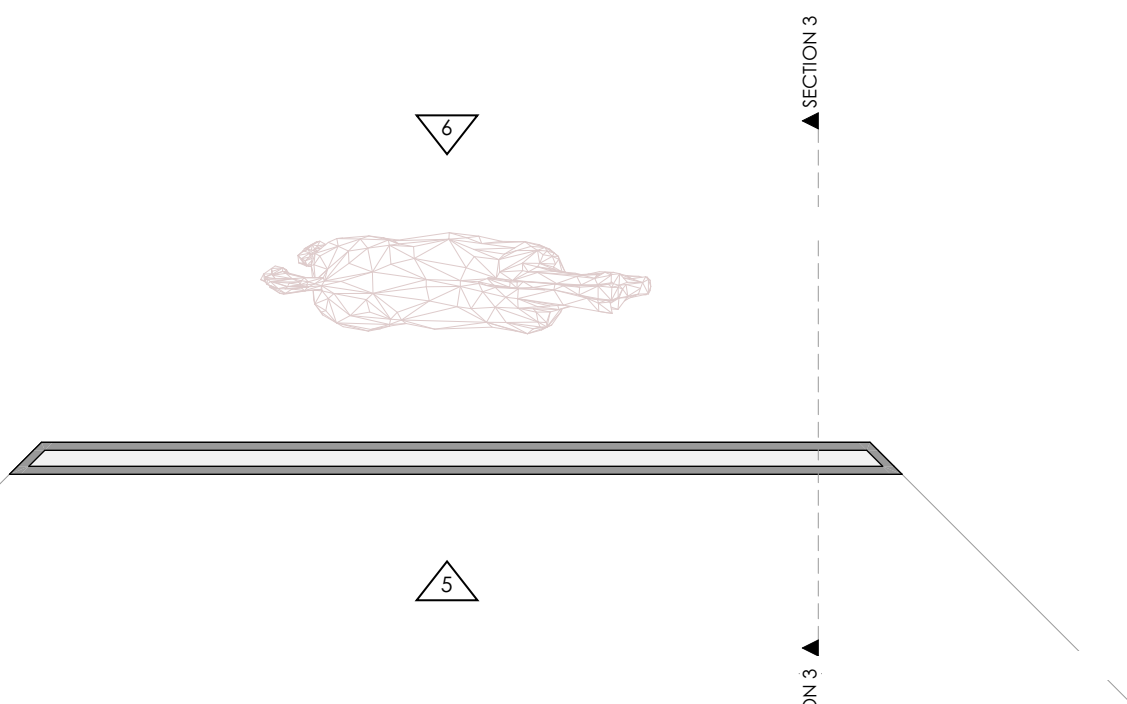

1 **04B WALL C FLOOR PLAN**
scale: 1/4"=1'

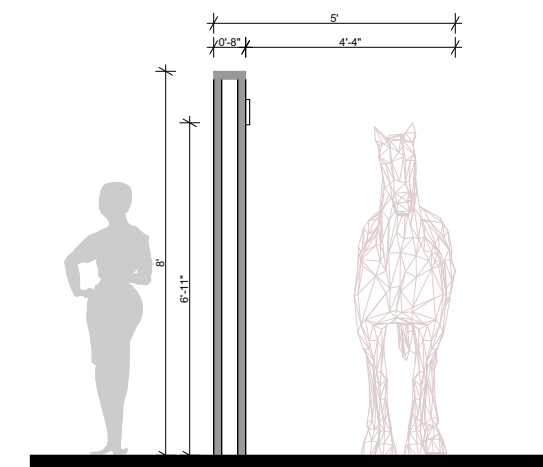

1 **04B SECTION 3**
scale: 1/4"=1'



1 04B THE EQUESTRIAN WORLD AXONOMETRIC



PROJECT
HORSECENTRISM
THESIS CAPSTONE
EXHIBIT

DRAWN BY
FLAVIA PEDROSA TONIETTO

SITE
**PARK AVENUE ARMORY
NEW YORK**



KEY PLAN

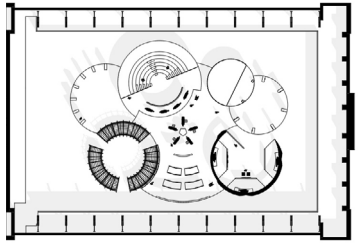

NOTES
DRAWINGS FOR
DESIGN INTENT
ONLY

DRAWING
04B AXONOMETRIC

SCALE
NTS

DRAWING NO
EX5.08

DATE
DEC.06.2023

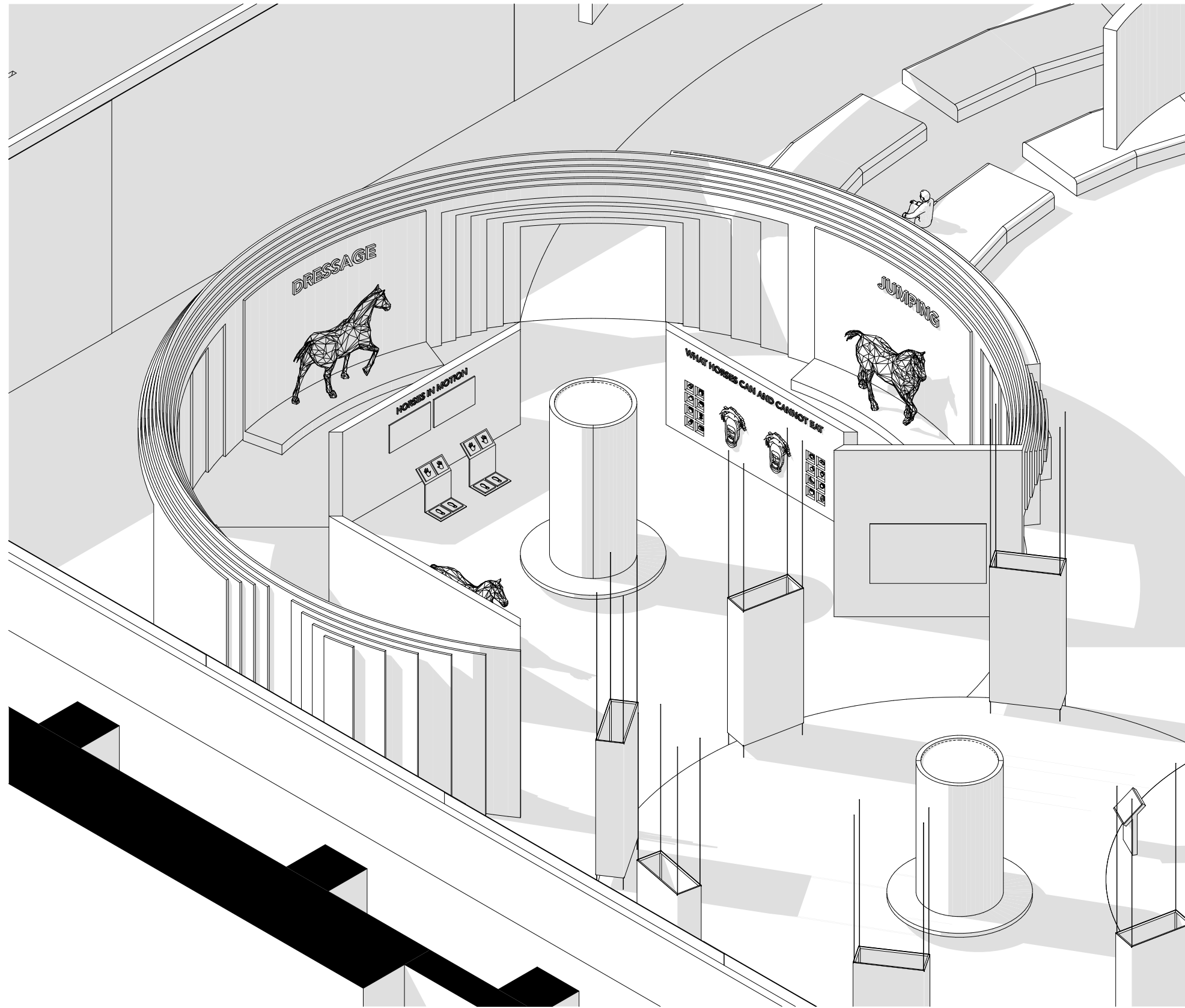

1 04B THE EQUESTRIAN WORLD AXONOMETRIC



PROJECT
HORSECENTRISM
THESIS CAPSTONE
EXHIBIT

DRAWN BY
FLAVIA PEDROSA TONIETTO

SITE
**PARK AVENUE ARMORY
NEW YORK**



KEY PLAN

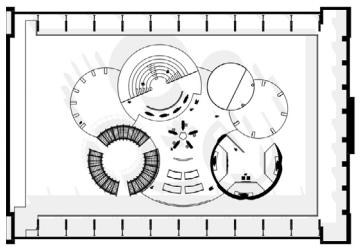

NOTES
DRAWINGS FOR
DESIGN INTENT
ONLY

DRAWING
04B AXONOMETRIC

SCALE
NTS

DRAWING NO
EX5.09

DATE
DEC.06.2023

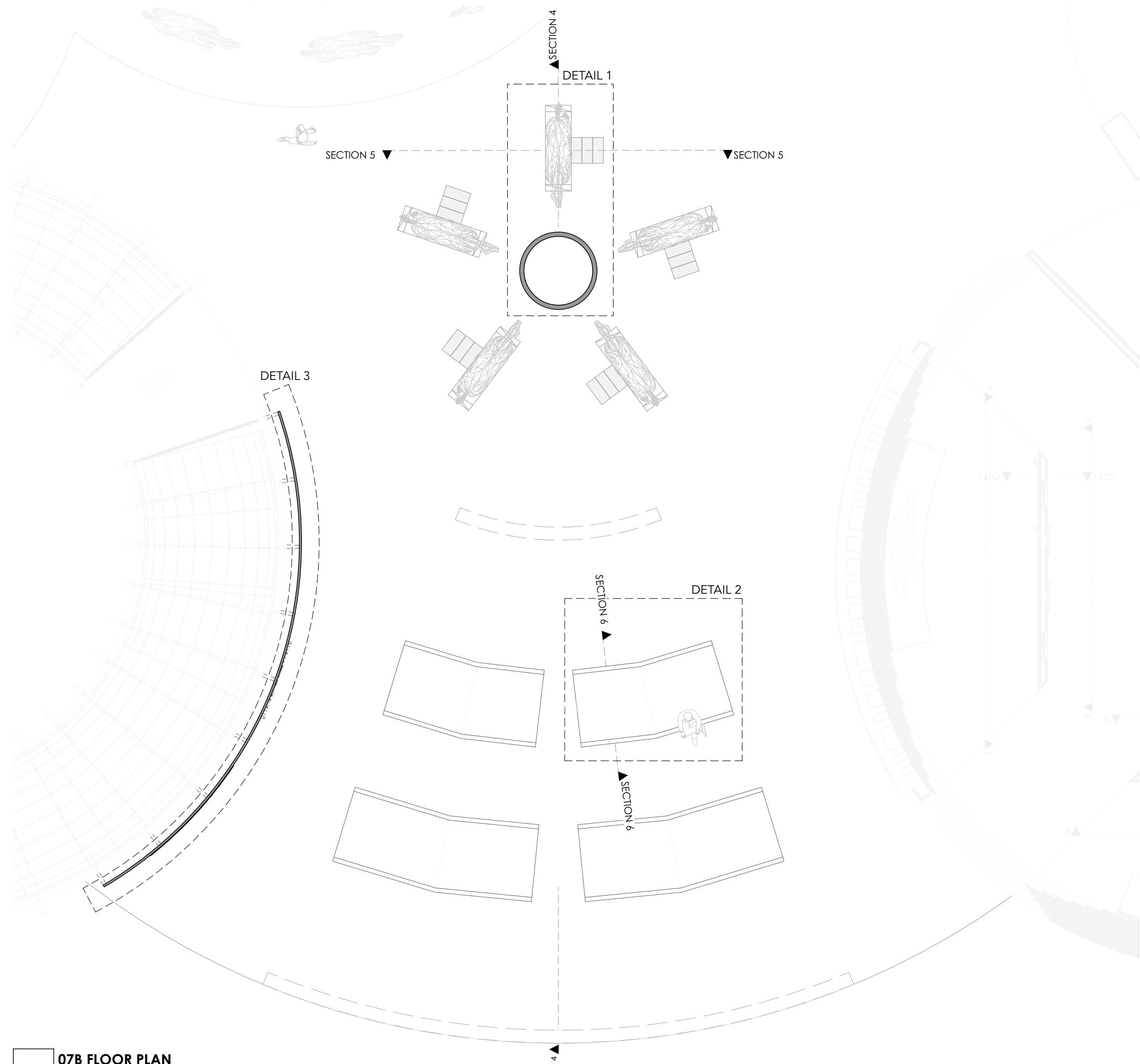

1 **07B FLOOR PLAN**
scale: 1/8"=1'



PROJECT
HORSECENTRISM
THESIS CAPSTONE EXHIBIT

DRAWN BY
FLAVIA PEDROSA TONIETTO

SITE
**PARK AVENUE ARMORY
NEW YORK**



KEY PLAN

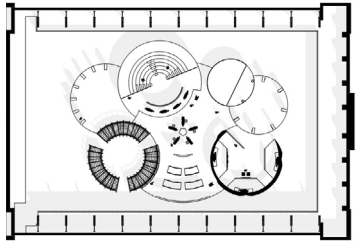

NOTES
DRAWINGS FOR DESIGN INTENT ONLY

DRAWING
07B FLOOR PLAN

SCALE
1/8"=1'

DATE
DEC.06.2023

DRAWING NO
EX5.10



PROJECT
HORSECENTRISM
THESIS CAPSTONE
EXHIBIT

DRAWN BY
FLAVIA PEDROSA TONIETTO

SITE
**PARK AVENUE ARMORY
NEW YORK**



KEY PLAN

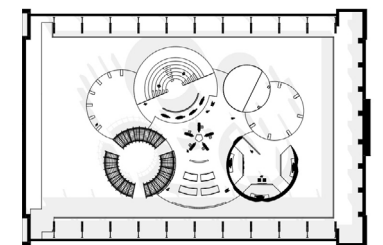

NOTES
DRAWINGS FOR
DESIGN INTENT
ONLY

DRAWING
DETAIL 1

SCALE
AS NOTED

DATE
DEC.06.2023

DRAWING NO
EX5.11

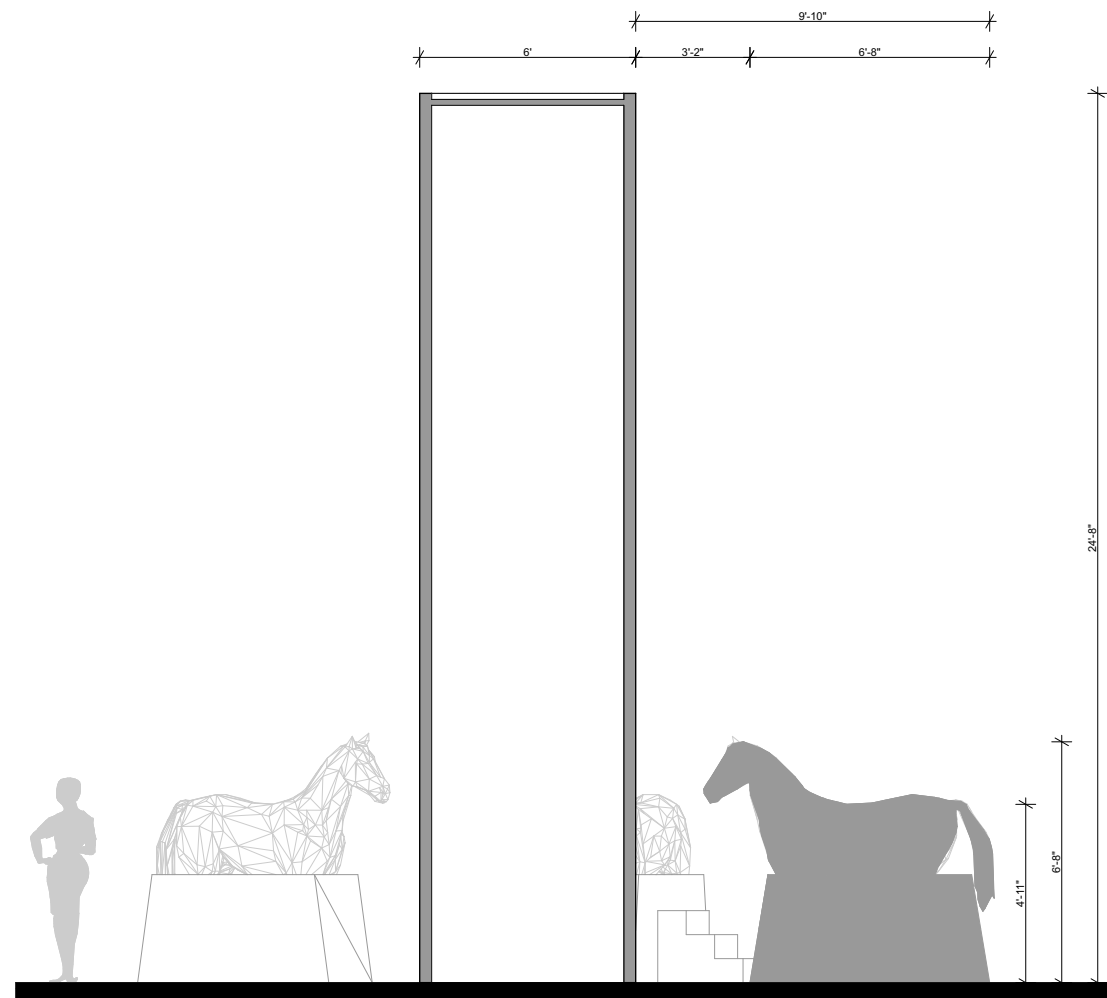

1 SECTION 4 - LONGITUDINAL
scale: 3/16"=1'

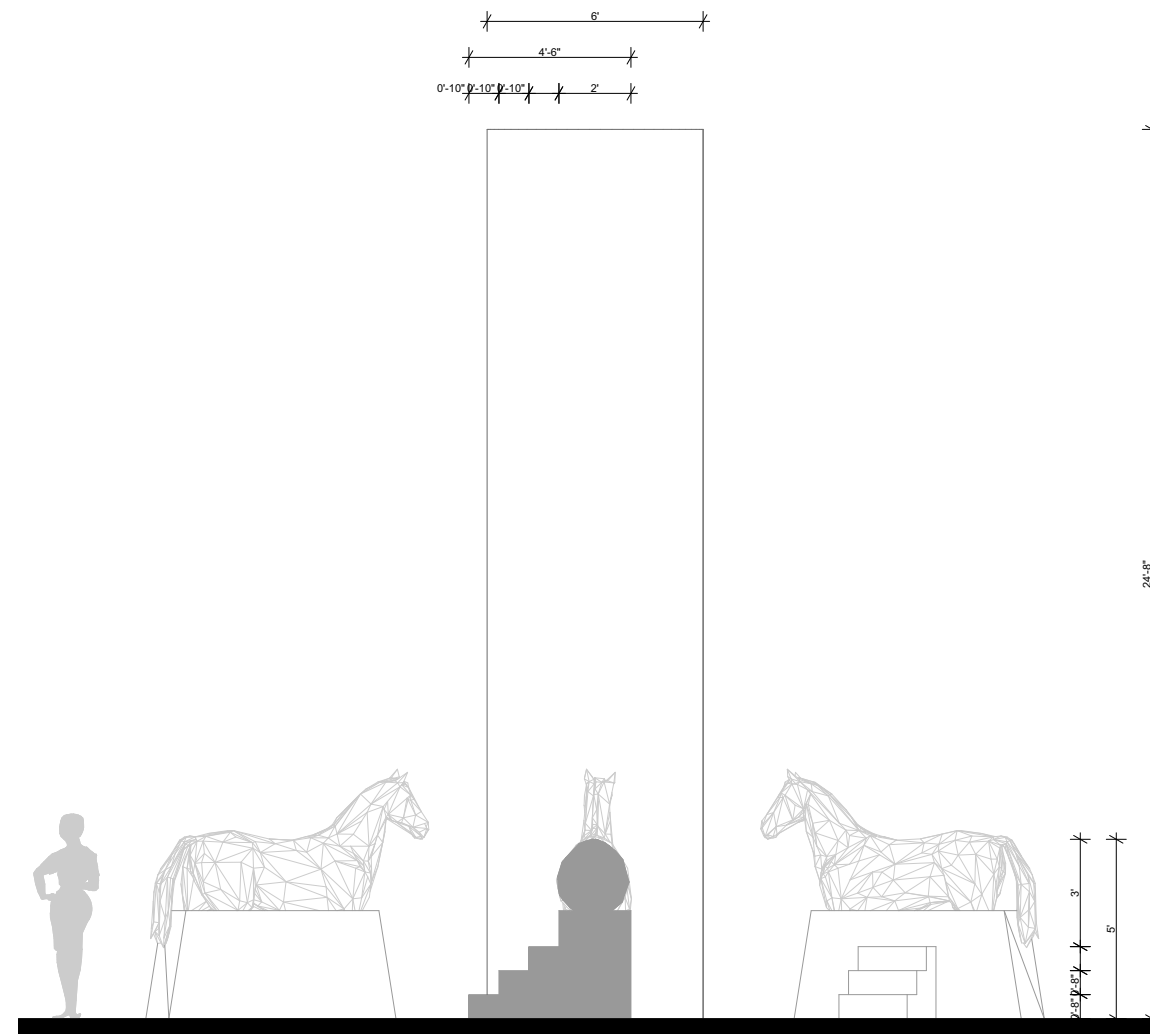

1 SECTION 5 - TRANSVERSAL
scale: 3/16"=1'

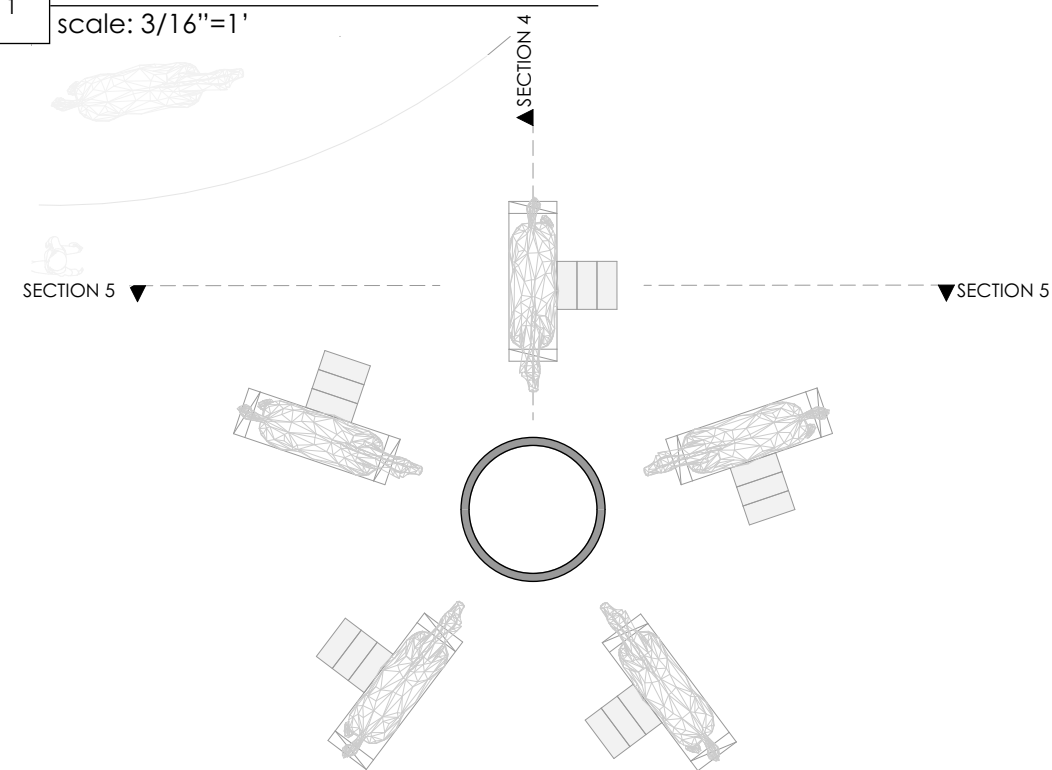

1 07B HORSE SIMULATOR FLOOR PLAN
scale: 1/8"=1'

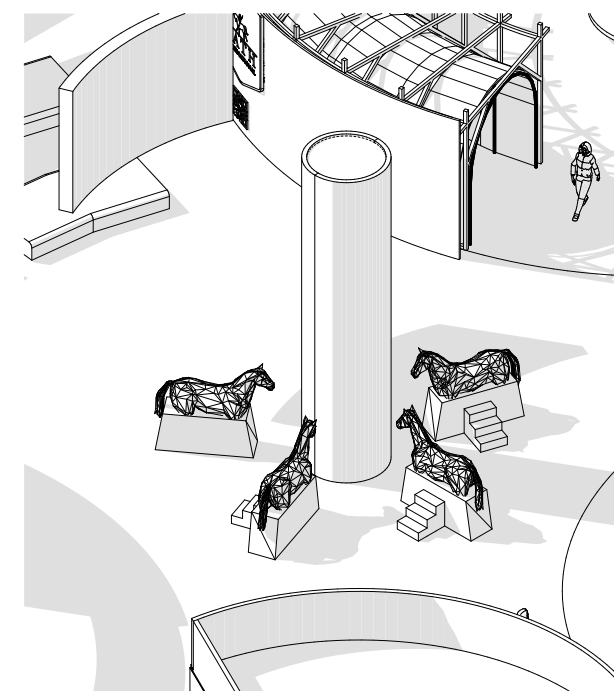

1 07B HORSE SIMULATOR AXONOMETRIC



PROJECT
HORSECENTRISM
THESIS CAPSTONE
EXHIBIT

DRAWN BY
FLAVIA PEDROSA TONIETTO

SITE
**PARK AVENUE ARMORY
NEW YORK**

CLIENTS



KEY PLAN

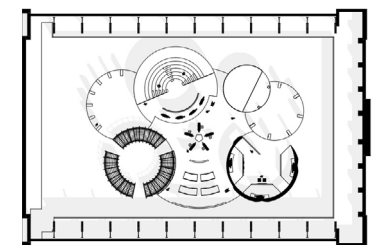

NOTES
DRAWINGS FOR
DESIGN INTENT
ONLY

DRAWING
DETAIL 3

SCALE
1/4"=1'

DATE
DEC.06.2023

DRAWING NO
EX5.13

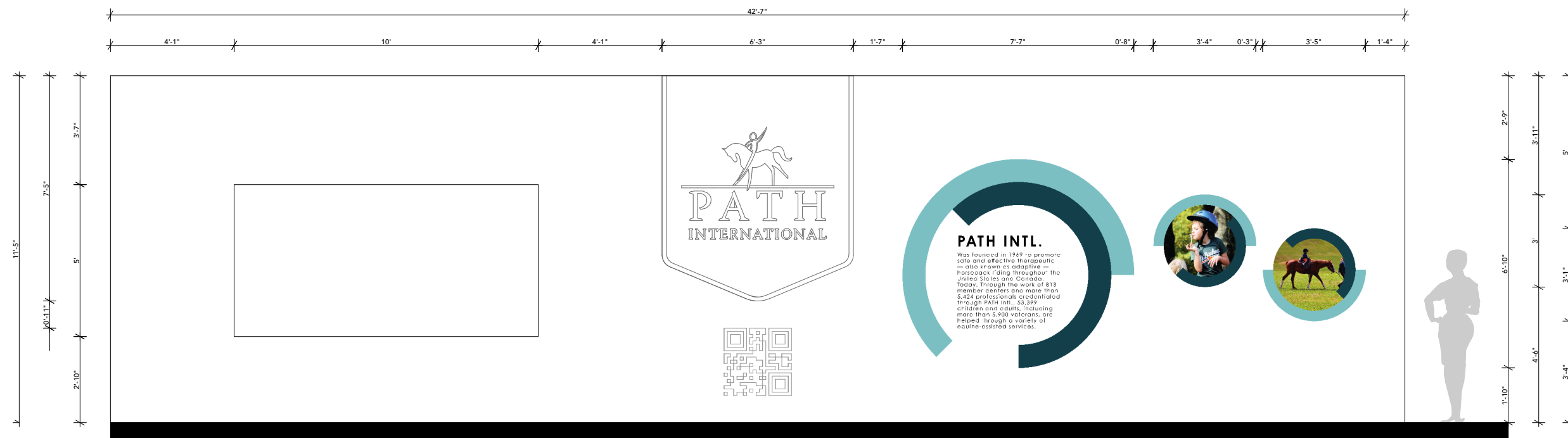

1 **DETAIL 3 - UNFOLDED WALL**
scale: 1/4"=1'



A mutually beneficial relationship between humans and horses.

DESIGN DEVELOPMENT PACKAGE

GRADUATE THESIS

MA EXHIBITION AND EXPERIENCE DESIGN
SUNY FASHION INSTITUTE OF TECHNOLOGY

FLAVIA PEDROSA TONIETTO