

LEGGENDE
DELLA
PIETRA

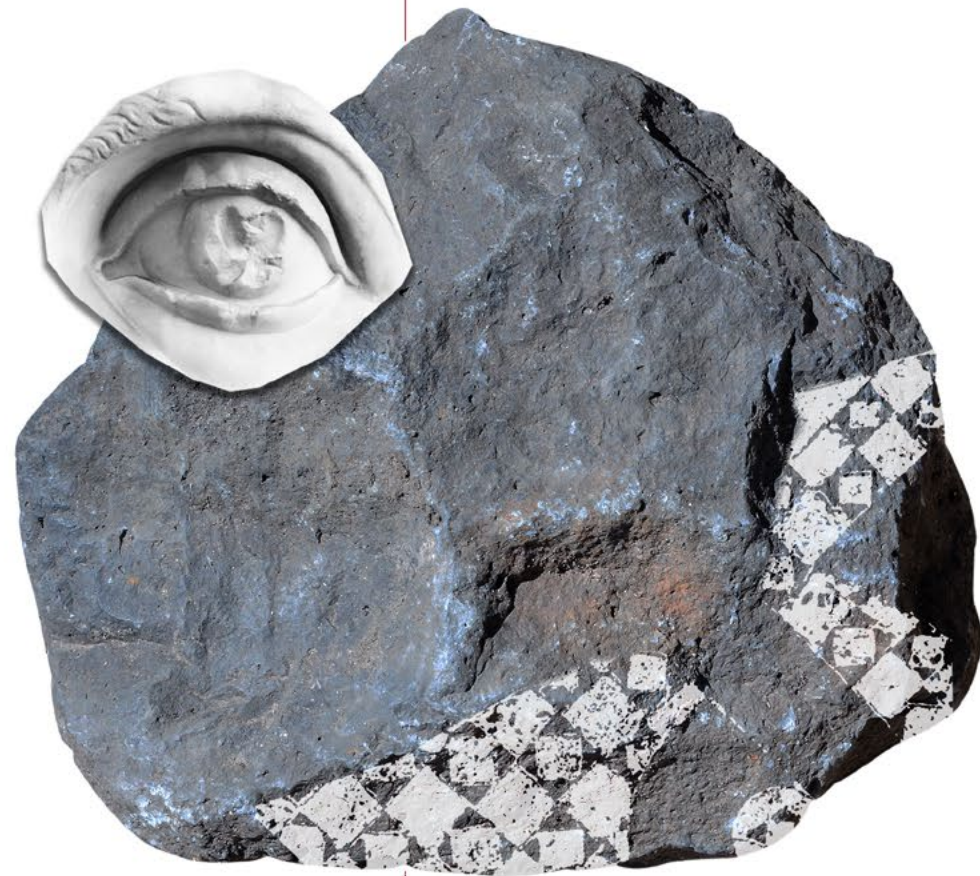

DESIGN DEVELOPMENT DECK
ROBERT REULAND JR.

DECEMBER 9, 2024
FASHION INSTITUTE OF TECHNOLOGY

DOCUMENT USAGE

These drawings were made to fulfill partial requirements for the Thesis Capstone of the FIT Masters Program in the Exhibition and Experience Design by Robert Charles Reuland Jr.

EXHIBIT SUMMARY

- EX.01.01 BIG IDEA
- EX.01.02 THESIS STATEMENT
- EX.01.03 CLIENT
- EX.01.04 GOALS
- EX.01.05 AUDIENCE
- EX.01.06 CONCEPT BUBBLE DIAGRAM
- EX.01.07 VENUE
- EX.01.08 PRE VISIT
- EX.01.09 PRE VISIT ARRIVAL
- EX.01.10 MANAGEMENT
- EX.01.11 SITE BIRD'S EYE VIEW
- EX.01.12-21 SIMPLIFIED PLAN

PLANS & SCHEDULES

- EX.02.01 GRAPHIC SCHEDULE
- EX.02.02 MATERIAL SCHEDULE
- EX.02.03 LIGHTING SCHEDULE
- EX.02.04 OBJECT LIST
- EX.02.05 MEDIA SCHEDULE
- EX.02.06 GENERAL PLAN
- EX.02.07 DIMENSIONAL PLAN
- EX.02.08 MATERIAL PLAN
- EX.02.09 MEDIA PLAN
- EX.02.10 GRAPHIC LOCATION PLAN
- EX.02.11 LIGHTING PLAN
- EX.02.12 POWER DATA PLAN
- EX.02.13 SECTION 01
- EX.02.14 SECTION 02
- EX.02.15 AXONOMETRIC

GRAPHICS

- EX.03.01 GRAPHIC LOOK + FEEL
- EX.03.02 LOGO
- EX.03.03 COLORS
- EX.03.04 TYPOGRAPHY
- EX.03.05 GRAPHIC COLLATERAL
- EX.03.06 OOH CAMPAIGN
- EX.03.07 ELEVATION ENTRANCE
- EX.03.08 ELEVATION INTRO AREA
- EX.03.09 *DETAIL
- EX.03.10 EXHIBIT AREA SIGNAGE
- EX.03.11 *DETAIL
- EX.03.12 *DETAIL
- EX.03.13 ELEVATION MURAL
- EX.03.14 ELEVATION OUTDOOR
- EX.03.15 ELEVATION WAY FINDING

EXHIBITION DETAILING

- EX.04.01 MODULAR STRUCTURE 01A
- EX.04.02 MODULAR STRUCTURE 02A
- EX.04.03 MODULAR STRUCTURE 03A
- EX.04.04 MODULAR STRUCTURE 05A
- EX.04.05 OUTDOOR DISPLAY

LEGGENDE
DELLA
PIETRA

SITE

The Ruins of Santa Maria del Piano
02030 Pozzaglia Sabino RI, Italy

CLIENT

The Italian Ministry of Culture
Via del Collegio Romano 27, in central Rome)

KEY PLAN

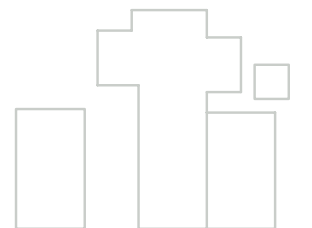

DRAFTED BY Robert Reuland
DATE Dec 9, 2024
SCALE N/A

ITINERARY

DRAWING NUMBER
EX.00.01

A photograph of an ancient stone structure, possibly a tomb or a small chamber. The walls are made of rough-hewn, light-colored stone blocks. The floor is also made of stone, with some areas appearing to be paved with larger, smoother stones. In the background, a wooden structure with a prominent X-shaped beam is visible, suggesting a roof or a partition. The lighting is somewhat dim, creating a sense of depth and mystery. The text "EXHIBIT SUMMARY" is overlaid in the center of the image in a white, serif font.

EXHIBIT SUMMARY

BIG IDEA

The Ruins of Santa Maria del Piano serve as **powerful connectors between Italy's storied past and dynamic present**. By engaging with these evocative spaces, visitors confront questions of cultural identity, community, and the dynamic of the disappearance and persistence of cultural icons. The exhibition will connect locals and tourists by encouraging them to compare symbols, traditions, language, and biases related to the region and site.

**ROBERT
CHARLES
REULAND JR.**

DOCUMENT USAGE

These drawings were made to fulfill partial requirements for the Thesis Capstone of the FIT Masters Program in the Exhibition and Experience Design by Robert Charles Reuland Jr.

LEGGENDE
DELLA
PIETRA

SITE

The Ruins of Santa Maria del Piano
02030 Pozzaglia Sabino RI, Italy

CLIENT

The Italian Ministry of Culture
(Via del Collegio Romano 27, in central Rome)

KEY PLAN



DRAFTED BY	Robert Reuland
DATE	Dec 9, 2024
SCALE	N/A

BIG IDEA

DRAWING NUMBER
EX.01.01

THESIS
STATEMENT

Authenticity defined as that which is natural, respects local contexts, and is rooted in tradition and history, is something humans crave in their everyday experiences. Ruins more than other historic sites are physical manifestations of authenticity and act as anchors for those seeking a sense of connection to culture and self-identity. Historical ruins are magical places and monuments of memory that link us to tradition. Creating innovative exhibitions that are layered on ancient ruins or historic sites can bridge the gap, connecting audiences to history, local culture, and ultimately their personal growth. Authentic experiences are those that consider the site and therefore connect audiences deeply to local culture. In countries like Italy filled with abandoned ruins these spaces provide wonderful opportunities for fostering authenticity in exhibitions and for promoting reuse. Authentic sites like ruins can make exhibitions highly relevant for local and foreign audiences alike.

ROBERT
CHARLES
REULAND JR.

DOCUMENT USAGE

These drawings were made to fulfill partial requirements for the Thesis Capstone of the FIT Masters Program in the Exhibition and Experience Design by Robert Charles Reuland Jr.

LEGGENDE
DELLA
PIETRA

SITE

The Ruins of Santa Maria del Piano
02030 Pozzaglia Sabino RI, Italy

CLIENT

The Italian Ministry of Culture
Via del Collegio Romano 27, in central Rome)

KEY PLAN

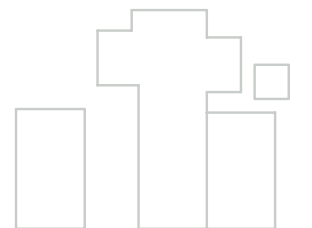

DRAFTED BY	Robert Reuland
DATE	Dec 9, 2024
SCALE	N/A

BIG IDEA

DRAWING NUMBER
EX.01.02

CLIENT



‘The Italian Ministry of Culture’s mission is to protect and enhance the cultural heritage and to promote cultural activities related to landscape, entertainment, cinema and audiovisual. The protection and enhancement of cultural heritage are aimed at preserving the memory of communities and territories, promoting the development of culture and knowledge of **tangible** and **intangible heritage**.’

**ROBERT
CHARLES
REULAND JR.**

DOCUMENT USAGE

These drawings were made to fulfill partial requirements for the Thesis Capstone of the FIT Masters Program in the Exhibition and Experience Design by Robert Charles Reuland Jr.

LEGGENDE
DELLA
PIETRA

SITE

The Ruins of Santa Maria del Piano
02030 Pozzaglia Sabino RI, Italy

CLIENT

The Italian Ministry of Culture
Via del Collegio Romano 27, in central Rome)

KEY PLAN



DRAFTED BY	Robert Reuland
DATE	Dec 9, 2024
SCALE	N/A

CLIENT

DRAWING NUMBER
EX.01.03

GOALS

PROJECT

- Foster a new form of tourism more akin to the meditative and community-building practices of pilgrimages.
- To imbue with new life the Ruin of Santa Maria del Piano.
- Foster a new sense of the site's significance to the local and tourist community.

EDUCATION

- Build a better understanding of the Abbey's history and the region's local recent history.
- Foster an understanding of the contemporary history and experience of the local people.
- Promote a deeper knowledge of Italian culture and history beyond the predictable.
- Provide an opportunity for exploration of one's own story by experiencing those of others.

EXPERIENCE

- Use storytelling and different media to get audiences to connect to the specific history and place.
- Foster an artistic and experimental interpretation of history.
- Build connection through communal practices (such as hand gestures and symbolic forms).

**ROBERT
CHARLES
REULAND JR.**

DOCUMENT USAGE

These drawings were made to fulfill partial requirements for the Thesis Capstone of the FIT Masters Program in the Exhibition and Experience Design by Robert Charles Reuland Jr.

LEGGENDE
DELLA
PIETRA

SITE

The Ruins of Santa Maria del Piano
02030 Pozzaglia Sabino RI, Italy

CLIENT

The Italian Ministry of Culture
Via del Collegio Romano 27, in central Rome)

KEY PLAN



DRAFTED BY	Robert Reuland
DATE	Dec 9, 2024
SCALE	N/A

GOALS

DRAWING NUMBER

EX.01.04

AUDIENCE

Primary (Youth Seeking Sense of Self)

This exhibition resonates with young audiences, both local and international, who are eager to find deeper connections with culture and history. Through immersive storytelling, myths, and modern interpretations of ancient spaces, it offers them a way to explore universal questions of identity and belonging while engaging with a site that merges the past with the present.



Still from Rossellini's *Voyage to Italy*

Secondary (Older Local Retirees)

For older visitors, particularly those who may feel isolated, the exhibition provides a welcoming space to reconnect with their heritage and share their own experiences. Programs like community storytelling and participatory events encourage interaction, fostering a sense of pride and inclusion while celebrating their vital role in preserving local history.



Still from De Sica's *Umberto D*

ROBERT CHARLES REULAND JR.

DOCUMENT USAGE

These drawings were made to fulfill partial requirements for the Thesis Capstone of the FIT Masters Program in the Exhibition and Experience Design by Robert Charles Reuland Jr.

LEGGENDE
DELLA
PIETRA

SITE

The Ruins of Santa Maria del Piano
02030 Pozzaglia Sabino RI, Italy

CLIENT

The Italian Ministry of Culture
Via del Collegio Romano 27, in central Rome)

KEY PLAN

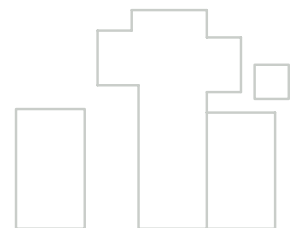

DRAFTED BY	Robert Reuland
DATE	Dec 9, 2024
SCALE	N/A

AUDIENCE

DRAWING NUMBER

EX.01.05

CONCEPT BUBBLE DIAGRAM

TRANSFORMATION

FEAR OF CHANGE

IDENTITY CONFUSION

NATIONAL VS REGIONAL VS GLOBAL

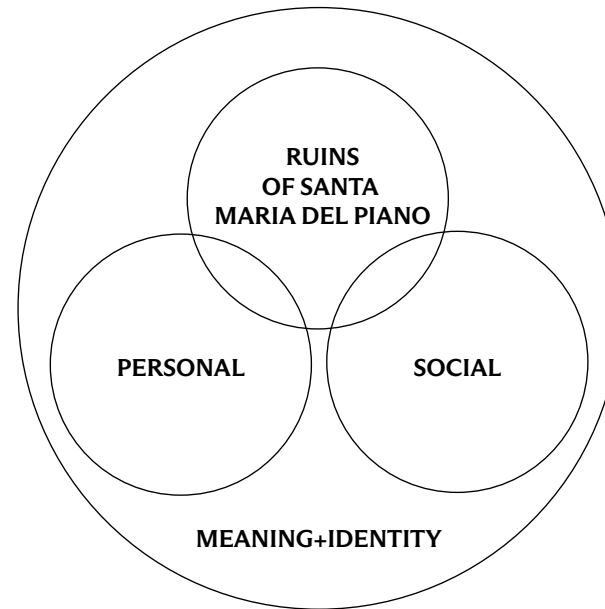

DISCOVERY

MYSTERY & MAGIC OF RUINS

IMAGINATION + CREATIVITY

LEGACY

WEIGHT OF PAST

FEELING INSUFFICIENT PRESENT
DAY SOCIAL STANDARDS

**ROBERT
CHARLES
REULAND JR.**

DOCUMENT USAGE

These drawings were made to fulfill partial requirements for the Thesis Capstone of the FIT Masters Program in the Exhibition and Experience Design by Robert Charles Reuland Jr.

LEGGENDE
DELLA
PIETRA

SITE

The Ruins of Santa Maria del Piano
02030 Pozzaglia Sabino RI, Italy

CLIENT

The Italian Ministry of Culture
Via del Collegio Romano 27, in central Rome)

KEY PLAN



DRAFTED BY Robert Reuland

DATE Dec 9, 2024

SCALE N/A

CONCEPT DIAGRAM

DRAWING NUMBER

EX.01.06

VENUE



The Abbey of Santa Maria del Piano is a magical ruin in the township of Pozzaglia Sabina. Information on the abbey is fairly limited but it is one of the oldest churches in the region of Rieti. There is a dearth of information about its origin. Legend has it that the abbey was built by Charlemagne in 800 AD. With over 1000 years of history there is only so much we can say for sure and much will remain a mystery. In recent years, many of the abbey's ornaments were stolen including its rose window. This ruin, an hour's drive from Rome, could now serve as a point of connection and meditation for local Italians and foreign visitors alike. While this site is difficult to access its clandestine nature could add to its appeal as a hidden gem of archeology and a site of adventure.

**ROBERT
CHARLES
REULAND JR.**

DOCUMENT USAGE

These drawings were made to fulfill partial requirements for the Thesis Capstone of the FIT Masters Program in the Exhibition and Experience Design by Robert Charles Reuland Jr.

LEGGENDE
DELLA
PIETRA

SITE

The Ruins of Santa Maria del Piano
02030 Pozzaglia Sabina RI, Italy

CLIENT

The Italian Ministry of Culture
Via del Collegio Romano 27, in central Rome)

KEY PLAN

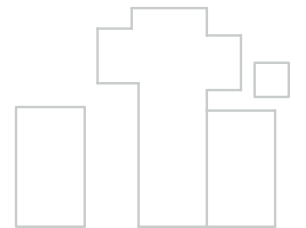

DRAFTED BY	Robert Reuland
DATE	Dec 9, 2024
SCALE	N/A

VENUE

DRAWING NUMBER

EX.01.07

PRE-VISIT

The Leggende Della Pietra campaign combines visual storytelling with cultural nostalgia drawing both tourists and locals to the exhibition. Posters feature collages of stone textures and patterns from the abbey overlaid with evocative writing, evoking the sense of history and mystery. Partnerships with travel platforms like Atlas Obscura target history and architecture enthusiasts, while a programming series, including “Cinema al Aperto,” offers screenings of classic films to appeal to nostalgic audiences and the older local community. This integrated campaign, spanning OOH placements in key locations and digital outreach, creates an emotional and cultural connection to the exhibition while promoting exploration of Santa Maria del Piano’s rich heritage. It also does not reveal too much but keeps the exhibitions a mystery to intrigue audiences.



**ROBERT
CHARLES
REULAND JR.**

DOCUMENT USAGE

These drawings were made to fulfill partial requirements for the Thesis Capstone of the FIT Masters Program in the Exhibition and Experience Design by Robert Charles Reuland Jr.

LEGGENDE
DELLA
PIETRA

SITE

The Ruins of Santa Maria del Piano
02030 Pozzaglia Sabino RI, Italy

CLIENT

The Italian Ministry of Culture
Via del Collegio Romano 27, in central Rome)

KEY PLAN

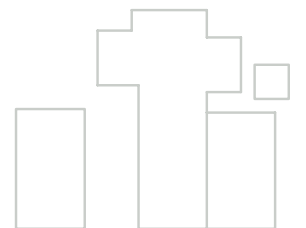

DRAFTED BY Robert Reuland

DATE Dec 9, 2024

SCALE N/A

NAME OF DRAWING

DRAWING NUMBER

EX.01.08

PRE-VISIT - NAVIGATING TO THE SITE

As visitors travel to Santa Maria del Piano, signage along the route marks the way through the rugged terrain, guiding them toward the abbey. For those who prefer an easier approach, a shuttle service is available, offering convenient access while preserving the sense of adventure in reaching this historic site. The journey, framed by the dramatic landscape, sets the tone for an unforgettable experience.



**ROBERT
CHARLES
REULAND JR.**

DOCUMENT USAGE

These drawings were made to fulfill partial requirements for the Thesis Capstone of the FIT Masters Program in the Exhibition and Experience Design by Robert Charles Reuland Jr.

LEGGENDE
DELLA
PIETRA

SITE

The Ruins of Santa Maria del Piano
02030 Pozzaglia Sabino RI, Italy

CLIENT

The Italian Ministry of Culture
Via del Collegio Romano 27, in central Rome)

KEY PLAN

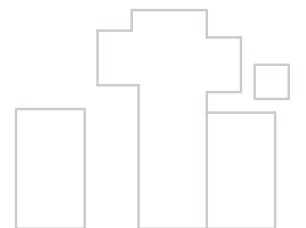

DRAFTED BY Robert Reuland

DATE Dec 9, 2024

SCALE N/A

NAME OF DRAWING

PRE VISIT ARRIVAL

EX.01.09

MANAGEMENT / STEWARDSHIP

The experience will be hosted by the local community selecting a series of volunteers from the surrounding township comprised of mainly retirees. These older community members will manage the site acting as stewards facilitating the experience while also adding additional local accounts and information.

The stewardship program invites the town's elderly to actively engage in sharing the history and stories of Santa Maria del Piano, offering them a renewed sense of pride in their heritage, and fostering social connections. As they guide visitors through the abbey and recount personal memories and local legends, they become ambassadors of their cultural legacy, creating meaningful exchanges with both tourists and the local community. This initiative not only enriches the exhibition experience but also strengthens intergenerational ties and reinforces the importance of preserving shared history.

Responsibilities

- Guiding visitors
- Making sure the ruins are respected
- Ensuring safety
- Answering questions
- Providing personal accounts



Pietro, a friend I made on the visit



**ROBERT
CHARLES
REULAND JR.**

DOCUMENT USAGE

These drawings were made to fulfill partial requirements for the Thesis Capstone of the FIT Masters Program in the Exhibition and Experience Design by Robert Charles Reuland Jr.

LEGGENDE
DELLA
PIETRA

SITE

The Ruins of Santa Maria del Piano
02030 Pozzaglia Sabino RI, Italy

CLIENT

The Italian Ministry of Culture
Via del Collegio Romano 27, in central Rome)

KEY PLAN



DRAFTED BY Robert Reuland
DATE Dec 9, 2024
SCALE N/A

MANAGEMENT

DRAWING NUMBER
EX.01.10



ROBERT CHARLES REULAND JR.

DOCUMENT USAGE

These drawings were made to fulfill partial requirements for the Thesis Capstone of the FIT Masters Program in the Exhibition and Experience Design by Robert Charles Reuland Jr.

LEGGENDE
DELLA
PIETRA

SITE

The Ruins of Santa Maria del Piano
02030 Pozzaglia Sabino RI, Italy

CLIENT

The Italian Ministry of Culture
Via del Collegio Romano 27, in central Rome)

KEY PLAN



DRAFTED BY	Robert Reuland
DATE	Dec 9, 2024
SCALE	N/A

BIRDS EYE VIEW

DRAWING NUMBER
EX.01.11

**ROBERT
CHARLES
REULAND JR.**

DOCUMENT USAGE

These drawings were made to fulfill partial requirements for the Thesis Capstone of the FIT Masters Program in the Exhibition and Experience Design by Robert Charles Reuland Jr.

LEGGENDE
DELLA
PIETRA

SITE

The Ruins of Santa Maria del Piano
02030 Pozzaglia Sabino RI, Italy

CLIENT

The Italian Ministry of Culture
Via del Collegio Romano 27, in central Rome)

KEY PLAN

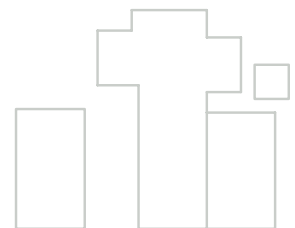

DRAFTED BY Robert Reuland

DATE Dec 9, 2024

SCALE N/A

SIMPLIFIED PLAN

DRAWING NUMBER

EX.01.12

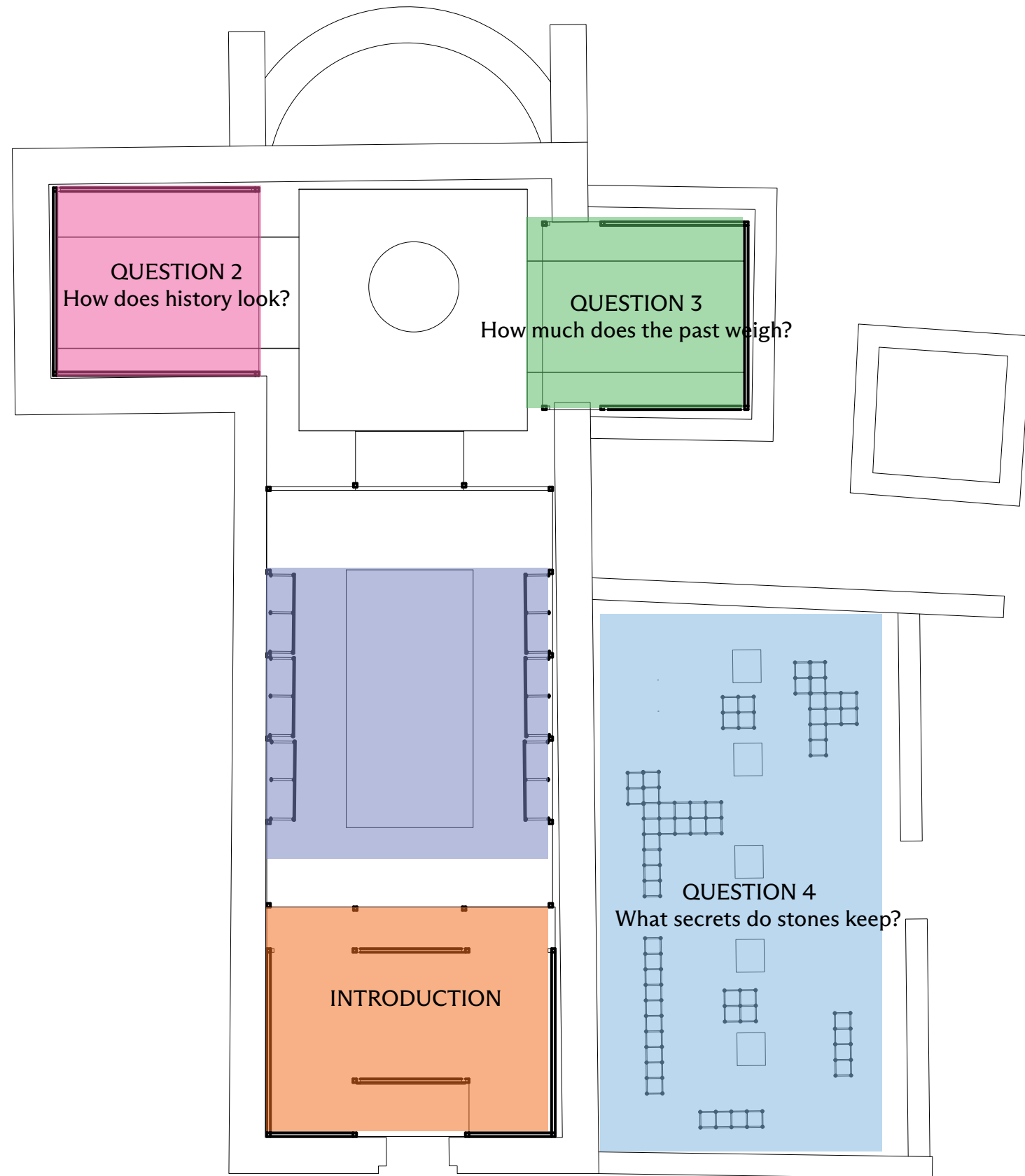

QUESTION 2
How does history look?

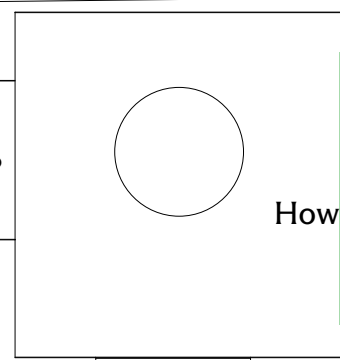

QUESTION 3
How much does the past weigh?

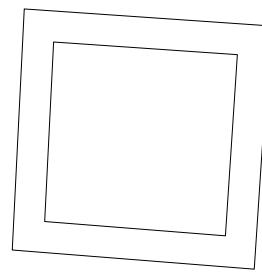

QUESTION 5
are you part of this story?

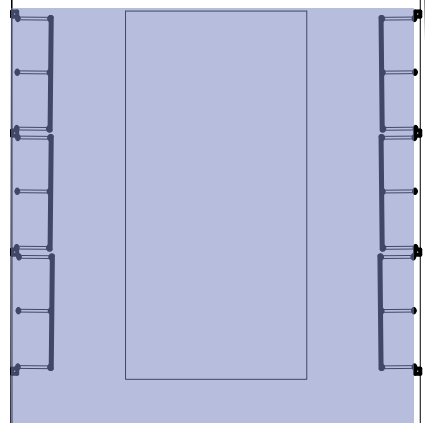
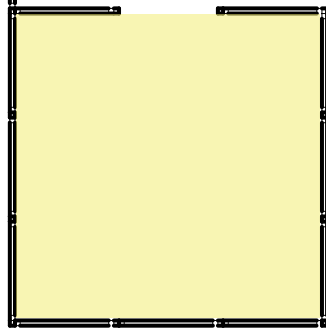

INTRODUCTION

QUESTION 4
What secrets do stones keep?

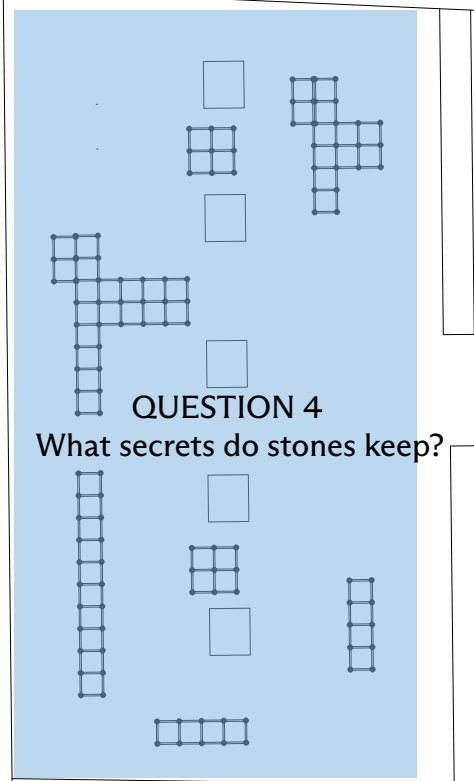



ROBERT CHARLES REULAND JR.

DOCUMENT USAGE

These drawings were made to fulfill partial requirements for the Thesis Capstone of the FIT Masters Program in the Exhibition and Experience Design by Robert Charles Reuland Jr.

LEGGENDE
DELLA
PIETRA

SITE

The Ruins of Santa Maria del Piano
02030 Pozzaglia Sabino RI, Italy

CLIENT

The Italian Ministry of Culture
Via del Collegio Romano 27, in central Rome)

KEY PLAN



DRAFTED BY	Robert Reuland
DATE	Dec 9, 2024
SCALE	N/A

WELCOME

DRAWING NUMBER
EX.01.13



**ROBERT
CHARLES
REULAND JR.**

DOCUMENT USAGE

These drawings were made to fulfill partial requirements for the Thesis Capstone of the FIT Masters Program in the Exhibition and Experience Design by Robert Charles Reuland Jr.

LEGGENDE
DELLA
PIETRA

SITE

The Ruins of Santa Maria del Piano
02030 Pozzaglia Sabino RI, Italy

CLIENT

The Italian Ministry of Culture
Via del Collegio Romano 27, in central Rome)

KEY PLAN

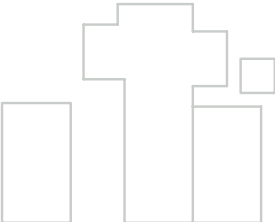

DRAFTED BY	Robert Reuland
DATE	Dec 9, 2024
SCALE	N/A

INTRODUCTION

DRAWING NUMBER
EX.01.14



**ROBERT
CHARLES
REULAND JR.**

DOCUMENT USAGE

These drawings were made to fulfill partial requirements for the Thesis Capstone of the FIT Masters Program in the Exhibition and Experience Design by Robert Charles Reuland Jr.

LEGGENDE
DELLA
PIETRA

SITE

The Ruins of Santa Maria del Piano
02030 Pozzaglia Sabino RI, Italy

CLIENT

The Italian Ministry of Culture
Via del Collegio Romano 27, in central Rome)

KEY PLAN



DRAFTED BY Robert Reuland

DATE Dec 9, 2024

SCALE N/A

QUESTION 1

DRAWING NUMBER

EX.01.15



ROBERT CHARLES REULAND JR.

DOCUMENT USAGE

These drawings were made to fulfill partial requirements for the Thesis Capstone of the FIT Masters Program in the Exhibition and Experience Design by Robert Charles Reuland Jr.

LEGGENDE DELLA PIETRA

SITE

The Ruins of Santa Maria del Piano
02030 Pozzaglia Sabino RI, Italy

CLIENT

The Italian Ministry of Culture
Via del Collegio Romano 27, in central Rome)

KEY PLAN

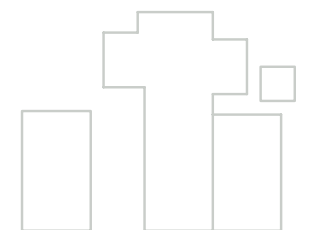

DRAFTED BY Robert Reuland

DATE Dec 9, 2024

SCALE N/A

QUESTION 1

DRAWING NUMBER

EX.01.16



**ROBERT
CHARLES
REULAND JR.**

DOCUMENT USAGE

These drawings were made to fulfill partial requirements for the Thesis Capstone of the FIT Masters Program in the Exhibition and Experience Design by Robert Charles Reuland Jr.

LEGGENDE
DELLA
PIETRA

SITE

The Ruins of Santa Maria del Piano
02030 Pozzaglia Sabino RI, Italy

CLIENT

The Italian Ministry of Culture
Via del Collegio Romano 27, in central Rome)

KEY PLAN

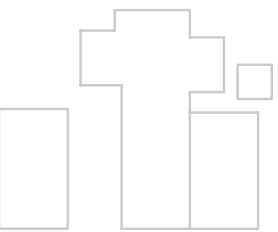

DRAFTED BY	Robert Reuland
DATE	Dec 9, 2024
SCALE	N/A

QUESTION 2

DRAWING NUMBER
EX.01.17



ROBERT CHARLES REULAND JR.

DOCUMENT USAGE

These drawings were made to fulfill partial requirements for the Thesis Capstone of the FIT Masters Program in the Exhibition and Experience Design by Robert Charles Reuland Jr.

LEGGENDE DELLA PIETRA

SITE

The Ruins of Santa Maria del Piano
02030 Pozzaglia Sabino RI, Italy

CLIENT

The Italian Ministry of Culture
Via del Collegio Romano 27, in central Rome)

KEY PLAN



DRAFTED BY Robert Reuland

DATE Dec 9, 2024

SCALE N/A

QUESTION 3

DRAWING NUMBER

EX.01.18



**ROBERT
CHARLES
REULAND JR.**

DOCUMENT USAGE

These drawings were made to fulfill partial requirements for the Thesis Capstone of the FIT Masters Program in the Exhibition and Experience Design by Robert Charles Reuland Jr.

LEGGENDE
DELLA
PIETRA

SITE

The Ruins of Santa Maria del Piano
02030 Pozzaglia Sabino RI, Italy

CLIENT

The Italian Ministry of Culture
Via del Collegio Romano 27, in central Rome)

KEY PLAN



DRAFTED BY Robert Reuland
DATE Dec 9, 2024
SCALE N/A

QUESTION 4

DRAWING NUMBER
EX.01.19



ROBERT CHARLES REULAND JR.

DOCUMENT USAGE

These drawings were made to fulfill partial requirements for the Thesis Capstone of the FIT Masters Program in the Exhibition and Experience Design by Robert Charles Reuland Jr.

LEGGENDE
DELLA
PIETRA

SITE

The Ruins of Santa Maria del Piano
02030 Pozzaglia Sabino RI, Italy

CLIENT

The Italian Ministry of Culture
Via del Collegio Romano 27, in central Rome)

KEY PLAN



DRAFTED BY	Robert Reuland
DATE	Dec 9, 2024
SCALE	N/A

QUESTION 5

DRAWING NUMBER
EX.01.20



**ROBERT
CHARLES
REULAND JR.**

DOCUMENT USAGE

These drawings were made to fulfill partial requirements for the Thesis Capstone of the FIT Masters Program in the Exhibition and Experience Design by Robert Charles Reuland Jr.

LEGGENDE
DELLA
PIETRA

SITE

The Ruins of Santa Maria del Piano
02030 Pozzaglia Sabino RI, Italy

CLIENT

The Italian Ministry of Culture
Via del Collegio Romano 27, in central Rome)

KEY PLAN



DRAFTED BY	Robert Reuland
DATE	Dec 9, 2024
SCALE	N/A

QUESTION 5

DRAWING NUMBER
EX.01.19

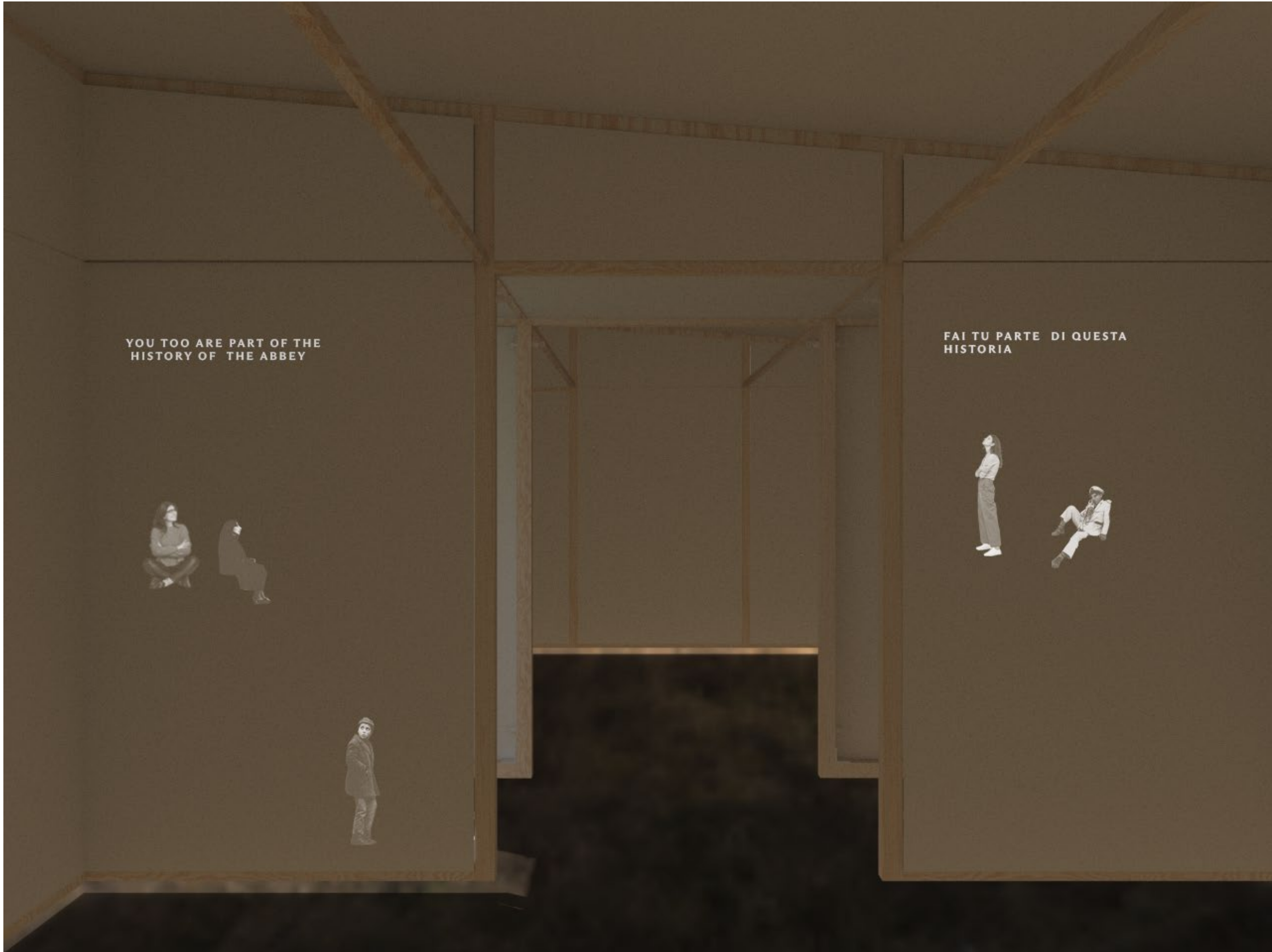

**ROBERT
CHARLES
REULAND JR.**

DOCUMENT USAGE

These drawings were made to fulfill partial requirements for the Thesis Capstone of the FIT Masters Program in the Exhibition and Experience Design by Robert Charles Reuland Jr.

LEGGENDE
DELLA
PIETRA

SITE

The Ruins of Santa Maria del Piano
02030 Pozzaglia Sabino RI, Italy

CLIENT

The Italian Ministry of Culture
Via del Collegio Romano 27, in central Rome)

KEY PLAN

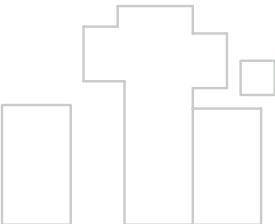

DRAFTED BY	Robert Reuland
DATE	Dec 9, 2024
SCALE	N/A

QUESTION 5

DRAWING NUMBER
EX.01.21



ROBERT CHARLES REULAND JR.

DOCUMENT USAGE

These drawings were made to fulfill partial requirements for the Thesis Capstone of the FIT Masters Program in the Exhibition and Experience Design by Robert Charles Reuland Jr.

LEGGENDE
DELLA
PIETRA

SITE

The Ruins of Santa Maria del Piano
02030 Pozzaglia Sabino RI, Italy

CLIENT

The Italian Ministry of Culture
Via del Collegio Romano 27, in central Rome)

KEY PLAN



DRAFTED BY Robert Reuland

DATE Dec 9, 2024

SCALE N/A

FILM SCREENING

DRAWING NUMBER

EX.01.22



SCHEDULES + LISTS

GRAPHIC SCHEDULE

GRAPHIC CODE	GRAPHIC TYPE	NOTES
INTRODUCTION AREA		
01A.01.GR01	C	INTRODUCTION TO EXPERIENCE EN + IT
01A.01.GR02	C	INTRODUCTION TO EXPERIENCE EN + IT
		DIGITAL MEDIA ROSE WINDOW
QUESTION 1 (WHAT DOES HISTORY SOUND LIKE)		
02A.01.GR01	A	AREA INTRO EN + IT
02A.01.GR02	B	EXHIBIT CONTENT PANEL EN + IT
02A.01.GR03	B	EXHIBIT CONTENT PANEL EN + IT
02A.01.GR04	B	EXHIBIT CONTENT PANEL EN + IT
02A.01.GR05	B	EXHIBIT CONTENT PANEL EN + IT
02A.01.GR06	B	EXHIBIT CONTENT PANEL EN + IT
02A.01.GR07	B	EXHIBIT CONTENT PANEL EN + IT
QUESTION 2 (WHAT DOES HISTORY LOOK LIKE?)		
03A.01.GR01	A	AREA INTRO EN + IT
03A.01.GR02	B	EXHIBIT CONTENT PANEL EN + IT
03A.01.GR03	E	MURAL
03A.01.GR04	E	MURAL
03A.01.GR05	E	MURAL
QUESTION 3 (HOW MUCH DOES THE PAST WEIGH)		
04A.01.GR01	A	AREA INTRO EN + IT
04A.01.GR02	B	EXHIBIT CONTENT PANEL EN + IT
04A.01.GR03	D	PLEASE DON'T TOUCH EN + IT

GRAPHIC CODE	GRAPHIC TYPE	NOTES
QUESTION 4 (WHAT SECRETS DO STONES KEEP?)		
05A.01.GR02	A	AREA INTRO IN + IT
05A.01.GR02	B	EXHIBIT CONTENT EN + IT
05A.01.GR03	B	EXHIBIT CONTENT EN + IT
05A.01.GR04	B	EXHIBIT CONTENT EN + IT
05A.01.GR05	B	EXHIBIT CONTENT EN + IT
05A.01.GR06	B	EXHIBIT CONTENT EN + IT
QUESTION 5 (ARE YOU PART OF THIS STORY?)		
06A.01.GR01	A	AREA INTRO IN + IT
PROGRAMMING		
07A.01.GR01	F	SCREENING ADVERTISEMENT
WAY-FINDING		
08A.01.GR01	G	MAP
081.01.GR02	H	DIRECTIONAL SIGN

ROBERT CHARLES REULAND JR.

DOCUMENT USAGE

These drawings were made to fulfill partial requirements for the Thesis Capstone of the FIT Masters Program in the Exhibition and Experience Design by Robert Charles Reuland Jr.

LEGGENDE
DELLA
PIETRA

SITE

The Ruins of Santa Maria del Piano
02030 Pozzaglia Sabino RI, Italy

CLIENT

The Italian Ministry of Culture
Via del Collegio Romano 27, in central Rome)

KEY PLAN

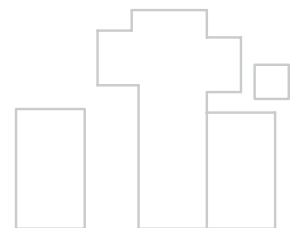

DRAFTED BY Robert Reuland
DATE Dec 9, 2024
SCALE N/A

NAME OF DRAWING

DRAWING NUMBER
EX.00.00

MATERIAL SCHEDULE

CODE	AREA CODE	DESCRIPTION	IMAGE
Wood			
XW-01	01A-07A	PLYWOOD BOARD 1CM THICK 2M X 2M	
XW-02	01A-07A	PINE TIMBER FRAME 10CM THICK 3 M LENGTH	
XW-03	05A	5CM X 5CM WOODEN PINE FOR DISPLAY CASE	
RESIN			
XR-01	01A	BLACK Resin board 1CM THICK 60CM X 60CM	
XR-02	02A-07A	WHITE Resin board 1CM THICK 60CM X 60CM	
X3-03	02A	RED Resin board 1CM THICK 60CM X 60CM	
ROPE			
XRO-01	01A-07A	RED COTTON ROPE 50MM THICK	
XRO-02	02A	WHITE COTTON ROPE 50MM THICK	
FABRIC			
XF.01	06A	CANVAS SAILCLOTH WATER RESISTANT	
XF.02	03A	CHIFFON FABRIC	
PAINT			
XP.01	01A	RED PAINT (ETRUSCAN RED) GLOSSY	
XP.02	01A, 05A	WHITE PAINT (EGGSHELL) MATTE	

ROBERT CHARLES REULAND JR.

DOCUMENT USAGE

These drawings were made to fulfill partial requirements for the Thesis Capstone of the FIT Masters Program in the Exhibition and Experience Design by Robert Charles Reuland Jr.



SITE

The Ruins of Santa Maria del Piano
02030 Pozzaglia Sabino RI, Italy

CLIENT

The Italian Ministry of Culture
Via del Collegio Romano 27, in central Rome)

KEY PLAN

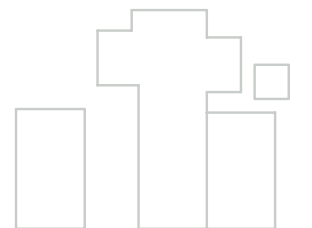

DRAFTED BY Robert Reuland

DATE Dec 9, 2024

SCALE N/A

NAME OF DRAWING

DRAWING NUMBER

EX.00.00

LIGHTING SCHEDULE

CODE	AREA	DESCRIPTION	IMAGE
LT.01	OUTSIDE	OUTDOOR RATED FLOOR WASH	
LT.02	01A-05A	IP20 RATED WALL LINEAR LIGHT FITTING	
LT.03	06A	SPOT LIGHT	
TR.01	06A	TRACK	

**ROBERT
CHARLES
REULAND JR.**

DOCUMENT USAGE

These drawings were made to fulfill partial requirements for the Thesis Capstone of the FIT Masters Program in the Exhibition and Experience Design by Robert Charles Reuland Jr.

LEGGENDE
DELLA
PIETRA

SITE

The Ruins of Santa Maria del Piano
02030 Pozzaglia Sabino RI, Italy

CLIENT

The Italian Ministry of Culture
Via del Collegio Romano 27, in central Rome)

KEY PLAN

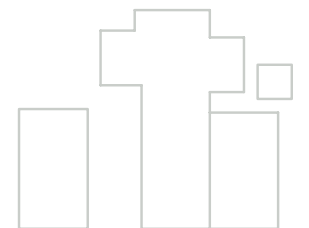

DRAFTED BY Robert Reuland

DATE Dec 9, 2024









SCALE N/A

NAME OF DRAWING

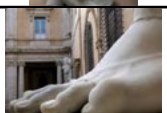
DRAWING NUMBER

EX.00.00

OBJECT LIST

CODE	AREA CODE	DESCRIPTION	IMAGE
AF.1	04A	ROMAN HEAD LIGHTWEIGHT STYROFOAM	
AF.2	04A	ROMAN HAND LIGHTWEIGHT STYROFOAM	
AF.3	04A	ROMAN FOOT LIGHTWEIGHT STYROFOAM	
AF.4	05A	STONE 1	
AF.5	05A	STONE 2	
AF.6	05A	STONE 3	
AF.7	05A	STONE 4	
AF.8	05A	STONE 5	

ROBERT CHARLES REULAND JR.

DOCUMENT USAGE

These drawings were made to fulfill partial requirements for the Thesis Capstone of the FIT Masters Program in the Exhibition and Experience Design by Robert Charles Reuland Jr.

LEGGENDE
DELLA
PIETRA

SITE

The Ruins of Santa Maria del Piano
02030 Pozzaglia Sabino RI, Italy

CLIENT

The Italian Ministry of Culture
Via del Collegio Romano 27, in central Rome)

KEY PLAN

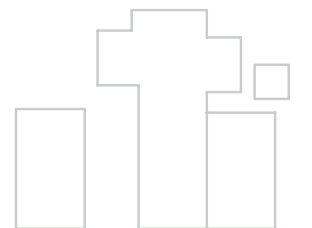

DRAFTED BY Robert Reuland

DATE Dec 9, 2024



SCALE N/A

NAME OF DRAWING

DRAWING NUMBER

EX.00.00

MEDIA SCHEDULE

CODE	AREA CODE	DESCRIPTION	IMAGE
AR.1	01A, 05A, 07A	PROJECTOR 3000K LUMEN	
AR.2	07A	PROJECTOR 5000K LUMEN	
AR.3	02A	OUTDOOR DIRECTIONAL SPEAKERS	

**ROBERT
CHARLES
REULAND JR.**

DOCUMENT USAGE

These drawings were made to fulfill partial requirements for the Thesis Capstone of the FIT Masters Program in the Exhibition and Experience Design by Robert Charles Reuland Jr.

LEGGENDE
DELLA
PIETRA

SITE

The Ruins of Santa Maria del Piano
02030 Pozzaglia Sabino RI, Italy

CLIENT

The Italian Ministry of Culture
Via del Collegio Romano 27, in central Rome)

KEY PLAN

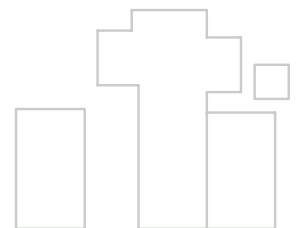

DRAFTED BY Robert Reuland

DATE Dec 9, 2024

SCALE N/A

NAME OF DRAWING

DRAWING NUMBER

EX.00.00

A photograph of a weathered stone wall, likely part of an ancient or historical building. The wall is constructed from irregular, light-colored stones with visible mortar. On the left side, there is a large, arched opening, possibly a window or a doorway, which is currently empty, showing a clear sky. Below the arch, there is a smaller, rectangular opening, also empty. The wall shows signs of age and wear, with some small plants growing from the crevices. The text "PLANS + SECTIONS" is overlaid in the center of the image in a white, serif font.

PLANS + SECTIONS

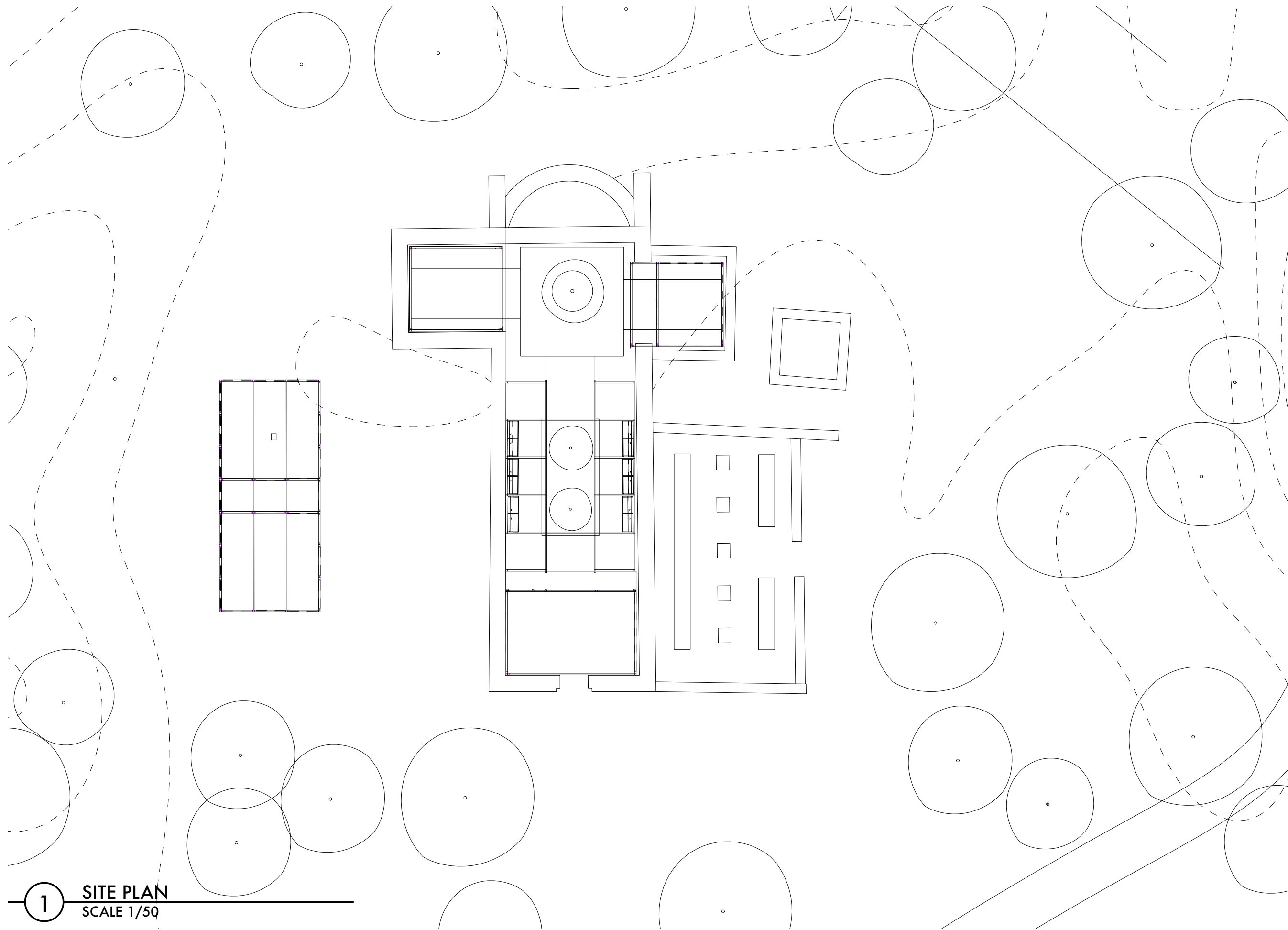

**ROBERT
CHARLES
REULAND JR.**

DOCUMENT USAGE

These drawings were made to fulfill partial requirements for the Thesis Capstone of the FIT Masters Program in the Exhibition and Experience Design by Robert Charles Reuland Jr.

LEGGENDE
DELLA
PIETRA

SITE

The Ruins of Santa Maria del Piano
02030 Pozzaglia Sabino RI, Italy

CLIENT

The Italian Ministry of Culture
Via del Collegio Romano 27, in central Rome)

KEY PLAN

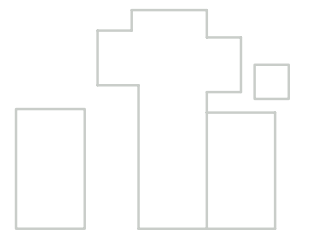

DRAFTED BY Robert Reuland

DATE Dec 9, 2024

SCALE 1/50

SITE PLAN

DRAWING NUMBER

EX.02.01

1 SITE PLAN
SCALE 1/50

DOCUMENT USAGE

These drawings were made to fulfill partial requirements for the Thesis Capstone of the FIT Masters Program in the Exhibition and Experience Design by Robert Charles Reuland Jr.

LEGGENDE
DELLA
PIETRA

SITE

The Ruins of Santa Maria del Piano
02030 Pozzaglia Sabino RI, Italy

CLIENT

The Italian Ministry of Culture
Via del Collegio Romano 27, in central Rome)

KEY PLAN



DRAFTED BY Robert Reuland
DATE Dec 9, 2024
SCALE 1/60

CODED PLAN

DRAWING NUMBER
EX.02.02

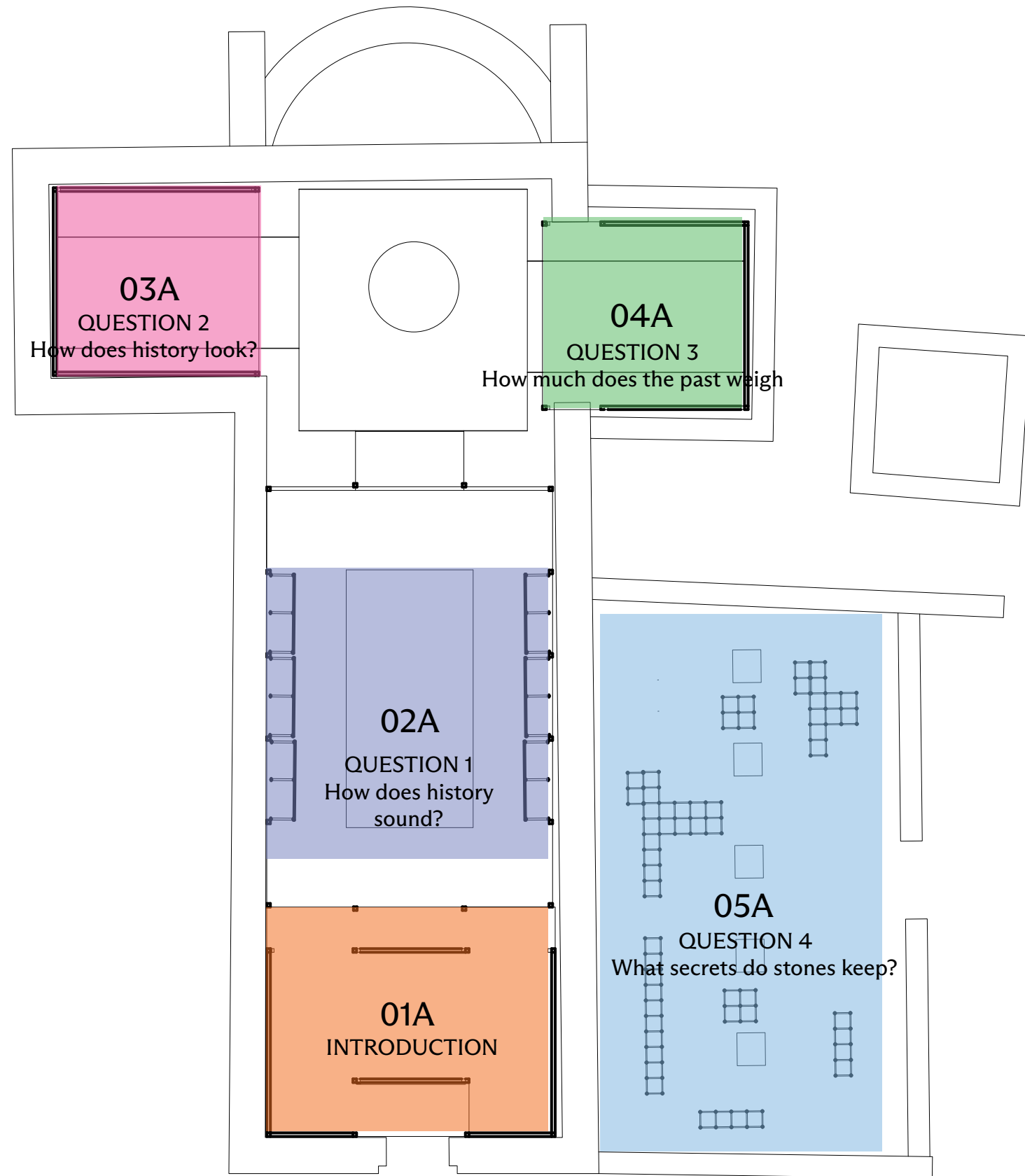

03A
QUESTION 2
How does history look?

04A
QUESTION 3
How much does the past weigh

02A
QUESTION 1
How does history sound?

05A
QUESTION 4
What secrets do stones keep?

01A
INTRODUCTION

06A
QUESTION 5
are you part of this story?

GRAPHIC PLAN

ROBERT
CHARLES
REULAND JR.

DOCUMENT USAGE

These drawings were made to fulfill partial requirements for the Thesis Capstone of the FIT Masters Program in the Exhibition and Experience Design by Robert Charles Reuland Jr.

LEGGENDE
DELLA
PIETRA

SITE

The Ruins of Santa Maria del Piano
02030 Pozzaglia Sabino RI, Italy

CLIENT

The Italian Ministry of Culture
Via del Collegio Romano 27, in central Rome)

KEY PLAN



DRAFTED BY Robert Reuland
DATE Dec 9, 2024
SCALE 1/60

GRAPHIC PLAN

DRAWING NUMBER
EX.02.03

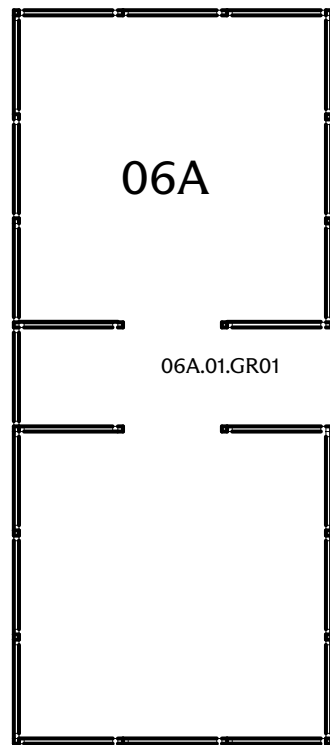
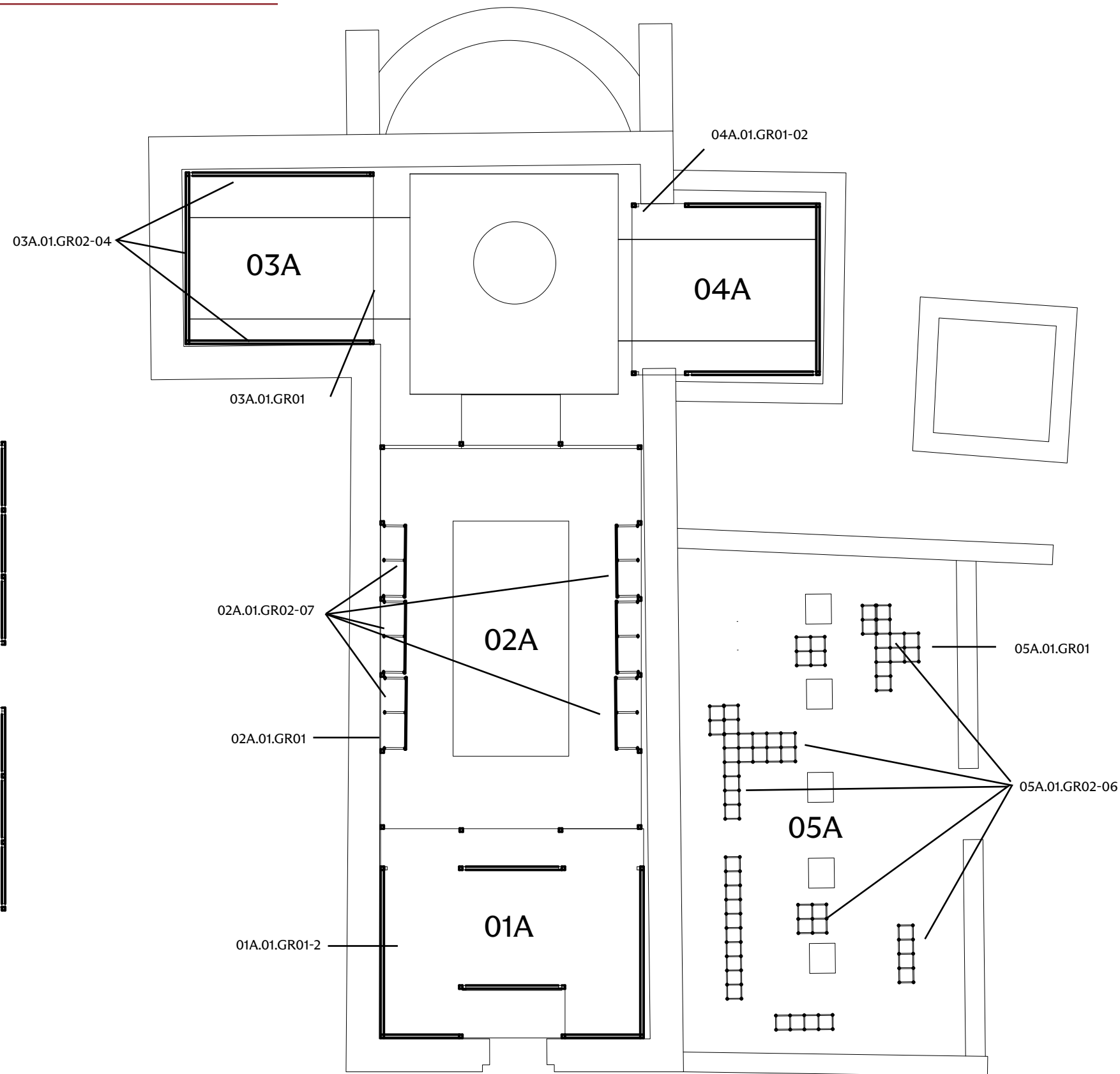

1

GRAPHIC PLAN
SCALE 1/60

DIMENSIONAL PLAN

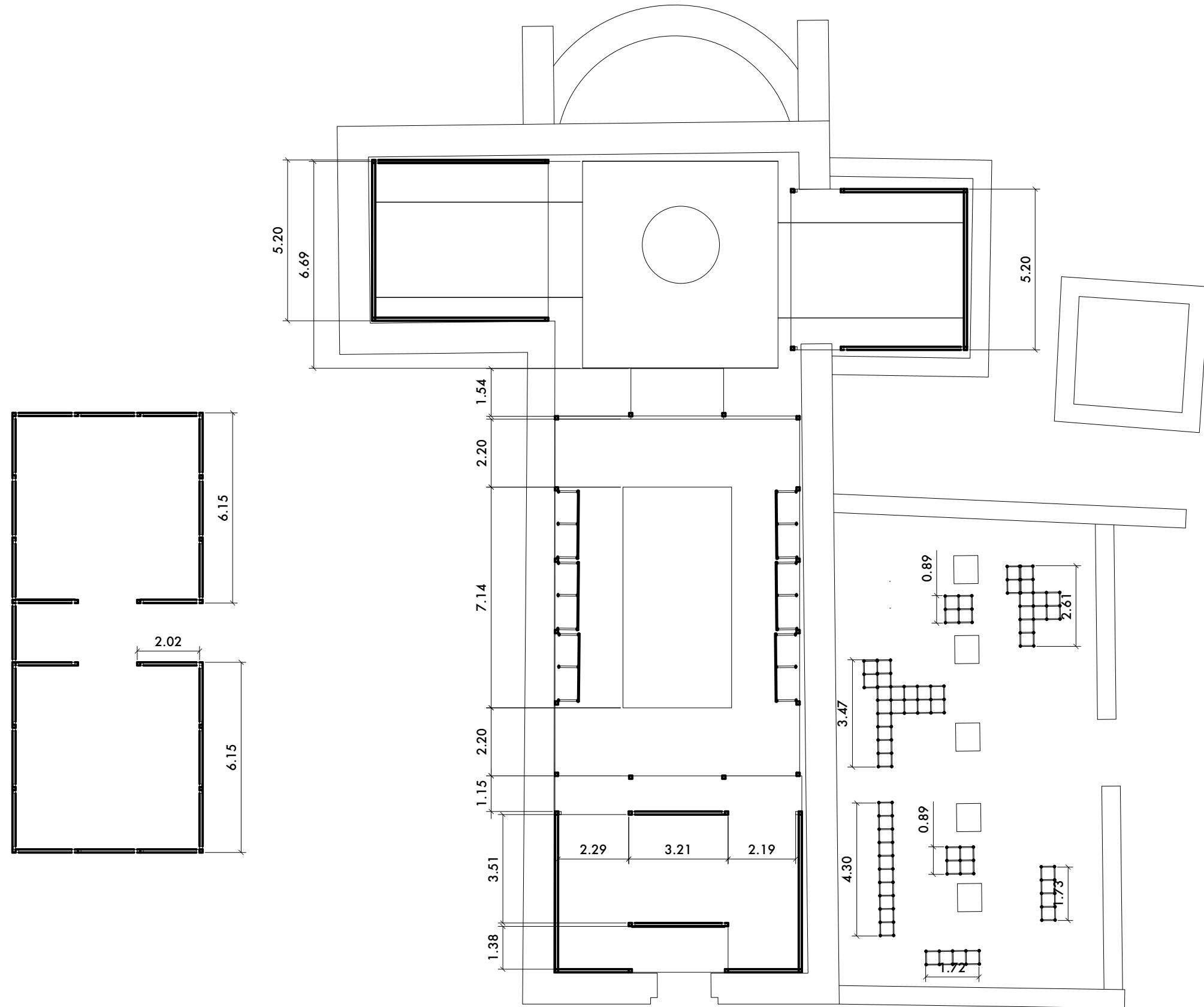

**ROBERT
CHARLES
REULAND JR.**

DOCUMENT USAGE

These drawings were made to fulfill partial requirements for the Thesis Capstone of the FIT Masters Program in the Exhibition and Experience Design by Robert Charles Reuland Jr.

LEGGENDE
DELLA
PIETRA

SITE

The Ruins of Santa Maria del Piano
02030 Pozzaglia Sabino RI, Italy

CLIENT

The Italian Ministry of Culture
Via del Collegio Romano 27, in central Rome)

KEY PLAN



DRAFTED BY Robert Reuland

DATE Dec 9, 2024

SCALE 1/60

DIMENSIONAL PLAN

DRAWING NUMBER

EX.02.04

1

DIMENSIONAL PLAN
SCALE 1/60

DIMENSIONAL PLAN

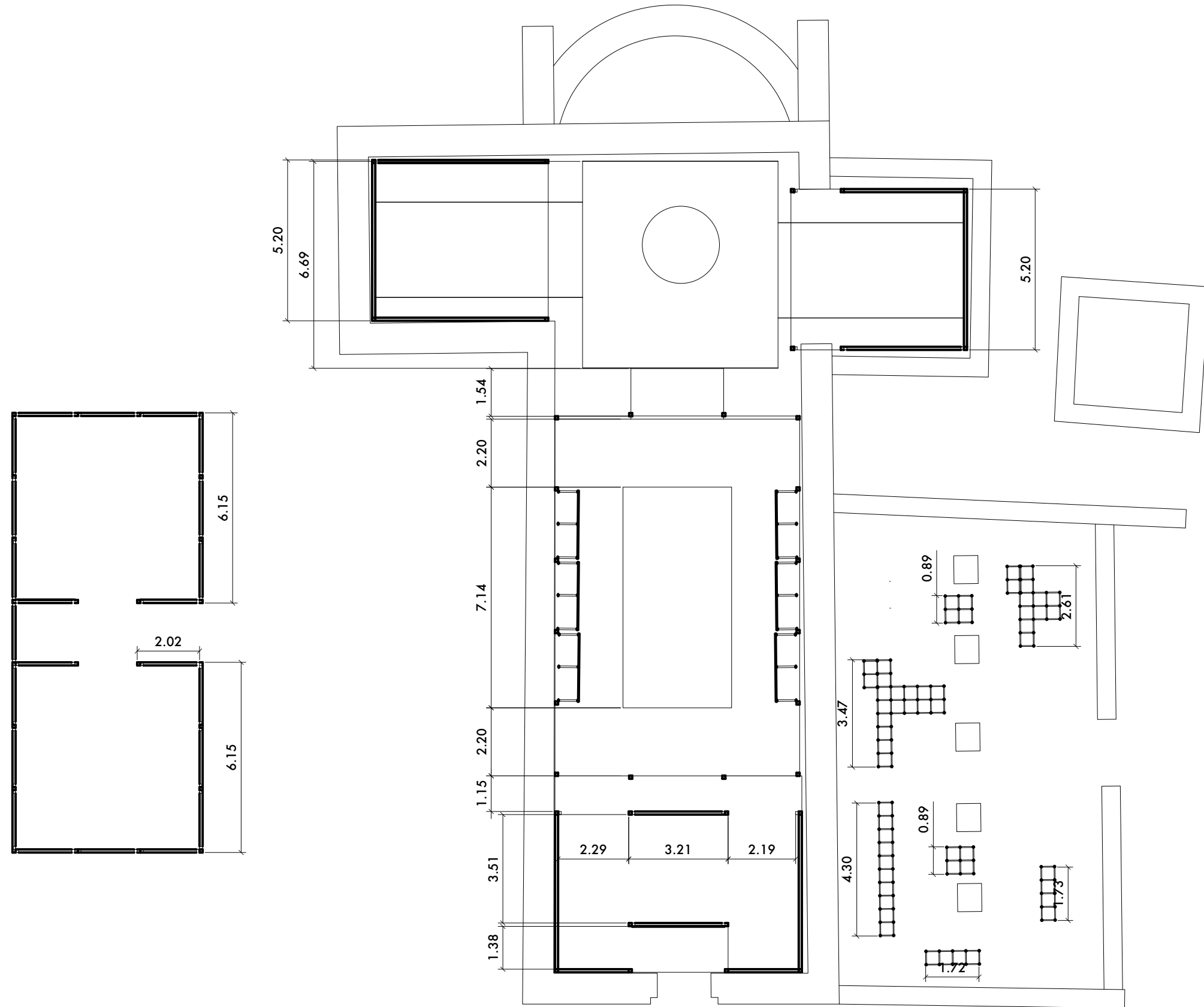

**ROBERT
CHARLES
REULAND JR.**

DOCUMENT USAGE

These drawings were made to fulfill partial requirements for the Thesis Capstone of the FIT Masters Program in the Exhibition and Experience Design by Robert Charles Reuland Jr.

LEGGENDE
DELLA
PIETRA

SITE

The Ruins of Santa Maria del Piano
02030 Pozzaglia Sabino RI, Italy

CLIENT

The Italian Ministry of Culture
Via del Collegio Romano 27, in central Rome)

KEY PLAN



DRAFTED BY Robert Reuland
DATE Dec 9, 2024
SCALE 1/60

DIMENSIONAL PLAN

DRAWING NUMBER
EX.02.04

1

DIMENSIONAL PLAN
SCALE 1/60

MEDIA PLAN

ROBERT
CHARLES
REULAND JR.

DOCUMENT USAGE

These drawings were made to fulfill partial requirements for the Thesis Capstone of the FIT Masters Program in the Exhibition and Experience Design by Robert Charles Reuland Jr.

LEGGENDE
DELLA
PIETRA

SITE

The Ruins of Santa Maria del Piano
02030 Pozzaglia Sabino RI, Italy

CLIENT

The Italian Ministry of Culture
Via del Collegio Romano 27, in central Rome)

KEY PLAN



DRAFTED BY Robert Reuland
DATE Dec 9, 2024
SCALE 1/60

MATERIAL PLAN

DRAWING NUMBER
EX.02.05

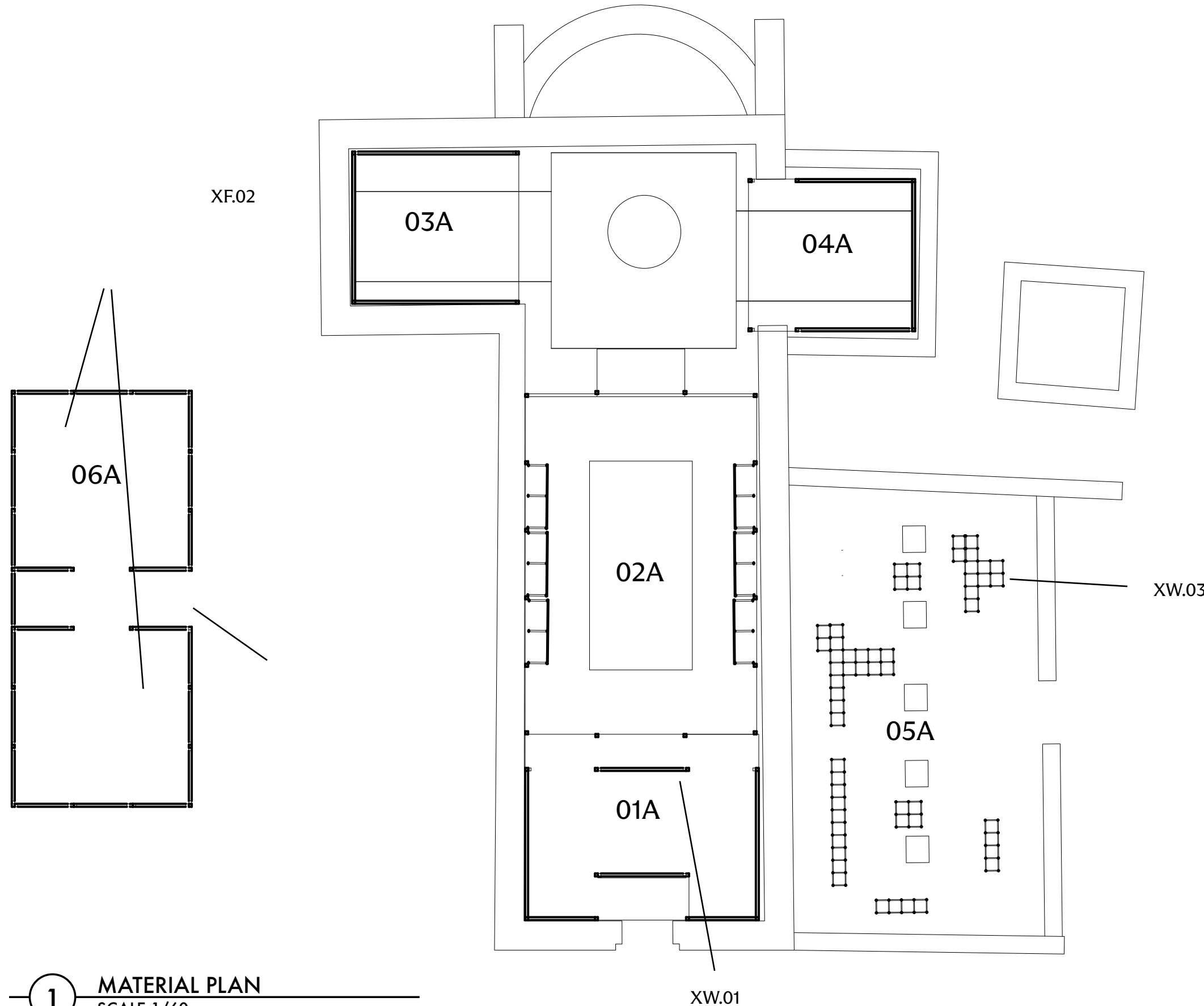

1 MATERIAL PLAN
SCALE 1/60

LIGHTING PLAN

ROBERT
CHARLES
REULAND JR.

DOCUMENT USAGE

These drawings were made to fulfill partial requirements for the Thesis Capstone of the FIT Masters Program in the Exhibition and Experience Design by Robert Charles Reuland Jr.

LEGGENDE
DELLA
PIETRA

SITE

The Ruins of Santa Maria del Piano
02030 Pozzaglia Sabino RI, Italy

CLIENT

The Italian Ministry of Culture
Via del Collegio Romano 27, in central Rome)

KEY PLAN



DRAFTED BY	Robert Reuland
DATE	Dec 9, 2024
SCALE	1/60

LIGHTING PLAN

DRAWING NUMBER
EX.02.06

1 LIGHTING PLAN
SCALE 1/60

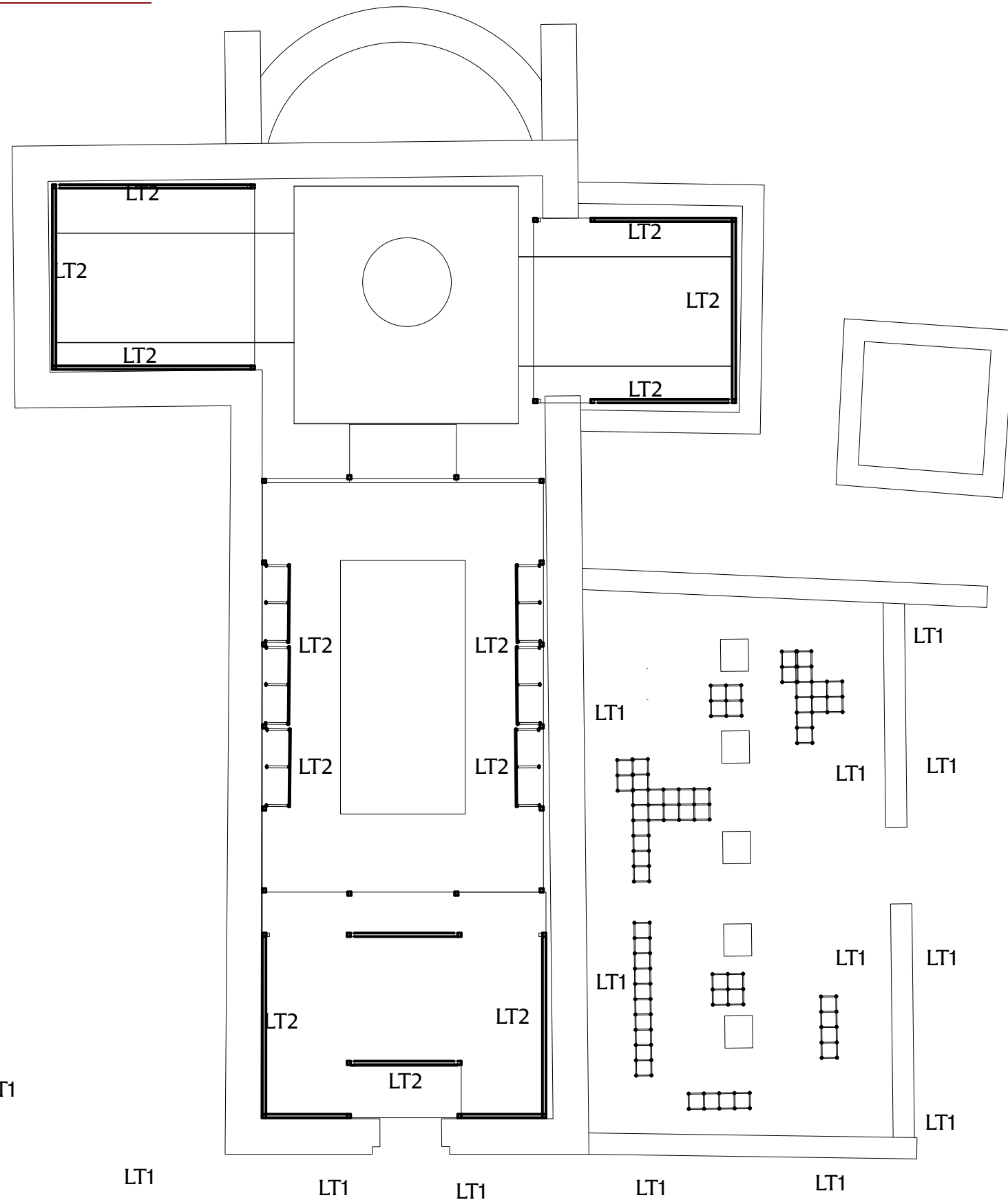

POWER DATA PLAN

ROBERT
CHARLES
REULAND JR.

DOCUMENT USAGE

These drawings were made to fulfill partial requirements for the Thesis Capstone of the FIT Masters Program in the Exhibition and Experience Design by Robert Charles Reuland Jr.

LEGGENDE
DELLA
PIETRA

SITE

The Ruins of Santa Maria del Piano
02030 Pozzaglia Sabino RI, Italy

CLIENT

The Italian Ministry of Culture
Via del Collegio Romano 27, in central Rome)

KEY PLAN



DRAFTED BY Robert Reuland

DATE Dec 9, 2024

SCALE 1/60

POWER DATA PLAN

DRAWING NUMBER

EX.02.07

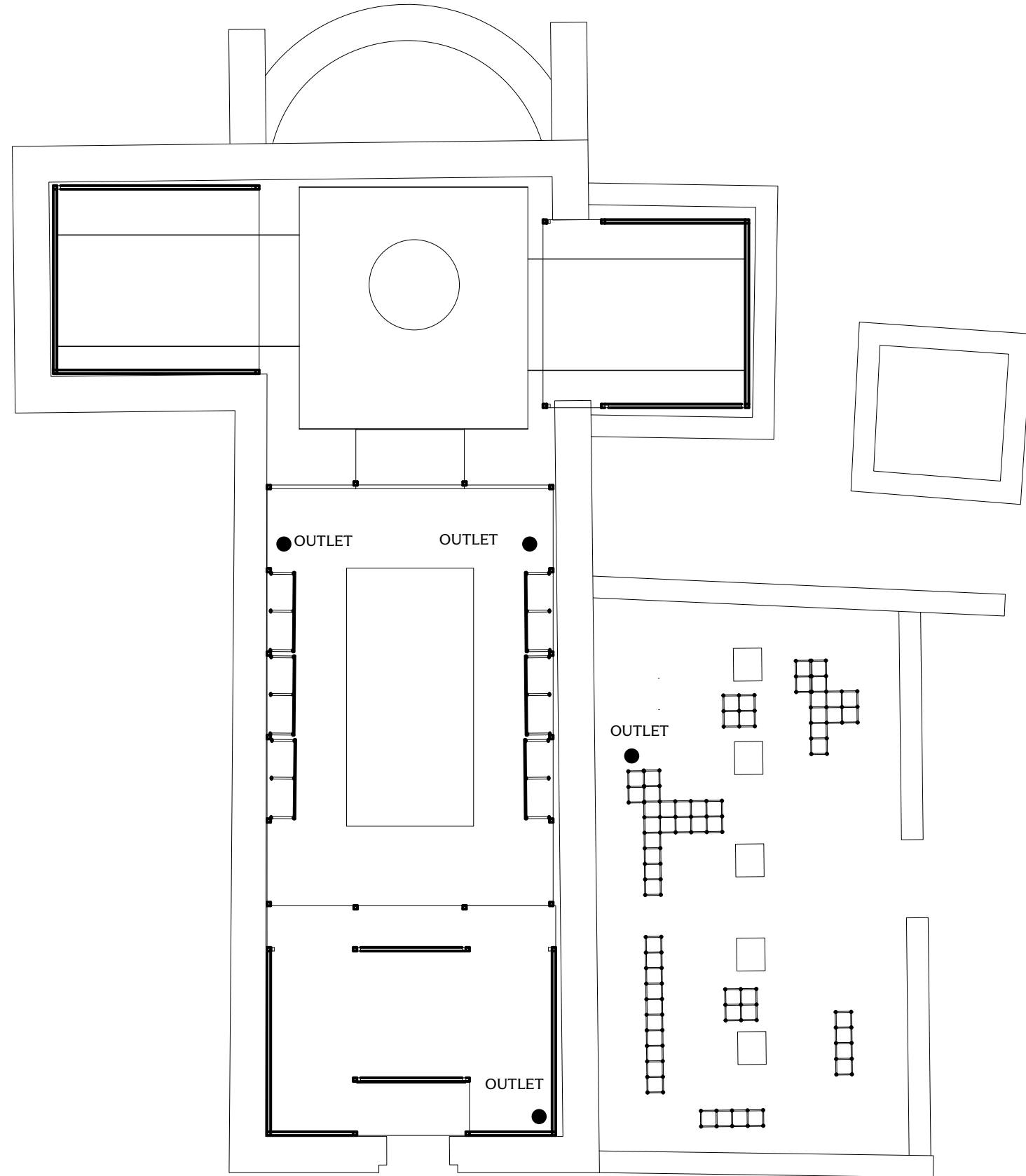

GENERATOR

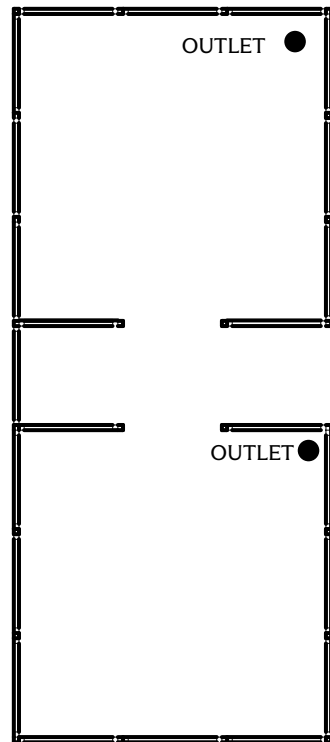

1 POWER DATA PLAN
SCALE 1/160

SOUTH WEST SECTION

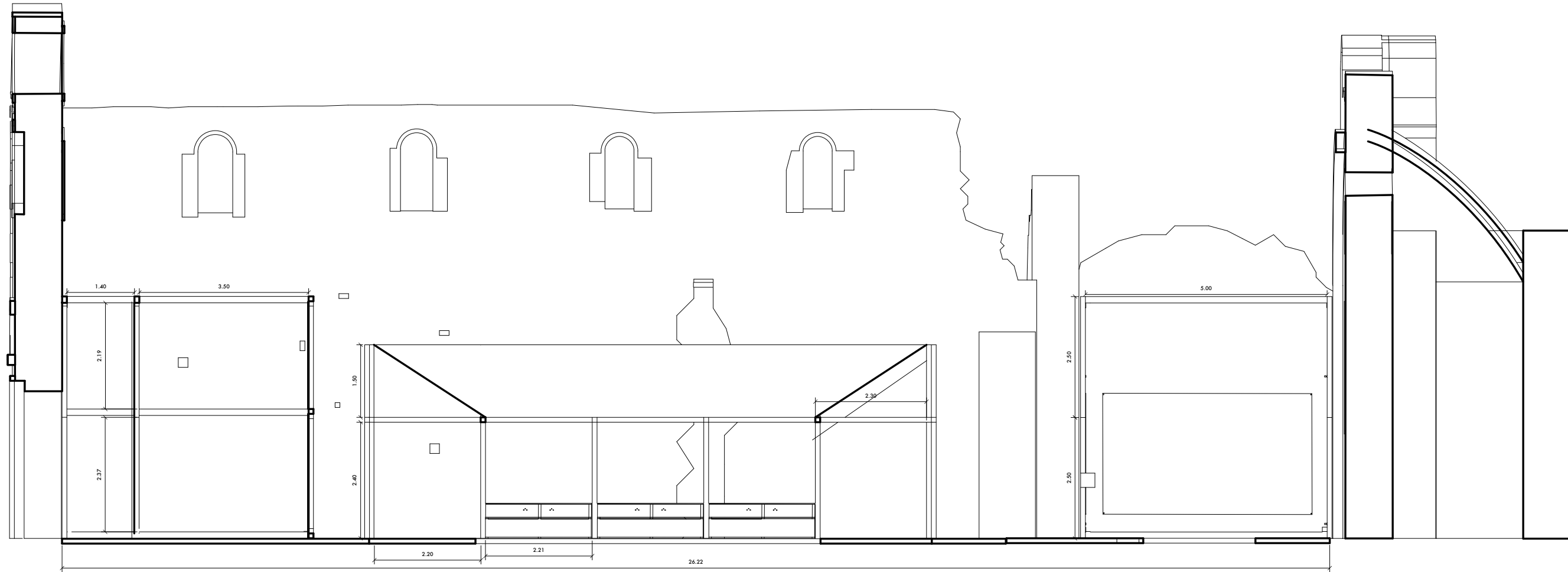

ROBERT
CHARLES
REULAND JR.

DOCUMENT USAGE

These drawings were made to fulfill partial requirements for the Thesis Capstone of the FIT Masters Program in the Exhibition and Experience Design by Robert Charles Reuland Jr.

LEGGENDE
DELLA
PIETRA

SITE

The Ruins of Santa Maria del Piano
02030 Pozzaglia Sabino RI, Italy

CLIENT

The Italian Ministry of Culture
Via del Collegio Romano 27, in central Rome)

KEY PLAN

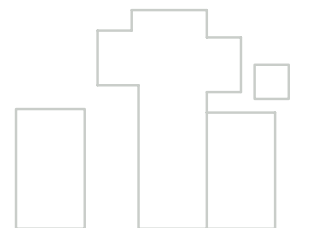

DRAFTED BY Robert Reuland

DATE Dec 9, 2024

SCALE 1/100

SW SECTION

DRAWING NUMBER

EX.02.08

1

SOUTH WEST SECTION
SCALE 1/100

NORTH EAST SECTION

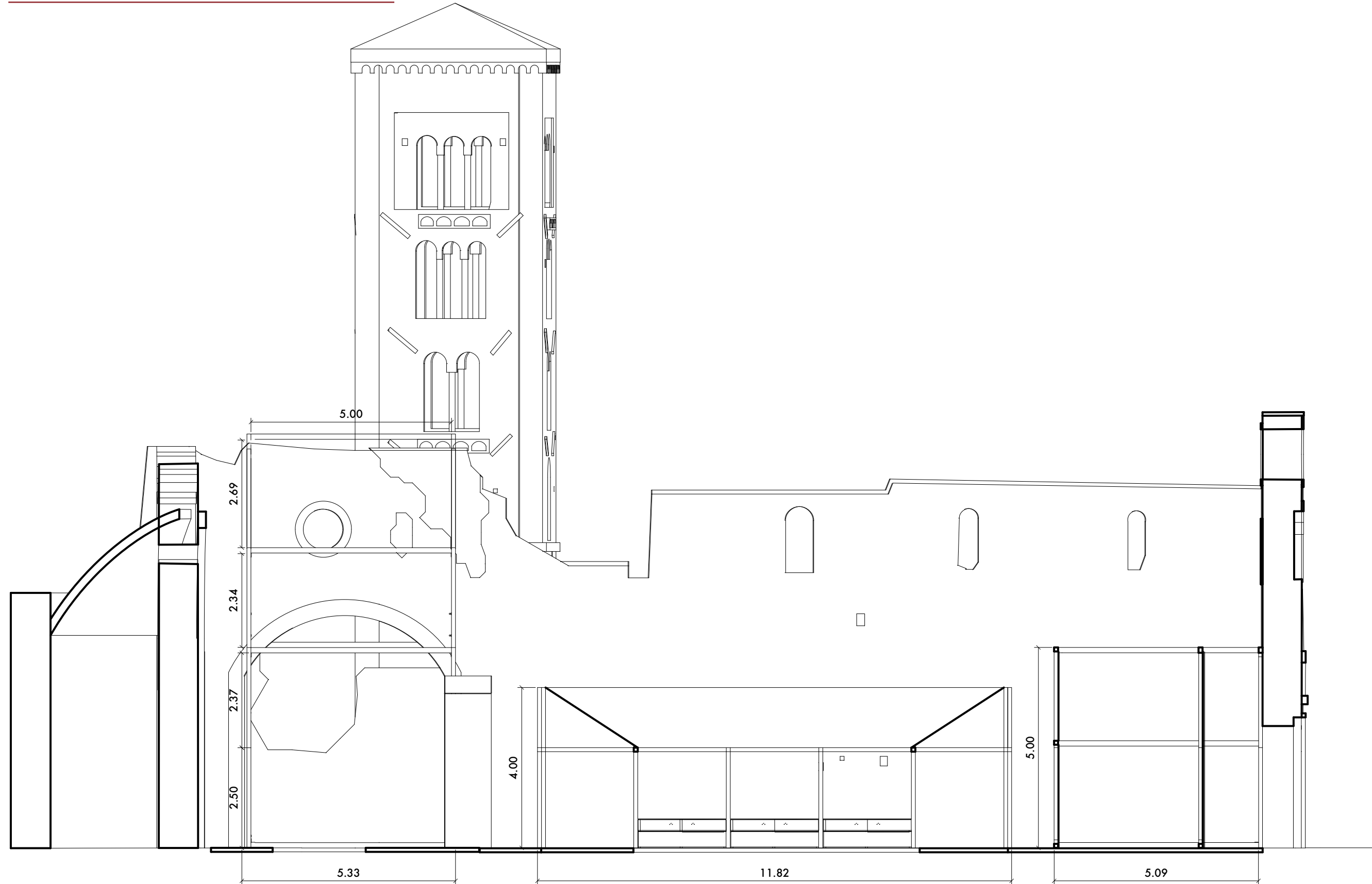

ROBERT
CHARLES
REULAND JR.

DOCUMENT USAGE

These drawings were made to fulfill partial requirements for the Thesis Capstone of the FIT Masters Program in the Exhibition and Experience Design by Robert Charles Reuland Jr.

LEGGENDE
DELLA
PIETRA

SITE

The Ruins of Santa Maria del Piano
02030 Pozzaglia Sabino RI, Italy

CLIENT

The Italian Ministry of Culture
Via del Collegio Romano 27, in central Rome)

KEY PLAN



DRAFTED BY Robert Reuland

DATE Dec 9, 2024

SCALE 1/10

NE SECTION

DRAWING NUMBER

EX.02.09

1 NORTH EAST SECTION
SCALE 1/100

EXPLODED AXONOMETRIC

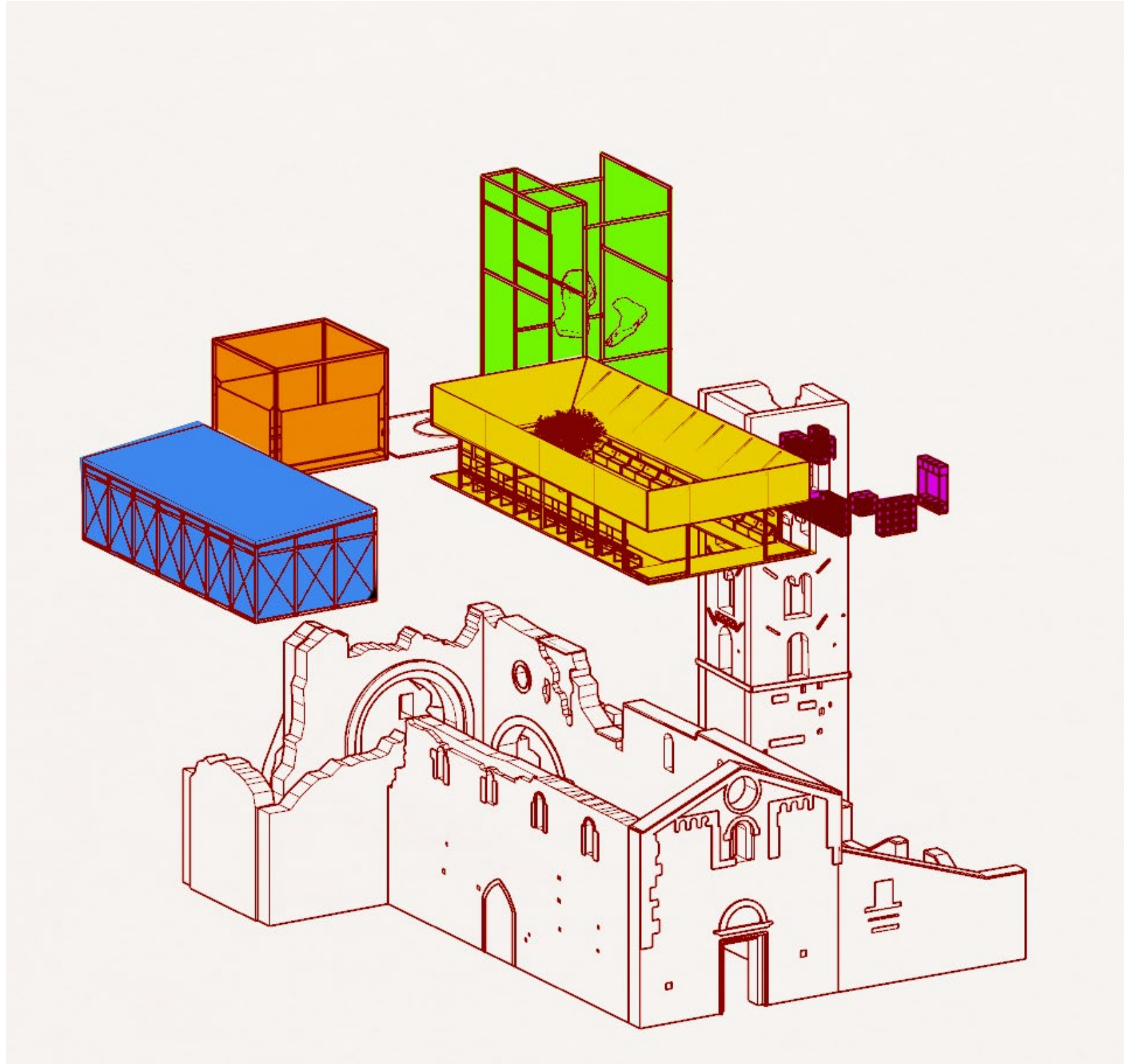

ROBERT
CHARLES
REULAND JR.

DOCUMENT USAGE

These drawings were made to fulfill partial requirements for the Thesis Capstone of the FIT Masters Program in the Exhibition and Experience Design by Robert Charles Reuland Jr.

LEGGENDE
DELLA
PIETRA

SITE

The Ruins of Santa Maria del Piano
02030 Pozzaglia Sabino RI, Italy

CLIENT

The Italian Ministry of Culture
Via del Collegio Romano 27, in central Rome)

KEY PLAN



DRAFTED BY Robert Reuland

DATE Dec 9, 2024

SCALE N/A

NAME OF DRAWING

DRAWING NUMBER

EX.02.10

A landscape photograph featuring a vibrant green field in the foreground, a line of trees in the middle ground, and rolling green hills or mountains in the background under a clear blue sky. A thin, dark branch hangs down from the top left corner. The word "GRAPHICS" is overlaid in the center in a white, serif font.

GRAPHICS

**ROBERT
CHARLES
REULAND JR.**

DOCUMENT USAGE

These drawings were made to fulfill partial requirements for the Thesis Capstone of the FIT Masters Program in the Exhibition and Experience Design by Robert Charles Reuland Jr.

LEGGENDE
DELLA
PIETRA

SITE

The Ruins of Santa Maria del Piano
02030 Pozzaglia Sabino RI, Italy

CLIENT

The Italian Ministry of Culture
Via del Collegio Romano 27, in central Rome)

KEY PLAN



DRAFTED BY	Robert Reuland
DATE	Dec 9, 2024
SCALE	N/A

LOGO

DRAWING NUMBER

EX.03.02

LEGGENDE
DELLA
PIETRA

LEGGENDE
DELLA
PIETRA

GRAPHIC LOOK & FEEL

LEGGENDE
DELLA
PIETRA

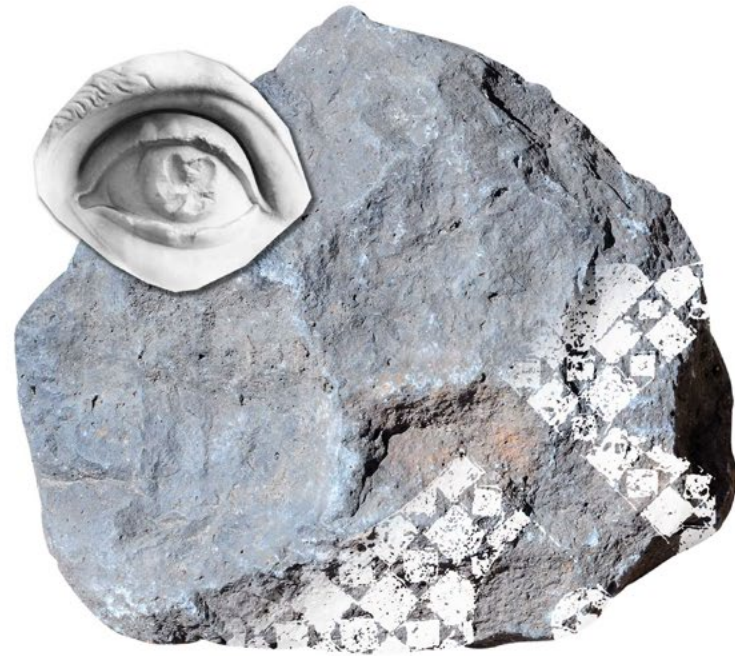

THE ABBEY OF SANTA
MARIA DEL PIANO
POZZALGIA SABINA ITALY

Step into the world of Santa Maria del Piano, where stones whisper the stories of centuries, bearing witness to myths, art, and the enduring spirit of the abbey.

Entra nel mondo di Santa Maria del Piano, dove le pietre sussurrano storie secolari, testimoni di miti, arte e dello spirito eterno dell'abbazia.

OCTOBER 1

LEGGENDE
DELLA
PIETRA



THE ABBEY OF SANTA
MARIA DEL PIANO
POZZALGIA SABINA ITALY

Step into the world of Santa Maria del Piano, where stones whisper the stories of centuries, bearing witness to myths, art, and the enduring spirit of the abbey.

Entra nel mondo di Santa Maria del Piano, dove le pietre sussurrano storie secolari, testimoni di miti, arte e dello spirito eterno dell'abbazia.

OCTOBER 1

ROBERT
CHARLES
REULAND JR.

DOCUMENT USAGE

These drawings were made to fulfill partial requirements for the Thesis Capstone of the FIT Masters Program in the Exhibition and Experience Design by Robert Charles Reuland Jr.

LEGGENDE
DELLA
PIETRA

SITE

The Ruins of Santa Maria del Piano
02030 Pozzaglia Sabina RI, Italy

CLIENT

The Italian Ministry of Culture
Via del Collegio Romano 27, in central Rome)

KEY PLAN

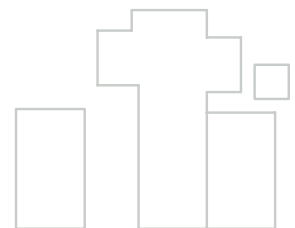

DRAFTED BY Robert Reuland

DATE Dec 9, 2024

SCALE N/A

LOOK + FEEL

DRAWING NUMBER

EX.03.01

COLORS



Pantone 19-1653 TCX



Black



Natural Plywood

ROBERT
CHARLES
REULAND JR.

DOCUMENT USAGE

These drawings were made to fulfill partial requirements for the Thesis Capstone of the FIT Masters Program in the Exhibition and Experience Design by Robert Charles Reuland Jr.

LEGGENDE
DELLA
PIETRA

SITE

The Ruins of Santa Maria del Piano
02030 Pozzaglia Sabino RI, Italy

CLIENT

The Italian Ministry of Culture
Via del Collegio Romano 27, in central Rome)

KEY PLAN



DRAFTED BY Robert Reuland

DATE Dec 9, 2024

SCALE N/A

COLORS

DRAWING NUMBER

EX.03.03

TYPOGRAPHY

ABCDEFGHIJKLMNOPQRSTUVWXYZ
abcdefghijklmnopqrstuvwxyz

ROBERT
CHARLES
REULAND JR.

DOCUMENT USAGE

These drawings were made to fulfill partial requirements for the Thesis Capstone of the FIT Masters Program in the Exhibition and Experience Design by Robert Charles Reuland Jr.

LEGGENDE
DELLA
PIETRA

SITE

The Ruins of Santa Maria del Piano
02030 Pozzaglia Sabino RI, Italy

CLIENT

The Italian Ministry of Culture
Via del Collegio Romano 27, in central Rome)

KEY PLAN



DRAFTED BY	Robert Reuland
DATE	Dec 9, 2024
SCALE	N/A

TYPOGRAPHY

DRAWING NUMBER
EX.03.04

GRAPHIC COLLATERAL

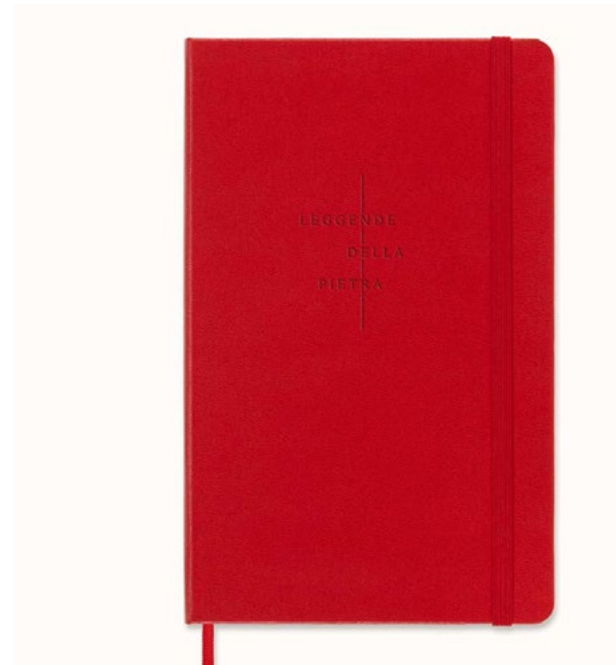

ROBERT
CHARLES
REULAND JR.

DOCUMENT USAGE

These drawings were made to fulfill partial requirements for the Thesis Capstone of the FIT Masters Program in the Exhibition and Experience Design by Robert Charles Reuland Jr.

LEGGENDE
DELLA
PIETRA

SITE

The Ruins of Santa Maria del Piano
02030 Pozzaglia Sabino RI, Italy

CLIENT

The Italian Ministry of Culture
Via del Collegio Romano 27, in central Rome)

KEY PLAN

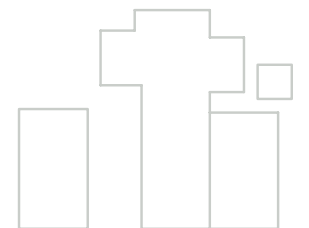

DRAFTED BY Robert Reuland

DATE Dec 9, 2024

SCALE N/A

COLLATERAL

DRAWING NUMBER

EX.03.05

PRE VISIT COLLATERAL

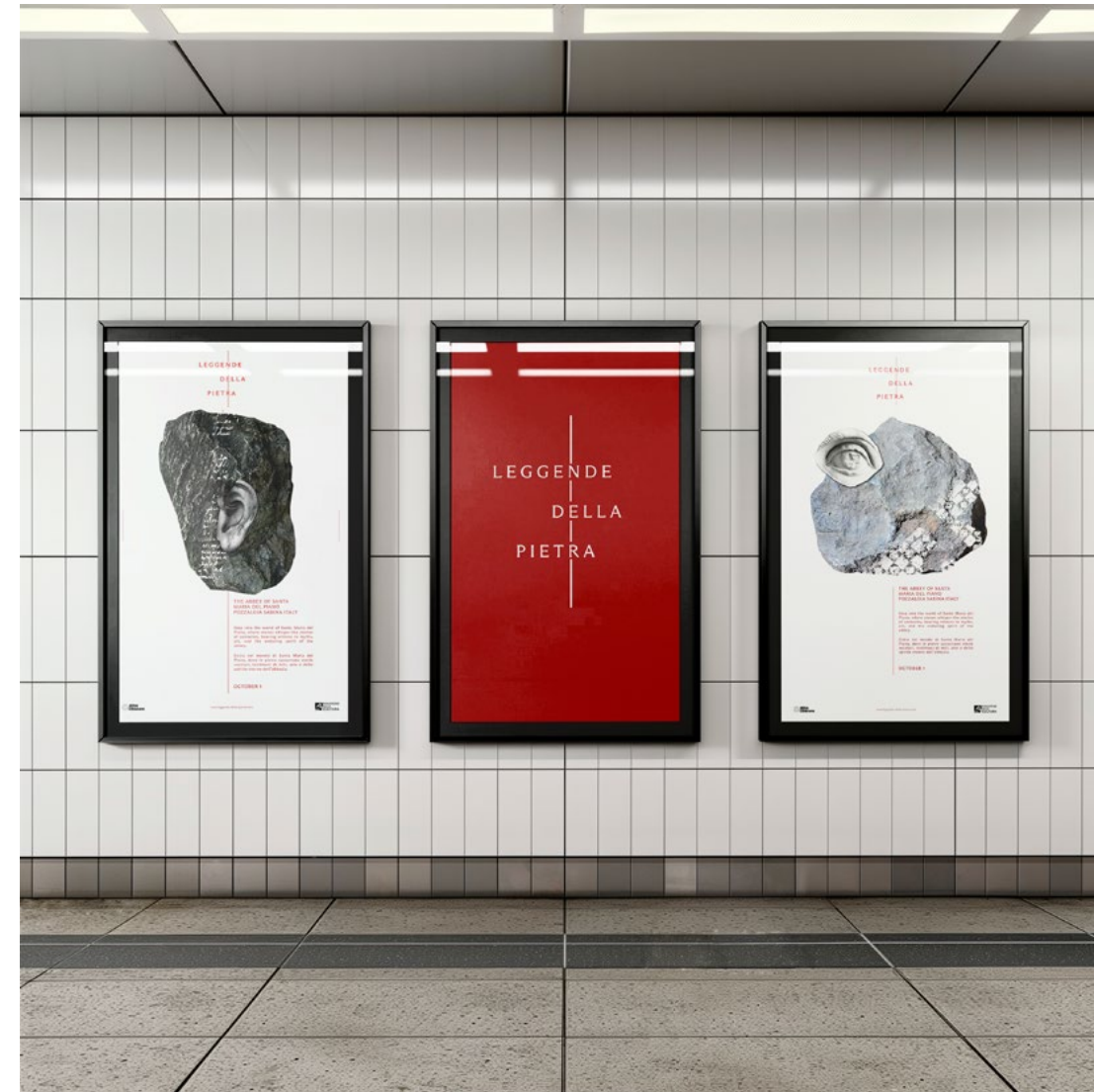

ROBERT
CHARLES
REULAND JR.

DOCUMENT USAGE

These drawings were made to fulfill partial requirements for the Thesis Capstone of the FIT Masters Program in the Exhibition and Experience Design by Robert Charles Reuland Jr.

LEGGENDE
DELLA
PIETRA

SITE

The Ruins of Santa Maria del Pains
02030 Pozzaglia Sabino RI, Italy

CLIENT

The Italian Ministry of Culture
Via del Collegio Romano 27, in central Rome)

KEY PLAN

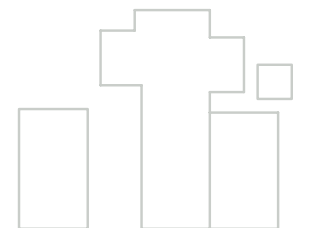

DRAFTED BY Robert Reuland
DATE Dec 9, 2024
SCALE N/A

OOH

DRAWING NUMBER
EX.03.06

**ROBERT
CHARLES
REULAND JR.**

DOCUMENT USAGE

These drawings were made to fulfill partial requirements for the Thesis Capstone of the FIT Masters Program in the Exhibition and Experience Design by Robert Charles Reuland Jr.

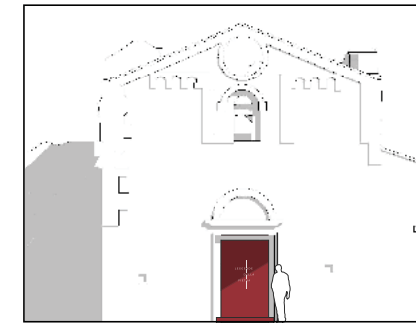

LEGGENDE
DELLA
PIETRA

SITE

The Ruins of Santa Maria del Piano
02030 Pozzaglia Sabino RI, Italy

CLIENT

The Italian Ministry of Culture
Via del Collegio Romano 27, in central Rome)

KEY PLAN

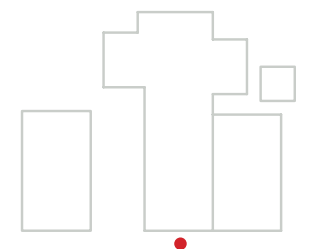

DRAFTED BY Robert Reuland

DATE Dec 9, 2024

SCALE 1/20

WELCOME GRAPHIC

DRAWING NUMBER

EX.03.07

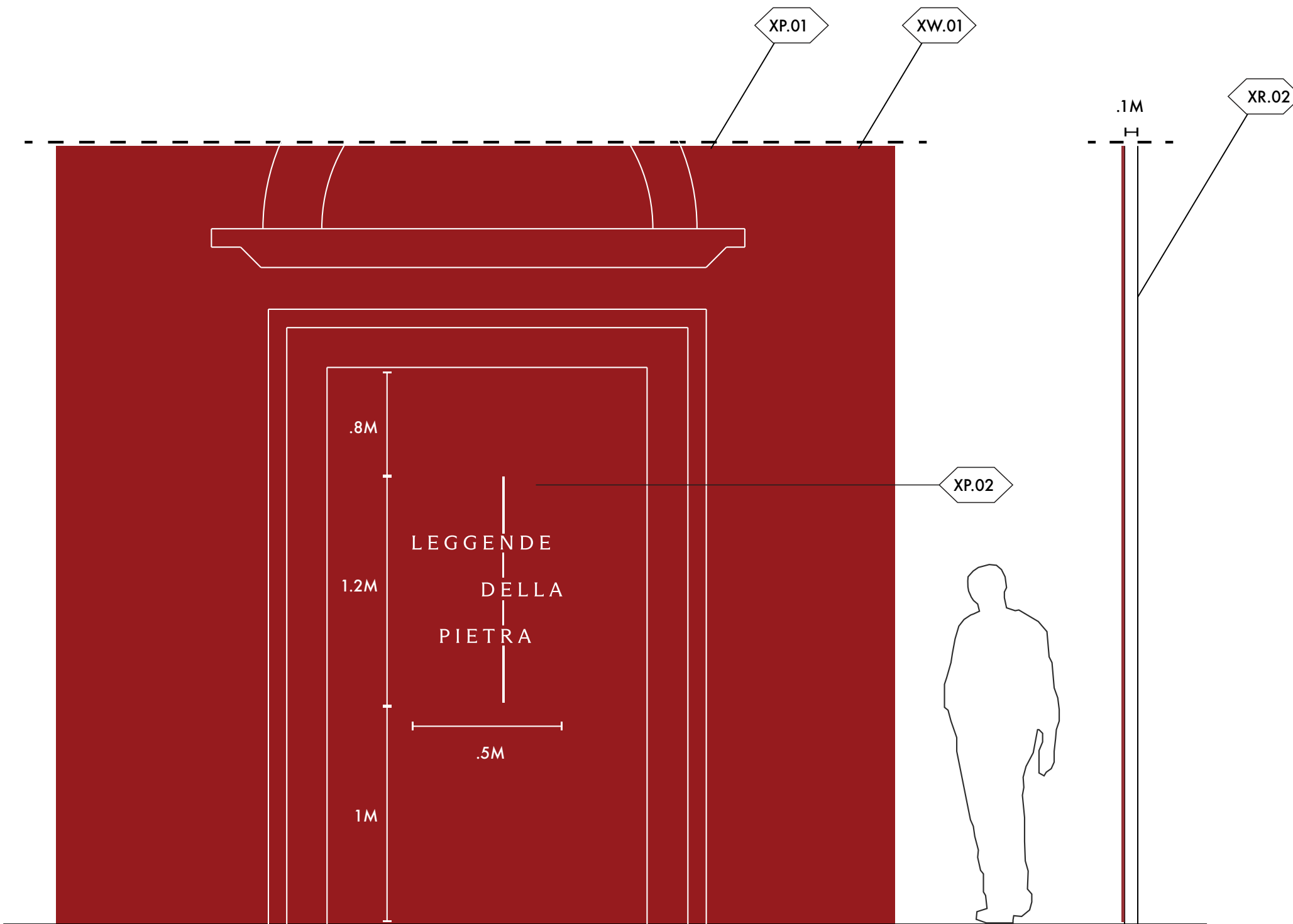

ROBERT CHARLES REULAND JR.

DOCUMENT USAGE

These drawings were made to fulfill partial requirements for the Thesis Capstone of the FIT Masters Program in the Exhibition and Experience Design by Robert Charles Reuland Jr.

LEGGENDE
DELLA
PIETRA

SITE

The Ruins of Santa Maria del Piano
02030 Pozzaglia Sabino RI, Italy

CLIENT

The Italian Ministry of Culture
Via del Collegio Romano 27, in central Rome)

KEY PLAN

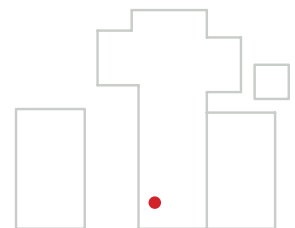

DRAFTED BY Robert Reuland

DATE Dec 9, 2024

SCALE 1/10

INTRO SIGN

DRAWING NUMBER

EX.03.08

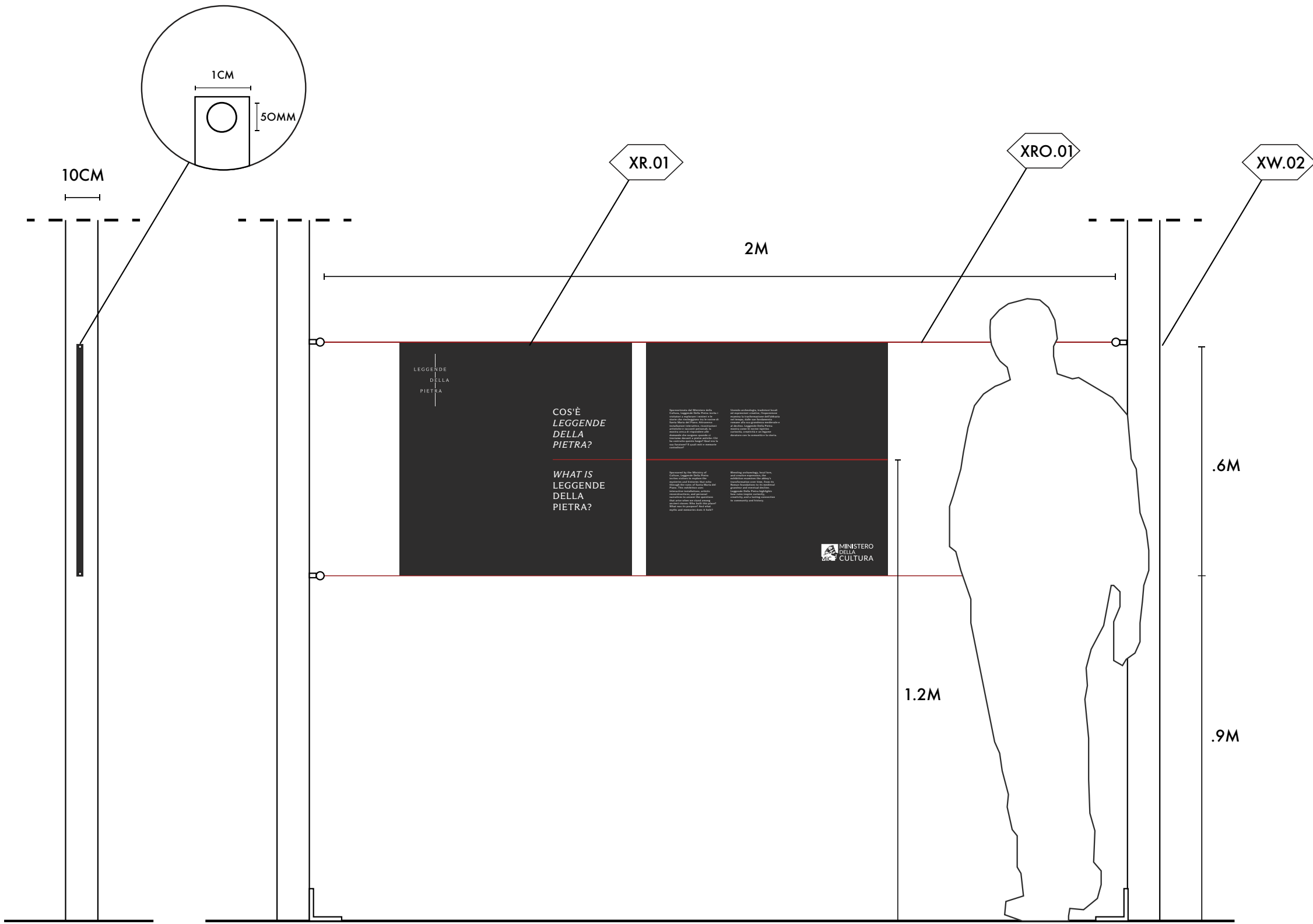

1 INTRO SIGN
SCALE 1/10

ROBERT CHARLES REULAND JR.

DOCUMENT USAGE

These drawings were made to fulfill partial requirements for the Thesis Capstone of the FIT Masters Program in the Exhibition and Experience Design by Robert Charles Reuland Jr.

LEGGENDE
DELLA
PIETRA

SITE

The Ruins of Santa Maria del Piano
02030 Pozzaglia Sabino RI, Italy

CLIENT

The Italian Ministry of Culture
Via del Collegio Romano 27, in central Rome)

KEY PLAN

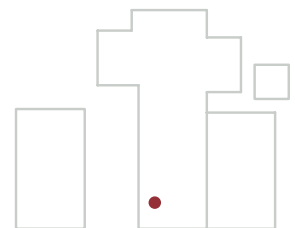

DRAFTED BY Robert Reuland

DATE Dec 9, 2024

SCALE 1/5

INTRO SIGN DETAIL

DRAWING NUMBER

EX.03.09

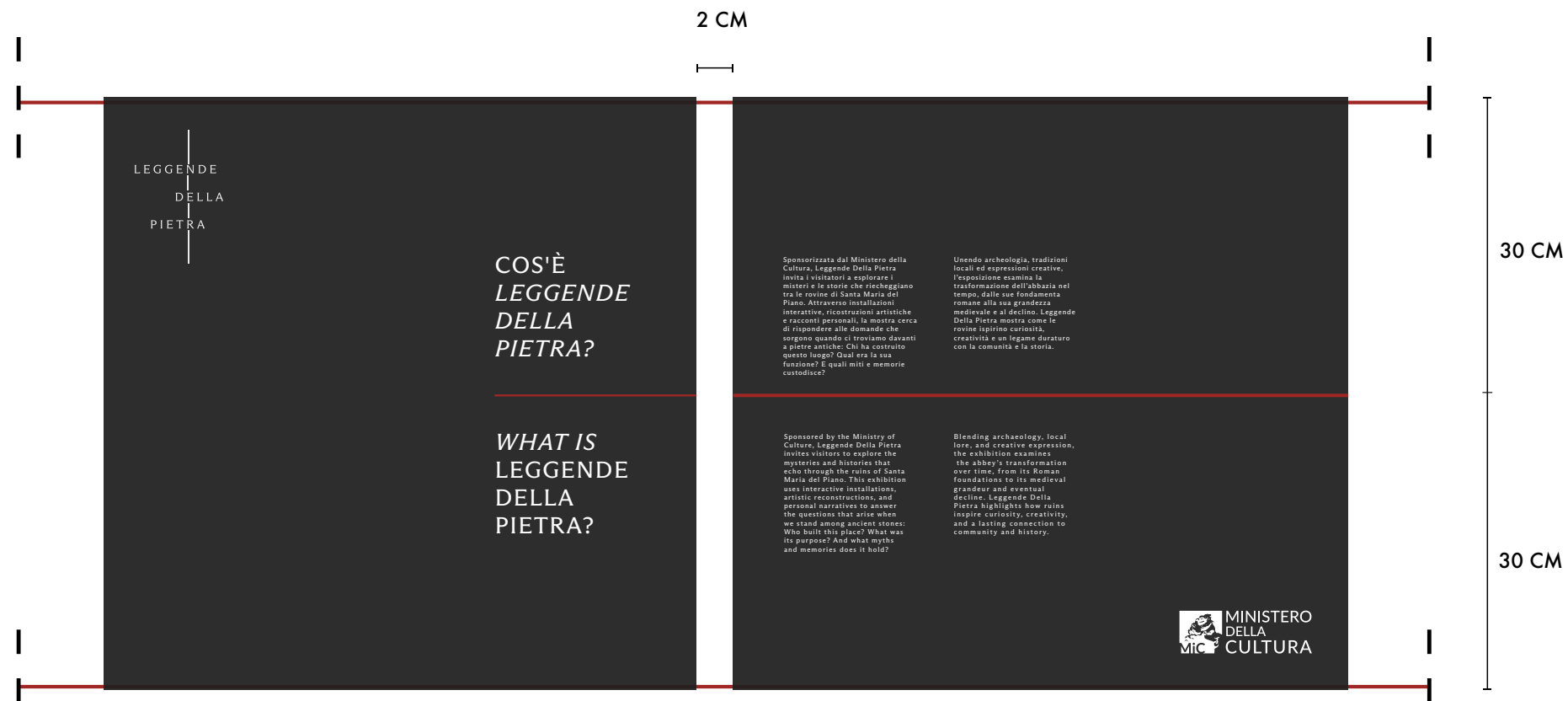

ROBERT CHARLES REULAND JR.

DOCUMENT USAGE

These drawings were made to fulfill partial requirements for the Thesis Capstone of the FIT Masters Program in the Exhibition and Experience Design by Robert Charles Reuland Jr.

LEGGENDE
DELLA
PIETRA

SITE

The Ruins of Santa Maria del Piano
02030 Pozzaglia Sabino RI, Italy

CLIENT

The Italian Ministry of Culture
Via del Collegio Romano 27, in central Rome)

KEY PLAN

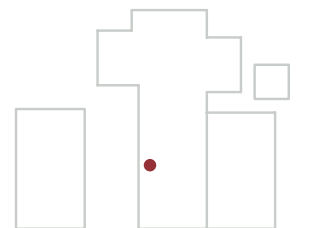

DRAFTED BY Robert Reuland

DATE Dec 9, 2024

SCALE 1/10

EXHIBIT AREA

DRAWING NUMBER

EX.03.10

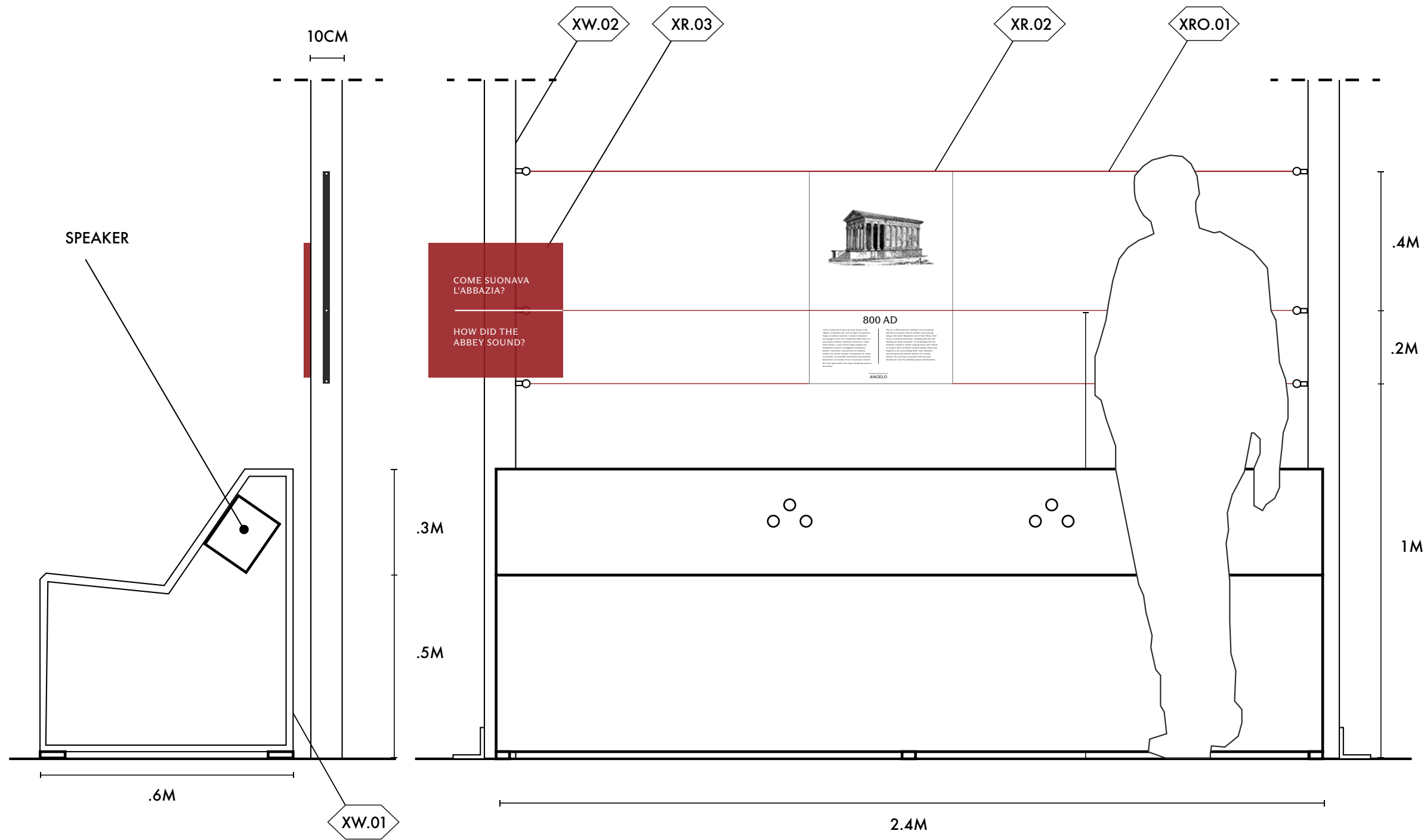

1 EXHIBIT AREA SAMPLE
SCALE 1/10

**ROBERT
CHARLES
REULAND JR.**

DOCUMENT USAGE

These drawings were made to fulfill partial requirements for the Thesis Capstone of the FIT Masters Program in the Exhibition and Experience Design by Robert Charles Reuland Jr.

LEGGENDE
DELLA
PIETRA

SITE

The Ruins of Santa Maria del Piano
02030 Pozzaglia Sabino RI, Italy

CLIENT

The Italian Ministry of Culture
Via del Collegio Romano 27, in central Rome)

KEY PLAN

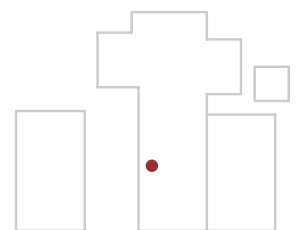

DRAFTED BY Robert Reuland

DATE Dec 9, 2024

SCALE 1/5

AREA INTRO

DRAWING NUMBER
EX.03.11



1 AREA INTRO
SCALE 1/5

ROBERT CHARLES REULAND JR.

DOCUMENT USAGE

These drawings were made to fulfill partial requirements for the Thesis Capstone of the FIT Masters Program in the Exhibition and Experience Design by Robert Charles Reuland Jr.

LEGGENDE DELLA PIETRA

SITE

The Ruins of Santa Maria del Piano
02030 Pozzaglia Sabino RI, Italy

CLIENT

The Italian Ministry of Culture
Via del Collegio Romano 27, in central Rome)

KEY PLAN

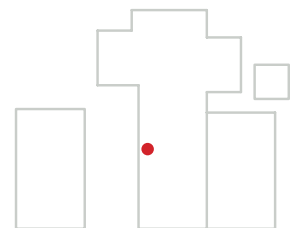

DRAFTED BY Robert Reuland

DATE Dec 9, 2024

SCALE 1/5

CONTENT PANEL

DRAWING NUMBER

EX.03.12

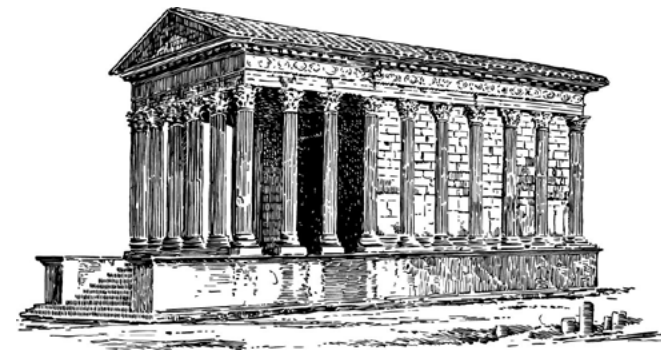

200 AD

L'aria è colma del fruscio dei rami d'ulivo e del cigolio occasionale dei carri di legno che passano lungo un sentiero sterrato. I pastori chiamano i loro greggi, le loro voci trasportate dalla brezza si mescolano al belato sommesso di pecore e capre. Sullo sfondo, i suoni ritmici degli scalpelli che modellano la pietra riecheggiano lievemente mentre i lavoratori costruiscono un modesto tempio. Gli uccelli cantano vivacemente nei campi circostanti, con melodie intervallate dal mormorio distante di un ruscello vicino. Il santuario risuona dei ritmi quieti della vita rurale, fondendo natura e devozione.

The air is filled with the rustling of olive branches and the occasional creak of wooden carts passing along a dirt path. Shepherds call to their flocks, their voices carried by the breeze, mingling with the soft bleating of sheep and goats. In the background, the rhythmic sounds of chisels shaping stone echo faintly as workers labor to build a modest temple. Birds sing brightly in the surrounding fields, their melodies punctuated by the distant murmur of a nearby stream. The sanctuary resonates with the quiet rhythms of rural life, blending nature and devotion.

FOR MORE INFORMATION ASK
ANGELO

**ROBERT
CHARLES
REULAND JR.**

DOCUMENT USAGE

These drawings were made to fulfill partial requirements for the Thesis Capstone of the FIT Masters Program in the Exhibition and Experience Design by Robert Charles Reuland Jr.

LEGGENDE
DELLA
PIETRA

SITE

The Ruins of Santa Maria del Piano
02030 Pozzaglia Sabino RI, Italy

CLIENT

The Italian Ministry of Culture
Via del Collegio Romano 27, in central Rome)

KEY PLAN

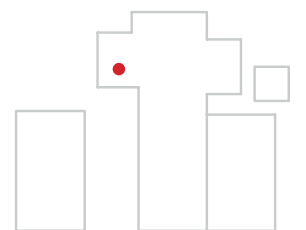

DRAFTED BY Robert Reuland

DATE Dec 9, 2024

SCALE 1/15

MURAL

DRAWING NUMBER

EX.03.13

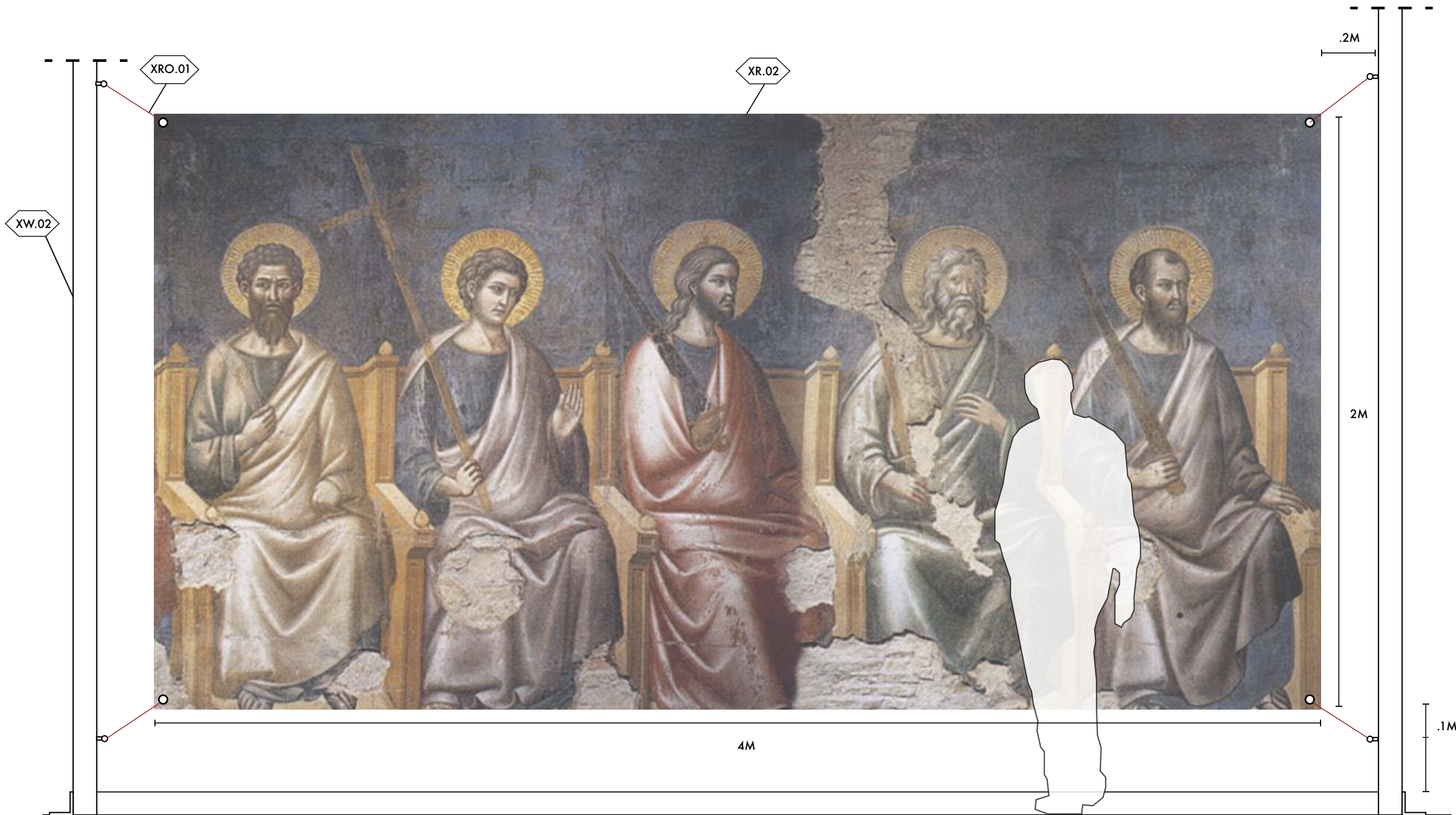

**ROBERT
CHARLES
REULAND JR.**

DOCUMENT USAGE

These drawings were made to fulfill partial requirements for the Thesis Capstone of the FIT Masters Program in the Exhibition and Experience Design by Robert Charles Reuland Jr.

LEGGENDE
DELLA
PIETRA

SITE

The Ruins of Santa Maria del Piano
02030 Pozzaglia Sabino RI, Italy

CLIENT

The Italian Ministry of Culture
Via del Collegio Romano 27, in central Rome)

KEY PLAN

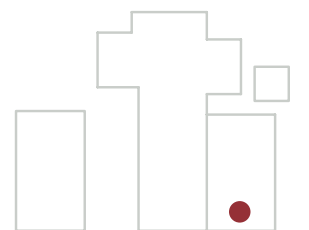

DRAFTED BY Robert Reuland

DATE Dec 9, 2024

SCALE 1/10

MODULAR DISPLAY

DRAWING NUMBER

EX.03.14

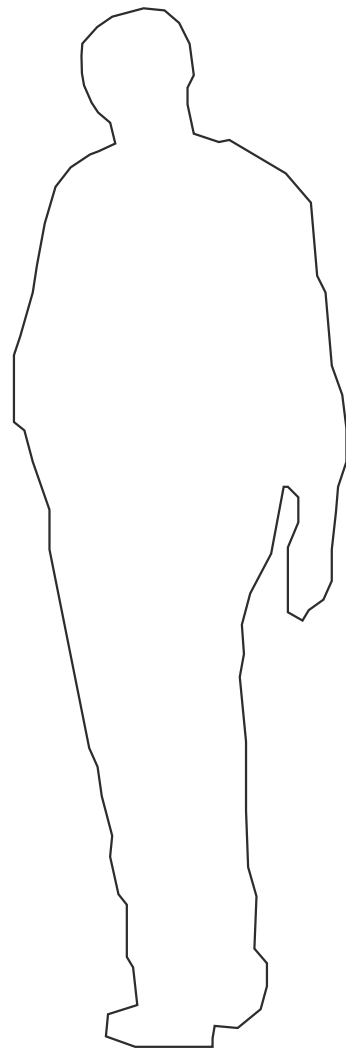
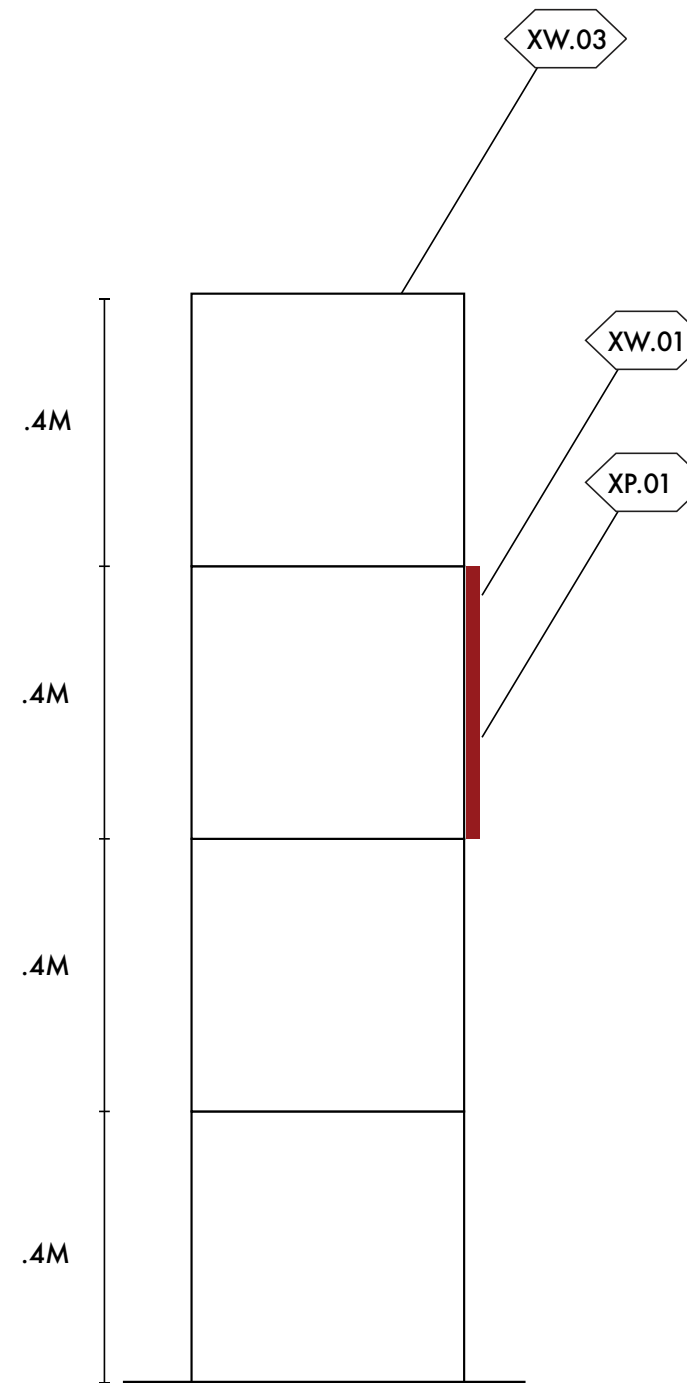
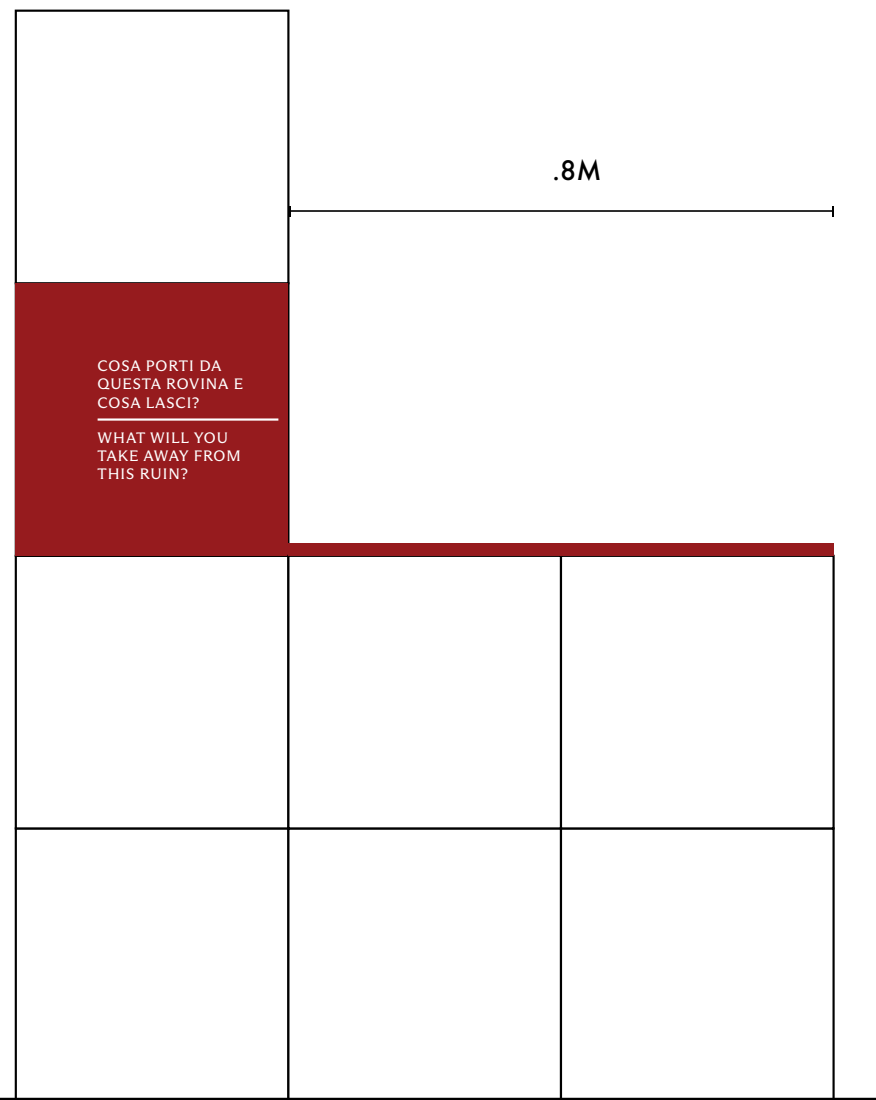
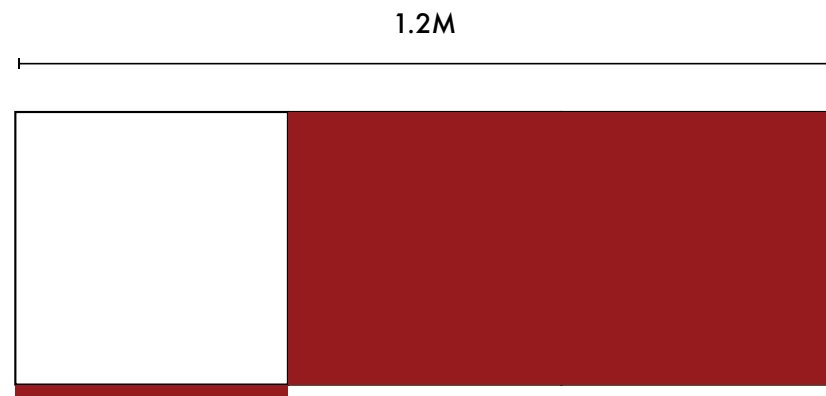

1

MODULAR DISPLAY
SCALE 1/10

**ROBERT
CHARLES
REULAND JR.**

DOCUMENT USAGE

These drawings were made to fulfill partial requirements for the Thesis Capstone of the FIT Masters Program in the Exhibition and Experience Design by Robert Charles Reuland Jr.



SITE

The Ruins of Santa Maria del Piano
02030 Pozzaglia Sabino RI, Italy

CLIENT

The Italian Ministry of Culture
Via del Collegio Romano 27, in central Rome)

KEY PLAN



DRAFTED BY	Robert Reuland
DATE	Dec 9, 2024
SCALE	1/10

WAY FINDING HUB

DRAWING NUMBER
EX.03.15

.4M

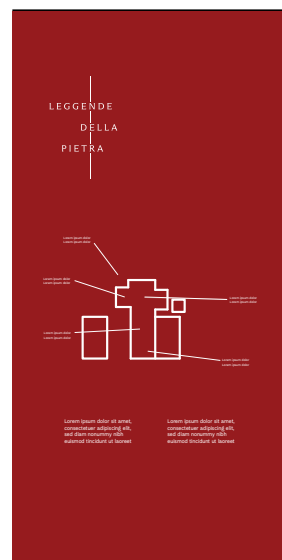
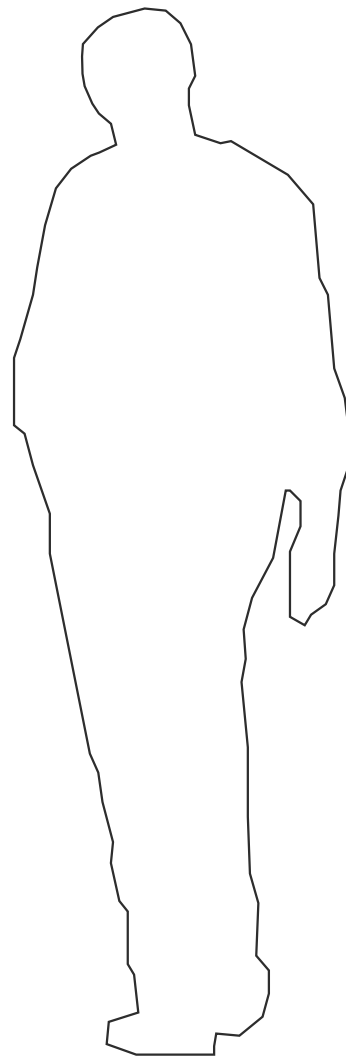
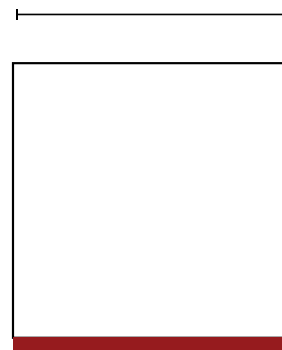

XW.03

.4M

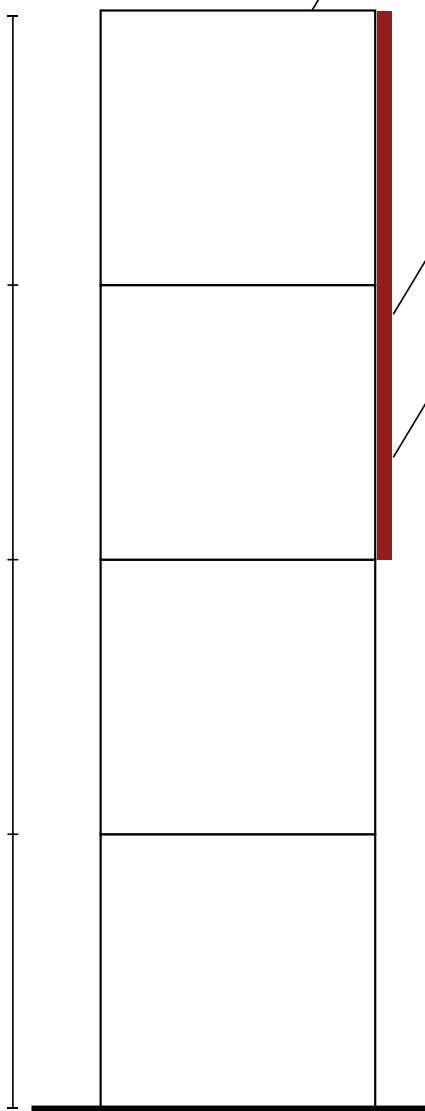

XW.01

XP.01

.4M

.4M

.4M

1 WAY-FINDING STAND
SCALE 1/10



EXHIBITION DETAILING

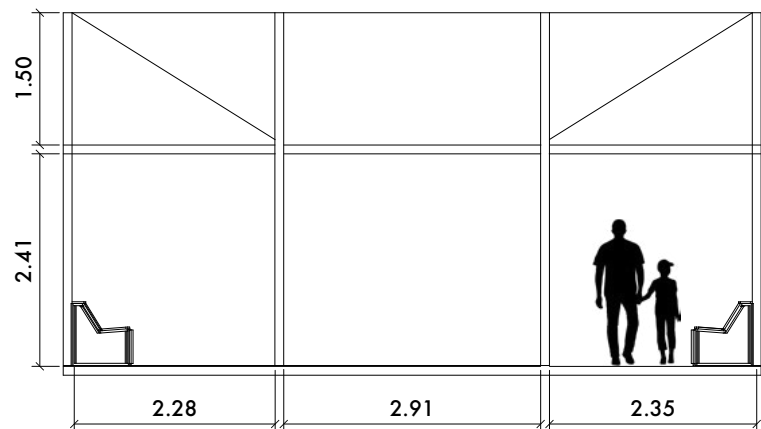
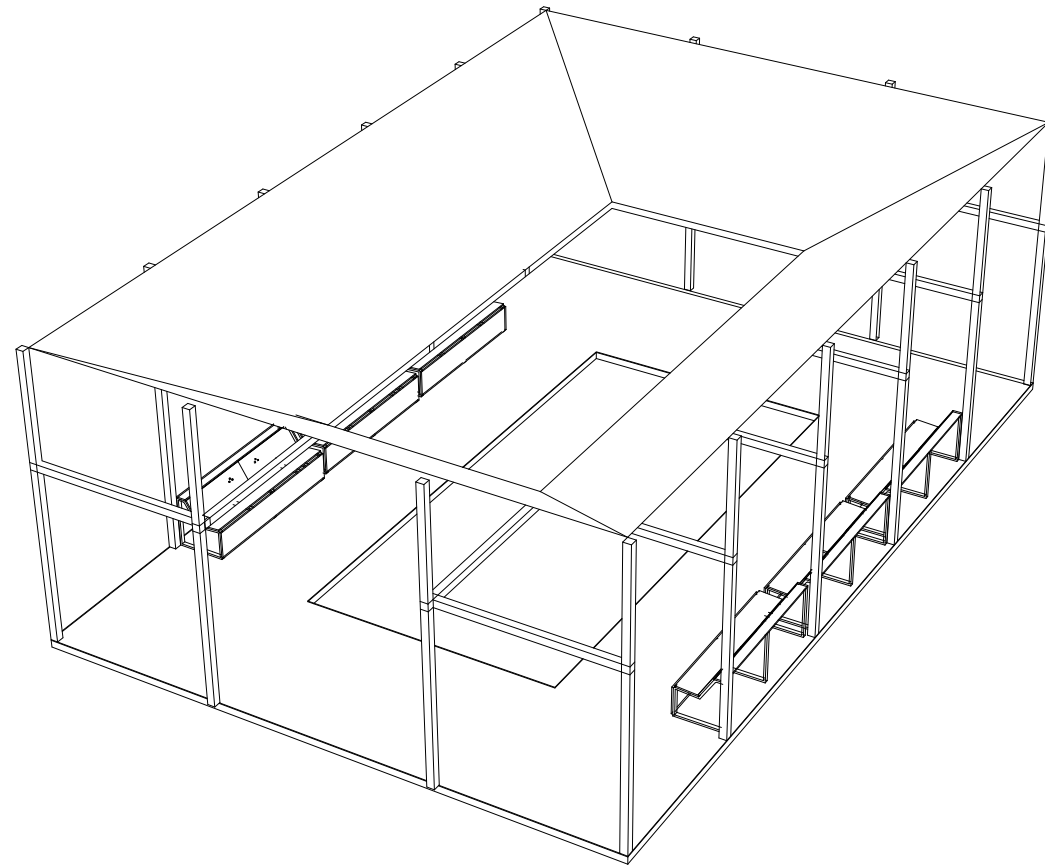
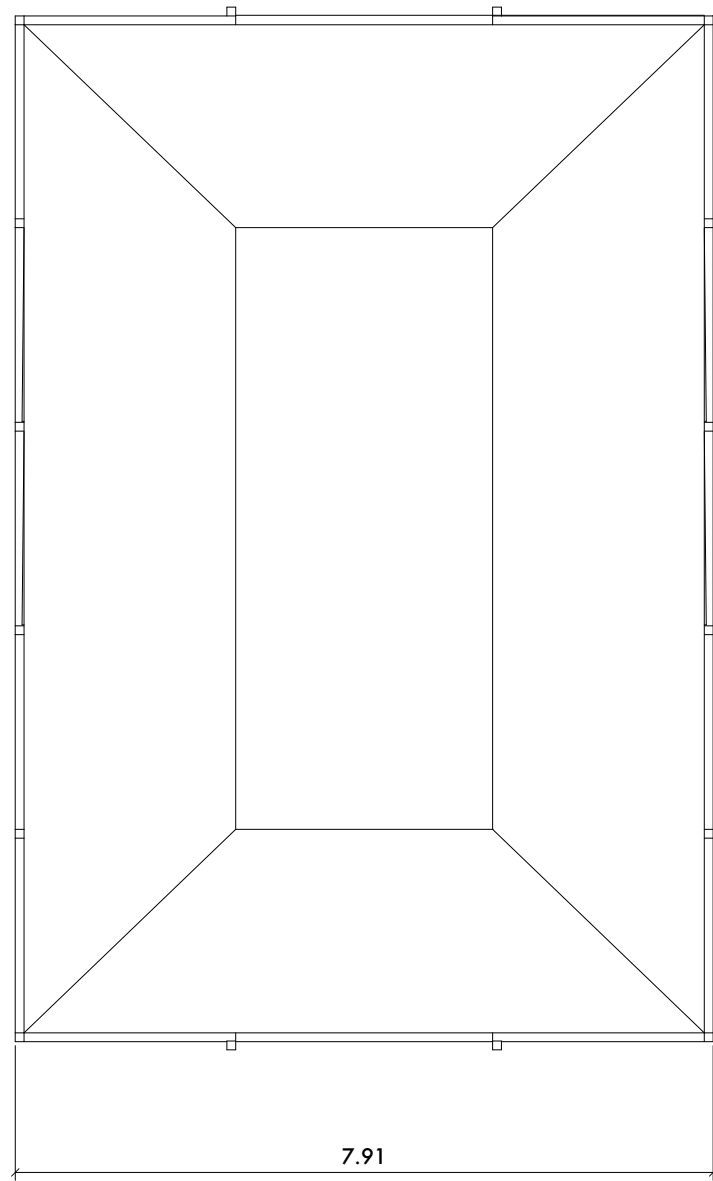

**ROBERT
CHARLES
REULAND JR.**

DOCUMENT USAGE

These drawings were made to fulfill partial requirements for the Thesis Capstone of the FIT Masters Program in the Exhibition and Experience Design by Robert Charles Reuland Jr.

LEGGENDE
DELLA
PIETRA

SITE

The Ruins of Santa Maria del Piano
02030 Pozzaglia Sabino RI, Italy

CLIENT

The Italian Ministry of Culture
Via del Collegio Romano 27, in central Rome)

KEY PLAN

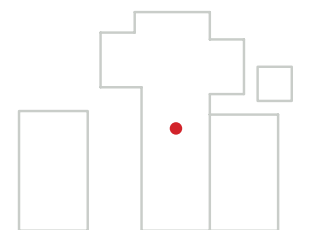

DRAFTED BY Robert Reuland

DATE Dec 9, 2024

SCALE N/A

FRAME 1

DRAWING NUMBER

EX.04.01

1 FRAME STRUCTURE 1
SCALE 1/100

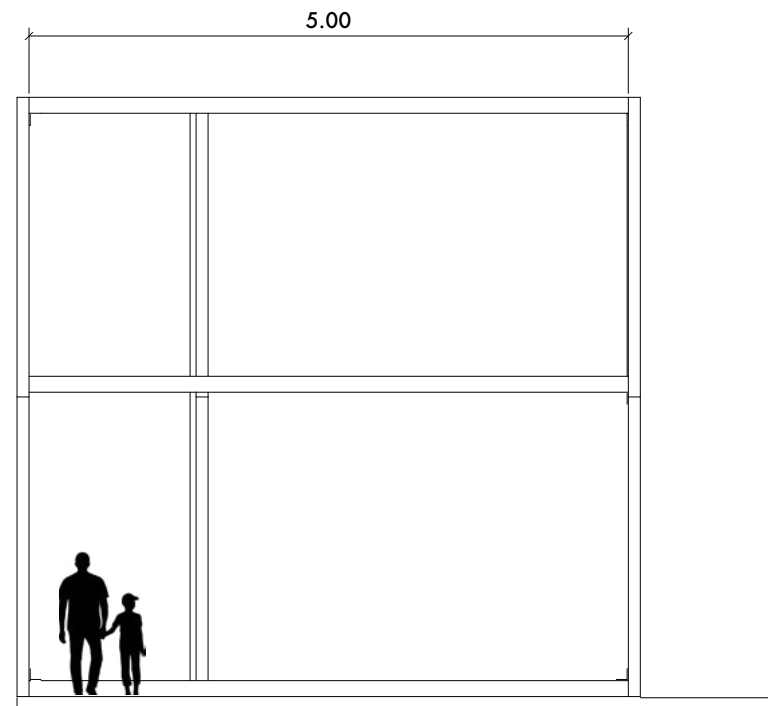
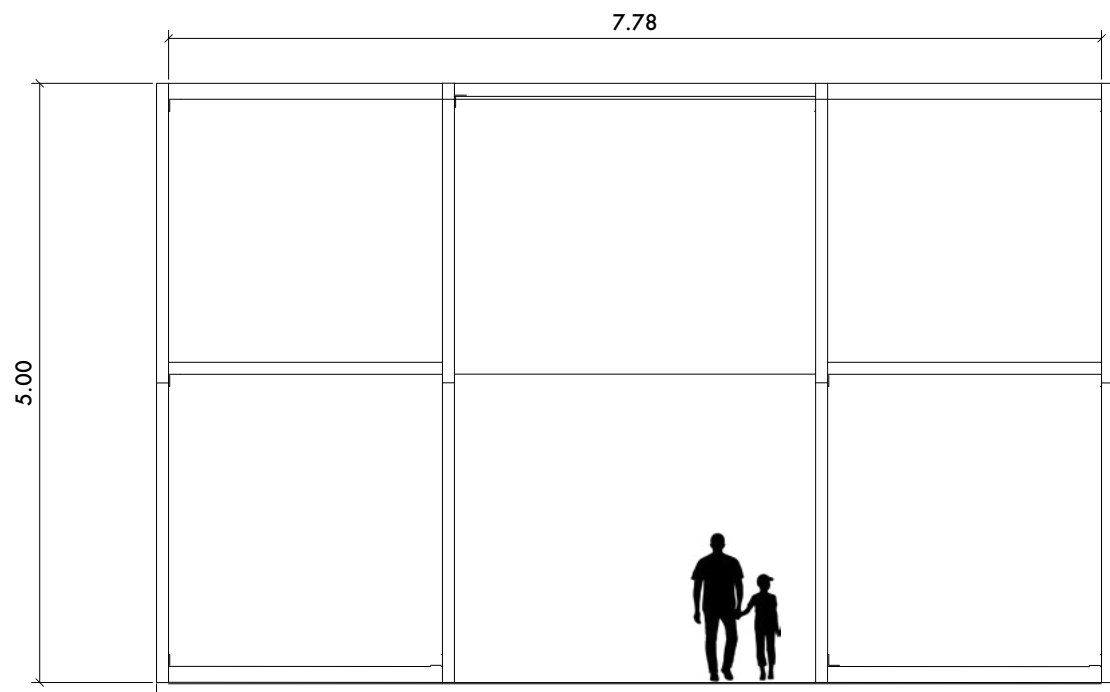
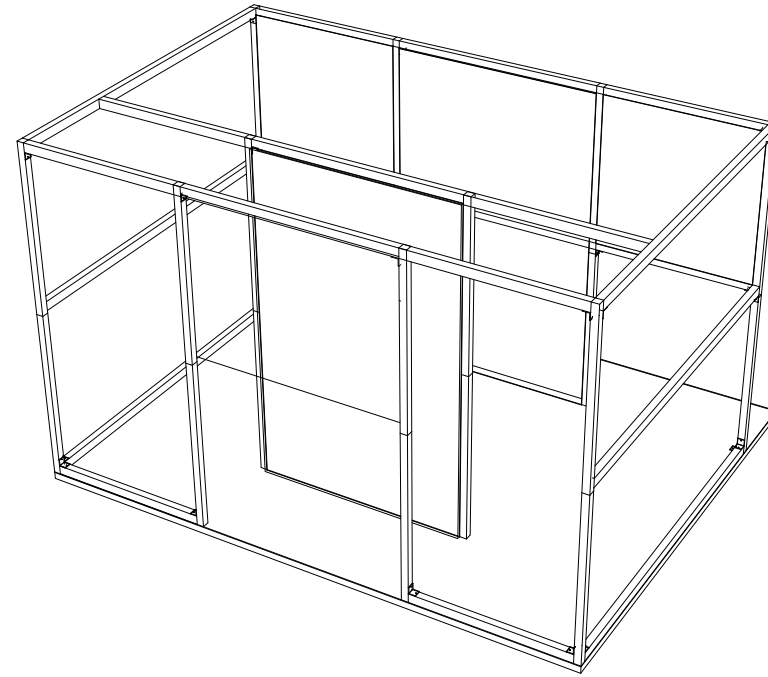
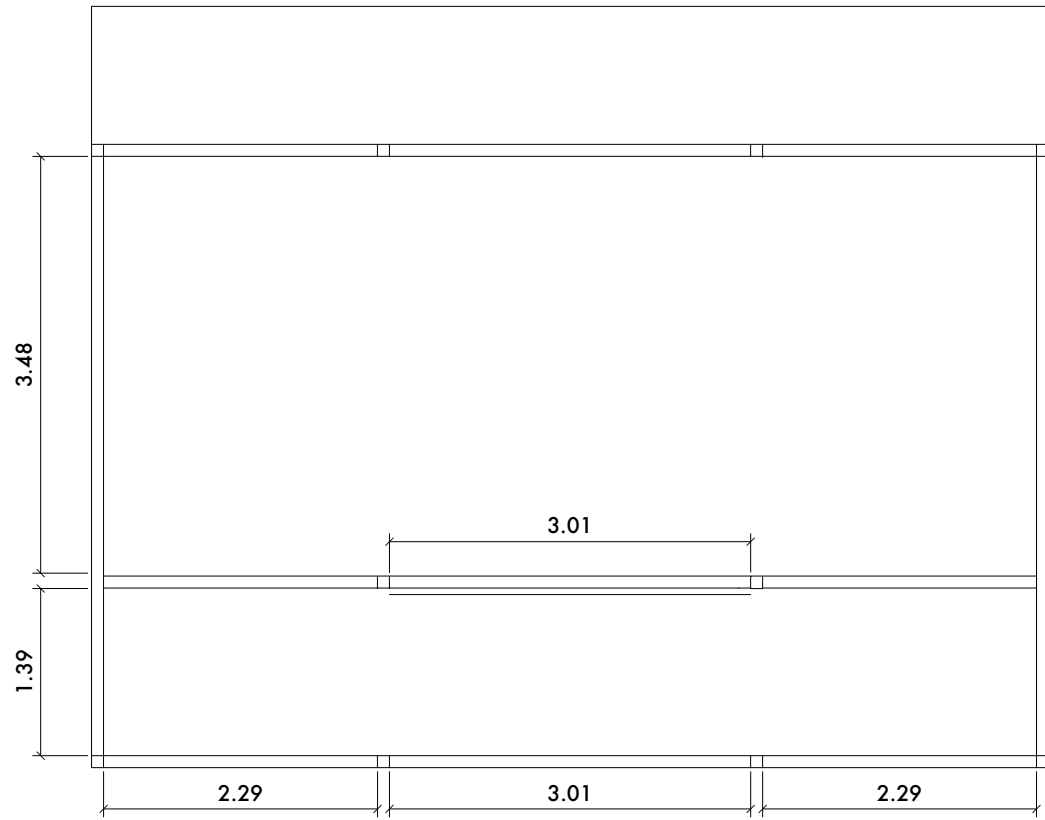

**ROBERT
CHARLES
REULAND JR.**

DOCUMENT USAGE

These drawings were made to fulfill partial requirements for the Thesis Capstone of the FIT Masters Program in the Exhibition and Experience Design by Robert Charles Reuland Jr.

LEGGENDE
DELLA
PIETRA

SITE

The Ruins of Santa Maria del Piano
02030 Pozzaglia Sabino RI, Italy

CLIENT

The Italian Ministry of Culture
Via del Collegio Romano 27, in central Rome)

KEY PLAN

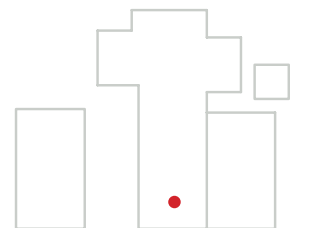

DRAFTED BY Robert Reuland

DATE Dec 9, 2024

SCALE N/A

INTRO AREA FRAME

DRAWING NUMBER

EX.04.02

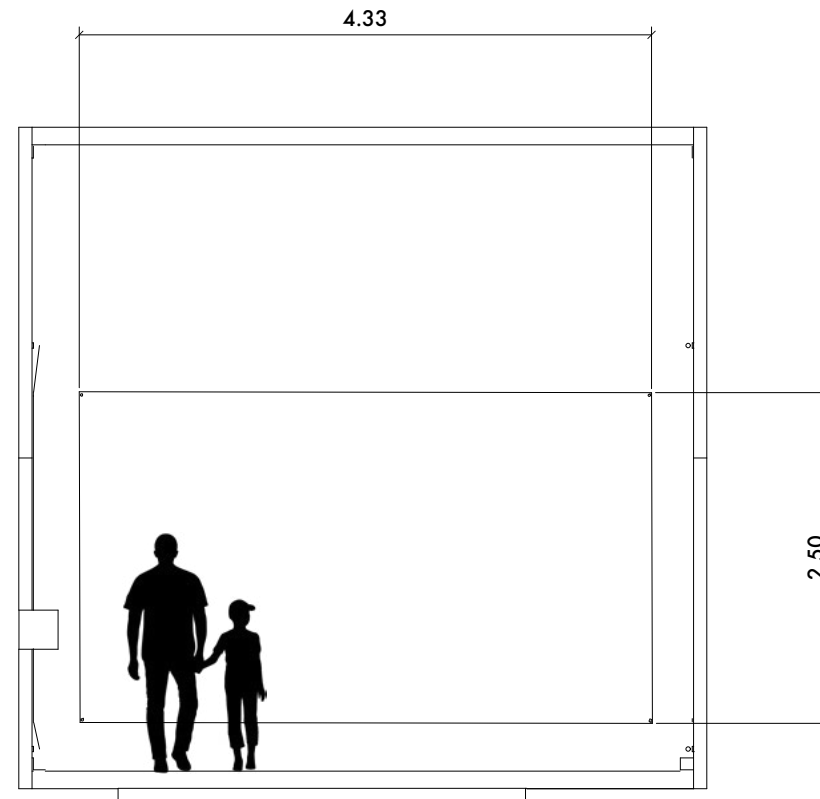
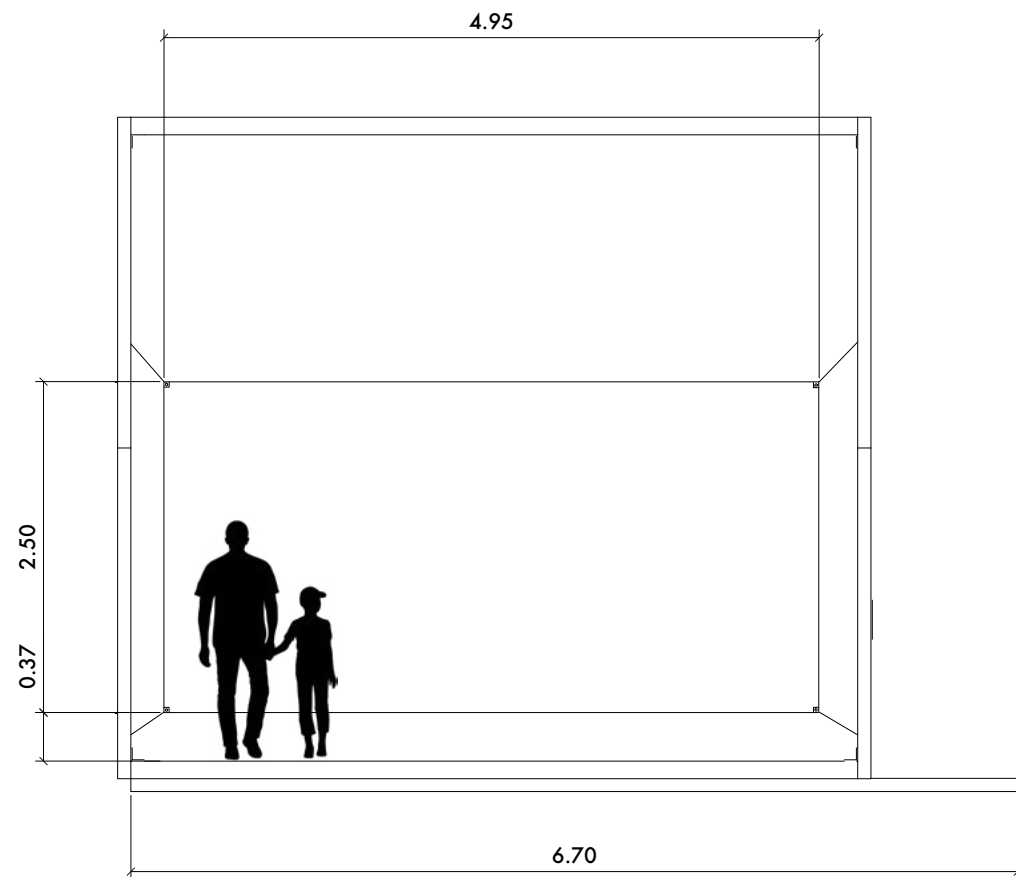
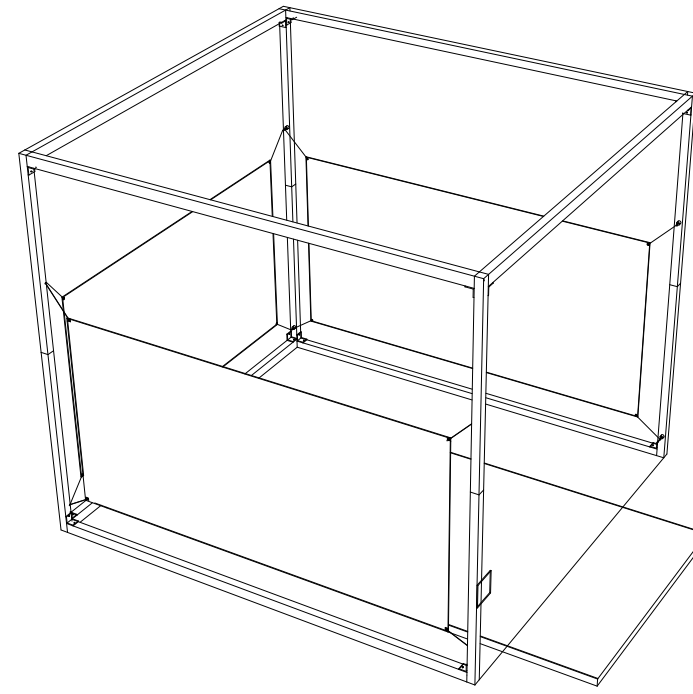
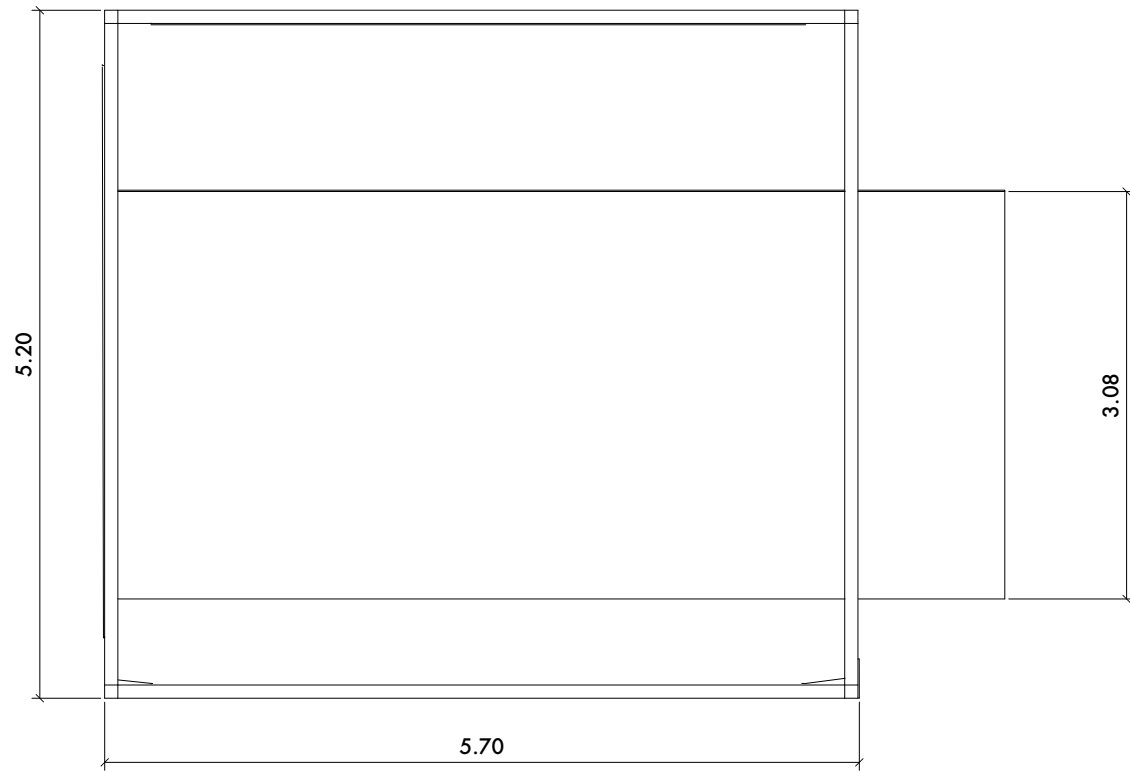

ROBERT CHARLES REULAND JR.

DOCUMENT USAGE

These drawings were made to fulfill partial requirements for the Thesis Capstone of the FIT Masters Program in the Exhibition and Experience Design by Robert Charles Reuland Jr.

LEGGENDE
DELLA
PIETRA

SITE

The Ruins of Santa Maria del Piano
02030 Pozzaglia Sabino RI, Italy

CLIENT

The Italian Ministry of Culture
Via del Collegio Romano 27, in central Rome)

KEY PLAN

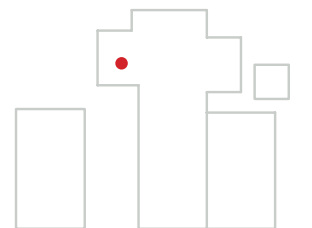

DRAFTED BY Robert Reuland

DATE Dec 9, 2024

SCALE N/A

FRAME 3

DRAWING NUMBER

EX.04.03

1

FRAME STRUCTURE 3

SCALE 1/60

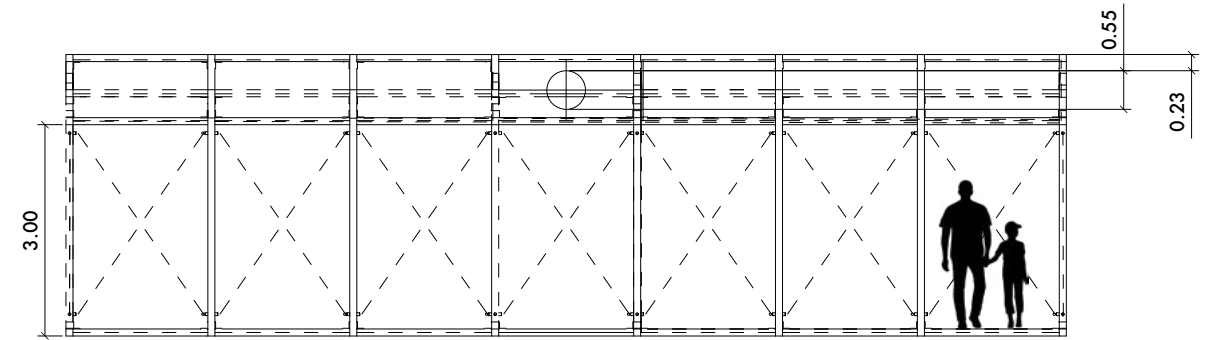
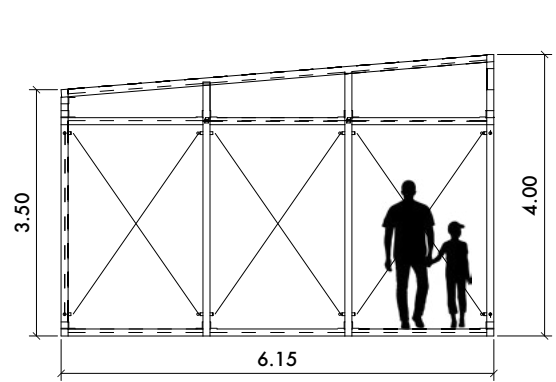
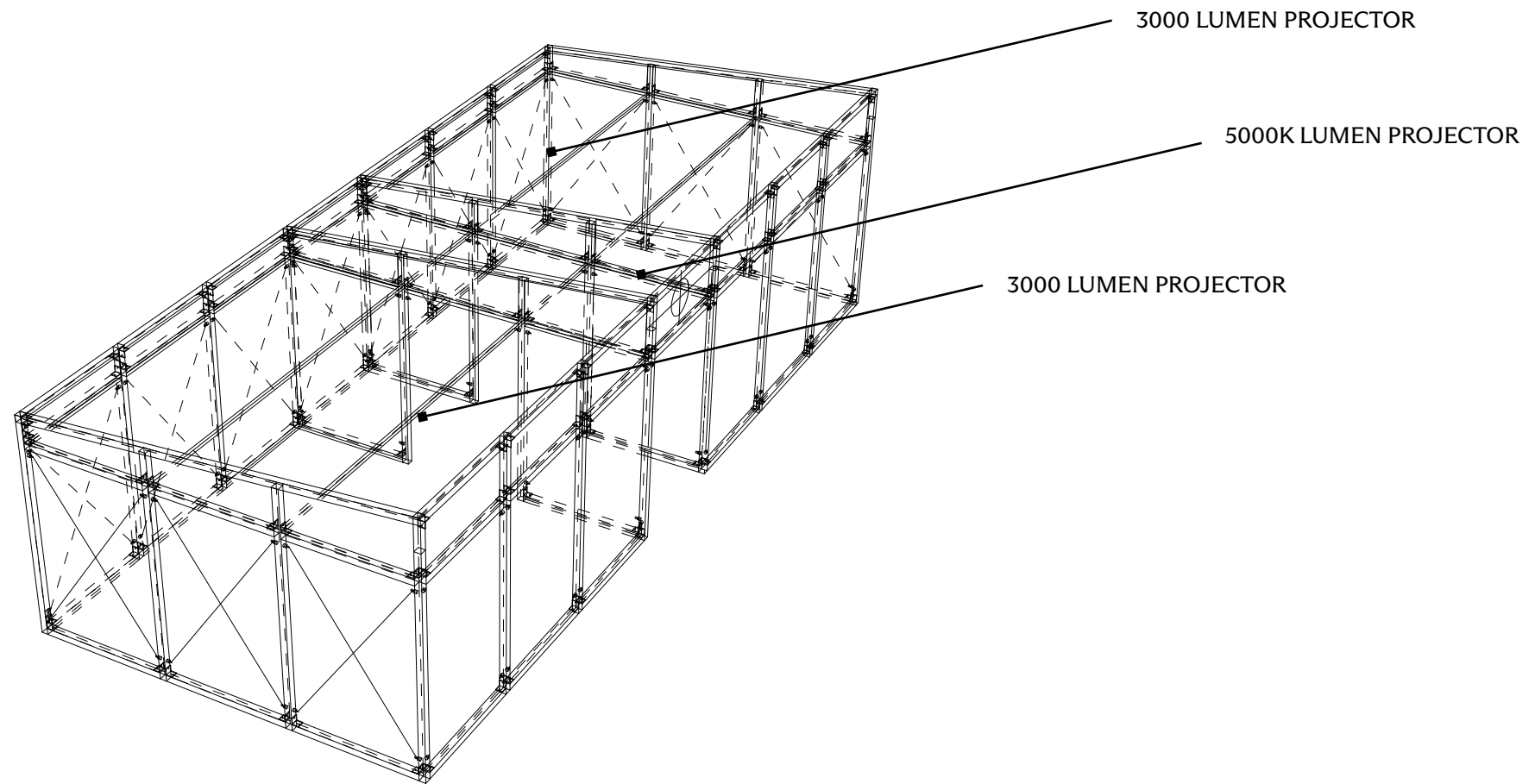
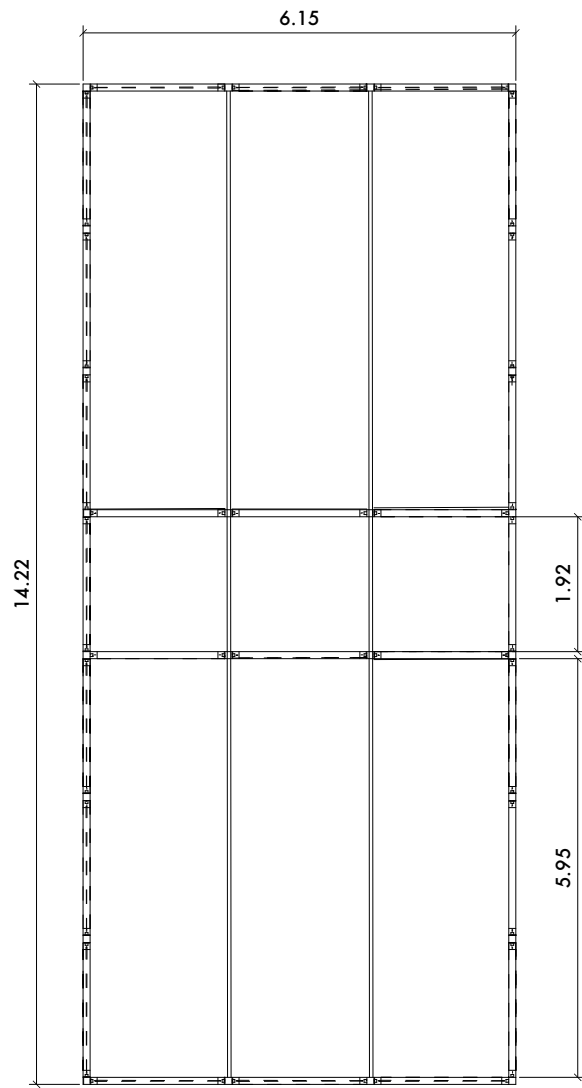

ROBERT CHARLES REULAND JR.

DOCUMENT USAGE

These drawings were made to fulfill partial requirements for the Thesis Capstone of the FIT Masters Program in the Exhibition and Experience Design by Robert Charles Reuland Jr.

LEGGENDE
DELLA
PIETRA

SITE

The Ruins of Santa Maria del Piano
02030 Pozzaglia Sabino RI, Italy

CLIENT

The Italian Ministry of Culture
Via del Collegio Romano 27, in central Rome)

KEY PLAN

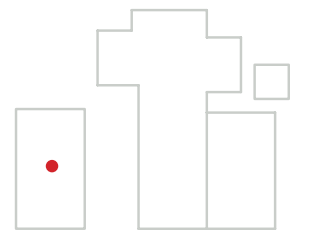

DRAFTED BY Robert Reuland
DATE Dec 9, 2024
SCALE N/A

TENT STRUCTURE

DRAWING NUMBER
EX.04.04

**ROBERT
CHARLES
REULAND JR.**

DOCUMENT USAGE

These drawings were made to fulfill partial requirements for the Thesis Capstone of the FIT Masters Program in the Exhibition and Experience Design by Robert Charles Reuland Jr.

LEGGENDE
DELLA
PIETRA

SITE

The Ruins of Santa Maria del Piano
02030 Pozzaglia Sabino RI, Italy

CLIENT

The Italian Ministry of Culture
Via del Collegio Romano 27, in central Rome)

KEY PLAN

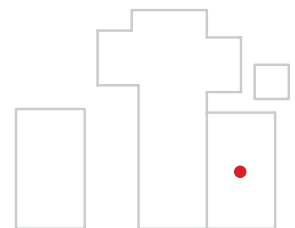

DRAFTED BY Robert Reuland

DATE Dec 9, 2024

SCALE 1/40

ROCK DISPLAY

DRAWING NUMBER

EX.04.05

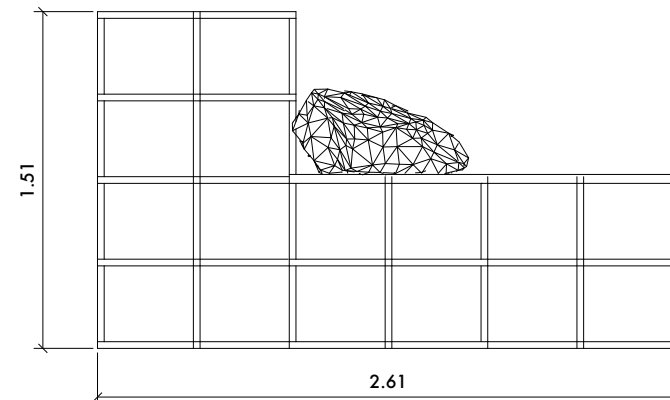
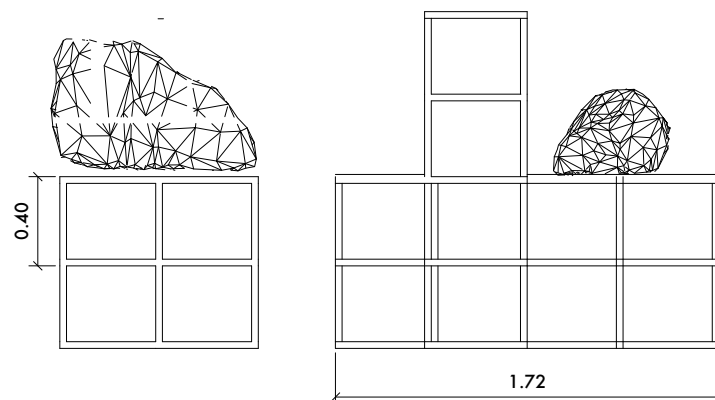
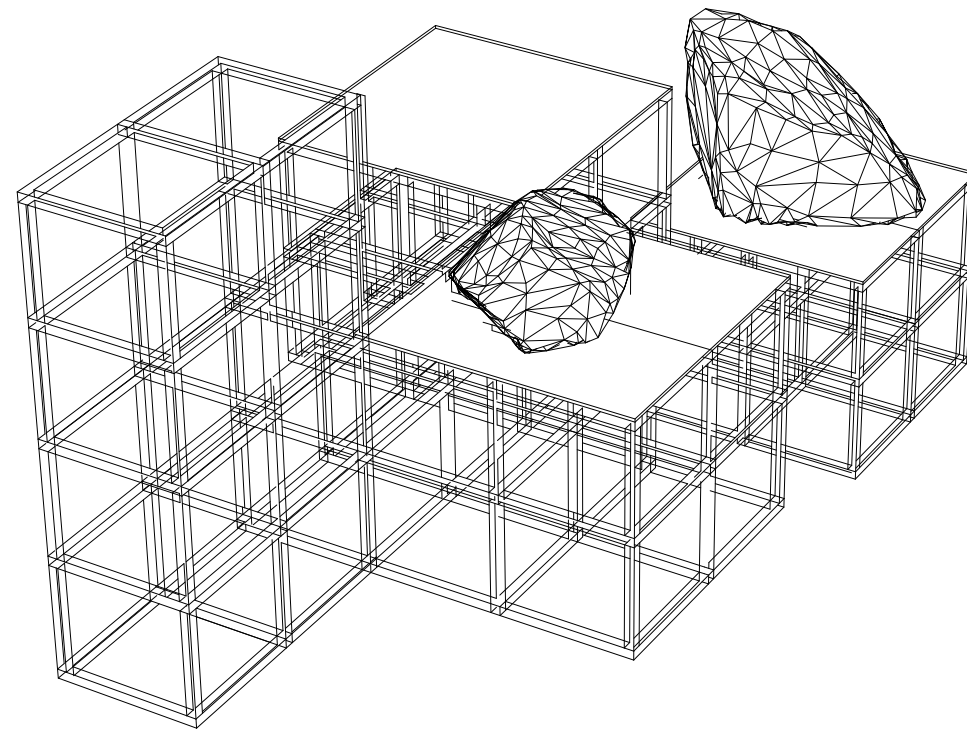
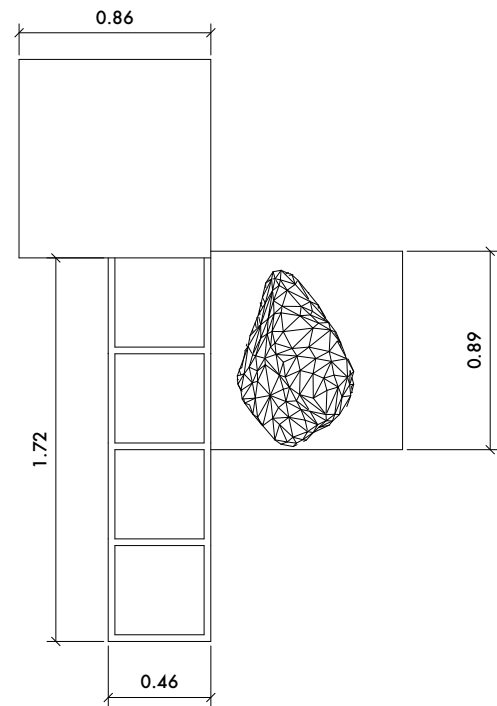
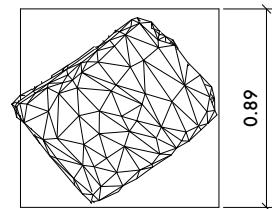

1

ROCK DISPLAY
SCALE 1/40